



JABSCO®

Impeller Removal Tool

- Simple to use
- Fits ALL makes of impeller
- Avoids damage to pump
- All Stainless Steel



50070-0080 ■ 40 - 57mm (1⁹/₁₆" - 2¹/₄")
(compact version)

50070-0040 ■ 40 - 65mm (1⁹/₁₆" - 2⁹/₁₆")

50070-0200 ■ 65 - 118mm (2⁹/₁₆" - 4⁵/₈")



JABSCO®

Impeller Removal Tool

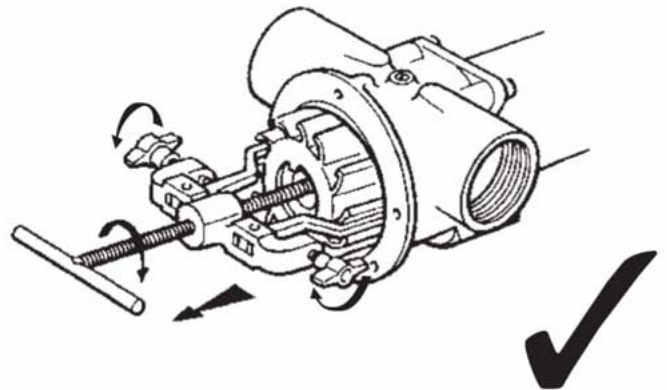
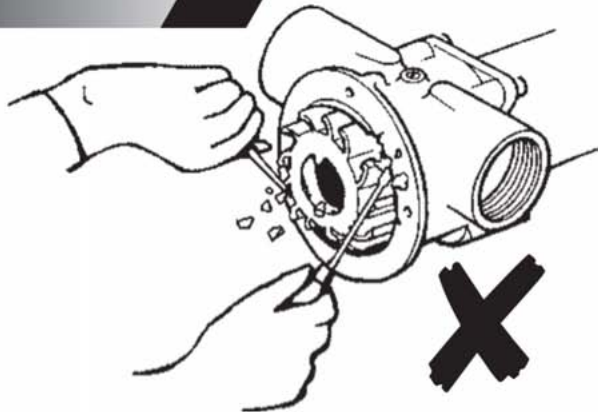

GB Impeller Removal Tool

● Simple to use ● Fits ALL makes ● Avoids damage to pump ● All Stainless Steel

- Remove screws, end cover and gasket from the pump body.
- Extract the impeller from the pump body using the Jabsco Removal Tool.
- Remove any debris from pump chamber and inlet / outlet ports.

FR Outil d'extraction de la turbine

● Facile à utiliser ● Compatible pour TOUTES les marques ● Evite l'endommagement de la pompe ● Fabrication intégrale en acier inoxydable

- Enlever les vis, le couvercle et le joint du corps de la pompe.
- Extraire la turbine du corps de la pompe au moyen de l'outil d'extraction Jabsco.
- Enlever les débris éventuellement présents dans la chambre de la pompe et les orifices d'entrée / sortie.

DE Abziehwerkzeug für Impeller

● Leichte Handhabung ● Für ALLE Fabrikate geeignet ● Verhindert Beschädigung am Pumpengehäuse ● Aus rostfreiem Stahl hergestellt

- Deckelschrauben lösen, Enddeckel und Deckeldichtung vom Pumpengehäuse abnehmen.
- Impeller mit Jabsco-Abziehwerkzeug aus dem Pumpengehäuse herausziehen.
- Pumpengehäuse und Öffnungen für Zu- und Ablauf reinigen

IT Estrattore per giranti

● Di facile uso ● Adatto a TUTTE le marche ● Evita danni alla pompa ● Tutto acciaio inossidabile

- Togliere le viti, il coperchio e la guarnizione dal corpo della pompa.
- Togliere la girante dal corpo pompa usando l'estrattore Jabsco.
- Eliminare ogni detrito dalla camera della pompa e dagli ingressi/uscite.

NL Waaier uitbouwgereedschap

● Eenvoudig in gebruik ● Past op ALLE merken ● Voorkomt beschadiging van de pomp ● Geheel uit RVS

- Schroeven, einddeksel en pakking van pomplichaam afnemen.
- Waaier met behulp van uitbouwgereedschap uitnemen.
- Eventueel gruis enz. uit pompkamer en inlaat/uitlaat poorten verwijderen.

SE Demonteringsverktyg för impellrar

● Enkelt att använda ● Passar ALLA fabrikat ● Skadar inte pumpen ● Helt i rostfritt stål

- Lossa skruvar, lock och pakning från pumphuset.
- Drag ut impellern ur huset med hjälp av Jabsco demonteringsverktyg.
- Tag bortev skräp ur pumphuset och inlopps/utloppsportar.

ES Herramienta para extraer Impulsores

● Fácil de utilizar ● Apta para TODAS las marcas ● Evita el daño a la bomba ● Totalmente de acero inoxidable

- Remover los tornillos, la tapa del cabezal de la bomba y su junta.
- Remover el impulsor del cuerpo de la bomba utilizando el extractor de impulsores.
- Retire cualquier escombros presente en la cámara de la bomba y/o en sus conexiones de entrada y salida

PT Ferramenta para Remoção do Impulsor

● Utilização simples ● Adapta-se a TODAS as marcas ● Evita danificar a bomba ● Fabricada inteiramente em aço inoxidável

- Retire os parafusos, a tampa traseira e a junta da parte principal da bomba.
- Para retirar o impulsor da bomba, utilize a ferramenta de remoção do impulsor.
- Remova quaisquer resíduos do compartimento da bomba e dos orifícios de entrada/saída.

DK Afmonteringsværktøj for impeller

● Let at anvende ● Passer til ALLE fabrikater ● Undgår beskadigelse af pumpen ● Helt i rustfrit stål

- Fjern skruer, endedeksel og pakning fra pumpehuset.
- Fjern impeller fra pumpehuset med Jabsco afmonteringsværktøjet.
- Fjern evt. snavs fra pumpekammeret og tilgangs/afgangsporte.

FI Työkalu juoksupyörän poistamiseksi

● Helppokäyttöinen ● Sopii KAIKKIIN malleihin ● Ei vahingoita tumbua ● Aisi teräksestä

- Poista ruuvit, takakansi ja tiiviste pumpun rungosta.
- Vedä juoksupyörä ulos pumpun rungosta Jabsco -poistotyökalun avulla.
- Poista kaikki roskat pumpun pesästä sekä sisäänmeno- ja ulostuloaukoista.

GR Εργαλείο αφαίρεσης στροφέιου

● Εύχρηστο ● Κατάλληλο για μοντέλα ΟΛΩΝ των κατασκευαστών ● Εμποδίζει τυχόν ζημιά στην αντλία ● Όλο από ανοξείδωτο χάλυβα

- Βγάλε τις βίδες, το κάλυμμα άκρης και τη φλάντζα από το σώμα της αντλίας.
- Βγάλε το στροφέιο από το σώμα της αντλίας χρησιμοποιώντας εργαλείο αφαίρεσης Jabsco
- Αφαιρέστε τυχόν ακαθαρσίες από το θάλαμο της αντλίας και τις θύρες εισόδου-εξόδου.

TR Lastik Impeller Sökme Aleti

● Kullanımı kolay ● TÜM markalara uyar ● Pompaya zarar vermez ● Tamamen Paslanmaz Çelikten

- Vidaları, kapağı ve contaı pompanın gövdesinden sökün.
- Jabsco Sökme Aletini kullanarak impelleri pompanın gövdesinden çıkarın.
- Pompa silindiri içinde ve giriş/çıkış deliklerinde döküntü varsa temizleyin.

JP インペラ (羽根車) 取り外し用具

● 使いかた簡単 ● 全メーカー製品に対応 ● ポンプ損傷を防ぐ ● ステンレススチール製

- ポンプ本体から、ネジ、エンドカバー、ガスケットを取り外します。
- ジャブスコ取り外し用具を使って、ポンプからインペラを取り外します。
- ポンプ室およびインレット/アウトレット・ポートからゴミや異物を除去します。

Jabsco

Jabsco, 1 Kondelin Road, Cape Ann Industrial Park, Gloucester, MA 01930
Tel: +1 978 281 0440 Fax: +1 978 283 2619

USA

Jabsco, Bingley Road, Hoddesdon, Hertfordshire EN11 0BU
Tel: +44 (0) 1992 450 145 Fax: +44 (0) 1992 467 132

UK

Fluid Products Canada, 55 Royal Road, Guelph, Ontario N1H 1T1
Tel: +1 519 821 1900 Fax: +1 519 821 2569

CANADA

NHK Jabsco Co Ltd, 3-21-10, Shin-Yokohama, Kohoku-ku, Yokohama 222
Tel: +81 (0) 45 475 8906 Fax: +81 (0) 45 475 8908

JAPAN

Jabsco GmbH, Oststraße 28, 22844 Norderstedt
Tel: +49 (0) 40 53 53 73 0 Fax: +49 (0) 40 53 53 73 11

GERMANY

Jabsco Marine Italia S.r.l., Via Tommaseo, 6, 20059 Vimercate, Milano
Tel: +39 039 6852323 Fax: +39 039 666307

ITALY

Warranty: All products of the company are sold and all services of the company are offered subject to the company's warranty and terms and conditions of sale, copies of which will be furnished upon request

© Copyright 2003

Discover Jabsco at www.jabsco.com

PM000-0015 Rev 10/03