

Technic **31150**

EN **Operating manual**

TRUMPF 95





Scan the following QR code or click the icon in the PDF to access the TRUMPF 95 product page. There you will find further product information such as videos and application examples.



Scan the following QR code or click the preceding icon in the PDF view to access the TRUMPF 95 assembly video.
The video is provided as a supplement and does not replace reading this operating manual.



Imprint

This operating manual was created by:
Gerriets GmbH
Im Kirchengürtle 5-7
DE-79224 Umkirch
+49 7665 960 0
gerriets.com

Document number and date: BA_EN_311500000_20260428

Copyright notice: ©2025 Gerriets GmbH

The content of this operating manual is protected by copyright. Any type of modification or utilisation that goes beyond the limits of copyright law requires the express written permission of Gerriets GmbH. Gerriets GmbH accepts no responsibility for damage resulting from unauthorised changes.

Note on the original version and translations:

The original operating manual was created in German.

All other language versions are translations of the original operating manual.

Subject to errors and technical modifications.

Table of contents

1 ABOUT THIS DOCUMENT	1.1 HOW TO USE THE OPERATING MANUAL	6
	1.1.1 Symbols and labelling	6
2 STRUCTURE AND FUNCTION	2.1 OVERVIEW – WALK-ALONG TRACK	8
	2.2 OVERVIEW – SIDE CORD OPERATION	10
	2.3 OVERVIEW – TOP CORD OPERATION	12
	2.4 OVERVIEW – DOUBLE TOP CORD OPERATION	14
	2.5 TRACK SWITCH	16
	2.5.1 Manual track switch	16
	2.5.2 Motor driven track switch with switch control	17
	2.5.3 Track switch positions	18
	2.6 SUSPENSION VARIANTS	20
	2.7 MASTER AND SPECIAL RUNNERS – WALK-ALONG TRACK	22
	2.8 MASTER AND SCENERY RUNNERS – SIDE CORD OPERATION	24
	2.9 MASTER AND SCENERY RUNNERS – TOP CORD OPERATION	25
	2.10 MASTER AND SCENERY RUNNERS – DOUBLE TOP CORD OPERATION	26
	2.11 ACCESSORIES AND SPARE PARTS	27
	2.12 MANUAL DRIVE – ROPE-DRIVE	29
	2.13 MANUAL DRIVE – HAND-DRIVE	30
	2.14 MANUAL DRIVE – FLOOR PULLEYS	31
3 TECHNICAL DATA	3.1 AMBIENT CONDITIONS	32
	3.2 TRACK SYSTEM	32
	3.2.1 Permissible load with standard slot nut	32
	3.2.2 Permissible load with slide-in slot nut	33
	3.2.3 Permissible load with heavy-duty (HD) slot nut	33
	3.3 RUNNERS AND MASTER RUNNERS	34
	3.4 TRACK SWITCH	36
	3.4.1 Mechanical data	36
	3.4.2 Electrical data	37
	3.4.3 G-FRAME 54 track switch control unit	38
4 TRANSPORT	4.1 TRANSPORT	39
5 ASSEMBLY	5.1 MOUNTING INSTRUCTIONS / TRACK SYSTEM	41
	5.2 INSTALLING THE TRACK SYSTEM	42
	5.2.1 Track splice	42
	5.2.2 Double track suspension bracket (2-track)	46
	5.2.3 End stop HD	48
	5.2.4 TRUMPF 95 end stop	49
	5.3 INSTALLING SUSPENSIONS	50

	5.3.1	Central mounting G-TWIST II – Ceiling mounting / walk-along track	50
	5.3.2	Hook clamp G-CLAMP direct – Walk-along track	53
	5.3.3	Ceiling suspension – Ceiling mounting	56
	5.3.4	Hook clamp G-CLAMP – Cord operation	58
	5.3.5	Wall mount bracket direct – Walk-along track	61
	5.3.6	Wall mount bracket – Cord operation	63
	5.4	INSTALLING THE CORD OPERATION SYSTEM	65
	5.4.1	Side cord operation	65
	5.4.2	Top cord operation	72
	5.4.3	Double top cord operation	82
	5.5	INSTALLING MANUAL ROPE DRIVES	88
	5.5.1	HAND-DRIVE	88
	5.5.2	ROPE-DRIVE	90
	5.5.3	Traction cord installation on double-groove traction disc	97
	5.5.4	Floor pulley (polyester cord)	99
	5.5.5	Hemp rope pulley for weighting sandbag	100
	5.5.6	Stirrup floor pulley with foot stirrup	100
	5.5.7	Self-tensioning floor pulley with counterweight	101
	5.6	INSTALLING THE TRACK SWITCH	103
	5.6.1	Ceiling mounting (manual/electrical)	103
	5.6.2	Electrical connection	107
<hr/>			
6	OPERATION		
	6.1	HAND-DRIVE	108
	6.2	ROPE-DRIVE	110
	6.3	TRACK SWITCH	111
	6.3.1	Manual operation	111
	6.3.2	Electric operation	111
<hr/>			
7	MAINTENANCE AND SERVICING		
	7.1	PROPER MAINTENANCE	112
	7.2	MAINTENANCE SCHEDULE	112
	7.3	STORAGE	113
<hr/>			
8	TROUBLESHOOTING		
	8.1	FUNDAMENTALS	114
<hr/>			
9	DECOMMISSIONING AND DISPOSAL		
	9.1	TEMPORARY SHUTDOWN	115
	9.2	ENVIRONMENTAL PROTECTION, DISMANTLING, AND DISPOSAL	115
<hr/>			
10	SAFETY		
	10.1	UTILISATION	116
	10.1.1	Intended use	116
	10.1.2	Foreseeable misuse	116
	10.2	GENERAL WARNINGS	117
	10.3	PERSONNEL AND TARGET GROUP	118

	10.3.1	Responsibility of the operator	118
	10.3.2	Responsibility of the staff	118
	10.3.3	Personal protective equipment	118
	10.4	GUIDELINES AND STANDARDS	119
	10.5	DISCLAIMER	119
<hr/>			
11	ABBREVIATIONS AND EXPLANATION	11.1	TERMS AND EXPLANATION 120
<hr/>			
12	APPENDIX	12.1	SCREW TIGHTENING TORQUES 121
<hr/>			
13	CONTACT AND WARRANTY	13.1	CONTACT US 122
		13.2	CUSTOMER SERVICE AND REPAIR 123
<hr/>			

1 About this document

1.1 How to use the operating manual

Basic information on the operating manual



This operating manual is part of the TRUMPF 95 track system, including:

- TRUMPF 95 track system – Item no. 31150 0XXXX and all component parts for manual operation
- Track switches (manual or electrical with control unit) Item no. 31150 011XX
- Accessories (see *chapter 2.11 Accessories and spare parts* [► p. 27]).

This manual contains important safety and usage instructions for the product.

- ➔ Read the operating manual thoroughly before use, especially the *chapter 10 Safety* [► p. 116].
- ➔ If you have any questions, please contact Gerriets GmbH (for contact details see *chapter 13.1 Contact us* [► p. 122]).
- ➔ Ensure that all personnel working with the track system have access to this manual.
- ➔ Keep the operating manual available in the immediate vicinity of the described product at all times.
- ➔ Hand over the operating manual to the new owner when selling the product.

Safety information

In *the chapter 10 Safety* [► p. 116] you will find information on the intended use, higher-level safety instructions, information on personnel qualifications, safety and protective equipment, guidelines, and standards as well as the disclaimer.

Specific safety instructions can be found in *chapter 4 Transport* [► p. 39], *chapter 5 Assembly* [► p. 40] and *chapter 7 Maintenance and servicing* [► p. 112].

Accident prevention regulations

- ➔ In addition to the instructions in this operating manual, the local accident prevention regulations and national occupational health and safety regulations apply.

1.1.1 Symbols and labelling

Display of a warning notice

Warnings are labelled with a signal word and pictogram and are highlighted separately. On the left-hand side of the warning, further pictograms may indicate specific dangers (in this example, warning of electrical voltage). Embedded warnings deviate from this scheme.



DANGER

Type and source of danger

Possible consequences if the warning is not observed.

- ➔ Measures to avert the danger and its consequences.

Danger levels of warnings

The signal word, such as warning, describes the hazard level:

**DANGER**

Elevated risk of an imminently hazardous situation resulting in severe injury or death.

**WARNING**

Medium risk of a potentially hazardous situation resulting in severe injury or death.

**CAUTION**

Minimal risk of a potentially hazardous situation resulting in a minor or moderate injury.

**NOTICE**

Risk of a potentially hazardous situation resulting in damage to the product or property of others.

Explanation of warning and mandatory signs used in the operating manual

Warning of specific risks



General warning sign



Warning of suspended loads



Warning of falling objects



Warning of electrical voltage



Warning of obstacles in the head area



General mandatory sign



Follow the operating instructions

Other notes and symbols



Labelling an activity to be conducted (one step)



Labelling of page number references

1.

Labelling the first step



Labelling a direct consequence of an action



Marking the completion of an action



Labelling of enumerations



Labelling of valuable information

2 Structure and function

Track system

Item no. 31150 0XXXX

TRUMPF 95 is a track system for manual or electrical operation of medium to heavy curtains and backdrop materials. It is used in stage and studio applications and includes complex track guides with curves and track switches. The system enables various curtain pull variants, depending on the desired function, shape, and installation situation. These are realised using appropriate attachments: the walk-along track without cord operation, the side cord operation, the top cord operation, and the double top cord operation. The track system is driven both manually but also with motorised drives like FRICTION-DRIVE and TRAC-DRIVE.

➔ For information on the motorised drives, please refer to the other documents relating to your system.

There are various suspension and mounting options, which are shown at *chapter 2.6 Suspension variants* [► p. 20]. These include direct ceiling mounting, on trusses and load bars with hook clamps and on wall mount brackets.

More complex track layouts and parking positions can be realised with track switches.

Curtain runners and master runners are available in various designs with different numbers of castors and support rollers as well as brakes.

2.1 Overview – Walk-along track

Number and designation (1/2): The following illustration shows a single-track walk-along track for a two-part and overlapping curtain. Walk-along tracks are track systems without a rope drive: the moving parts are pulled by hand.

1 TRUMPF 95 end stop
Item no. 31150 00981

2 STUDIO/TRUMPF
4-wheel-runner
Item no. 31000 0004X

3 TRUMPF 95 G-CLAMP 48/60
Item no. 31150 08091

4 STUDIO/TRUMPF G3-Silence
2-wheel runner
Item no. 31000 0003X

5 TRUMPF 95/STUDIO
end stop HD
Item no. 31000 0094X

The TRUMPF 95 track is mounted using the TRUMPF 95 G-CLAMP 48/60 (3/ Fig. 1) and the supplied mounting material, e.g. on a truss. Alternatively, the track can also be mounted using the wall bracket or the ceiling mounting plate G-TWIST II (see also *chapter 2.6 Suspension variants* [► p. 20]).

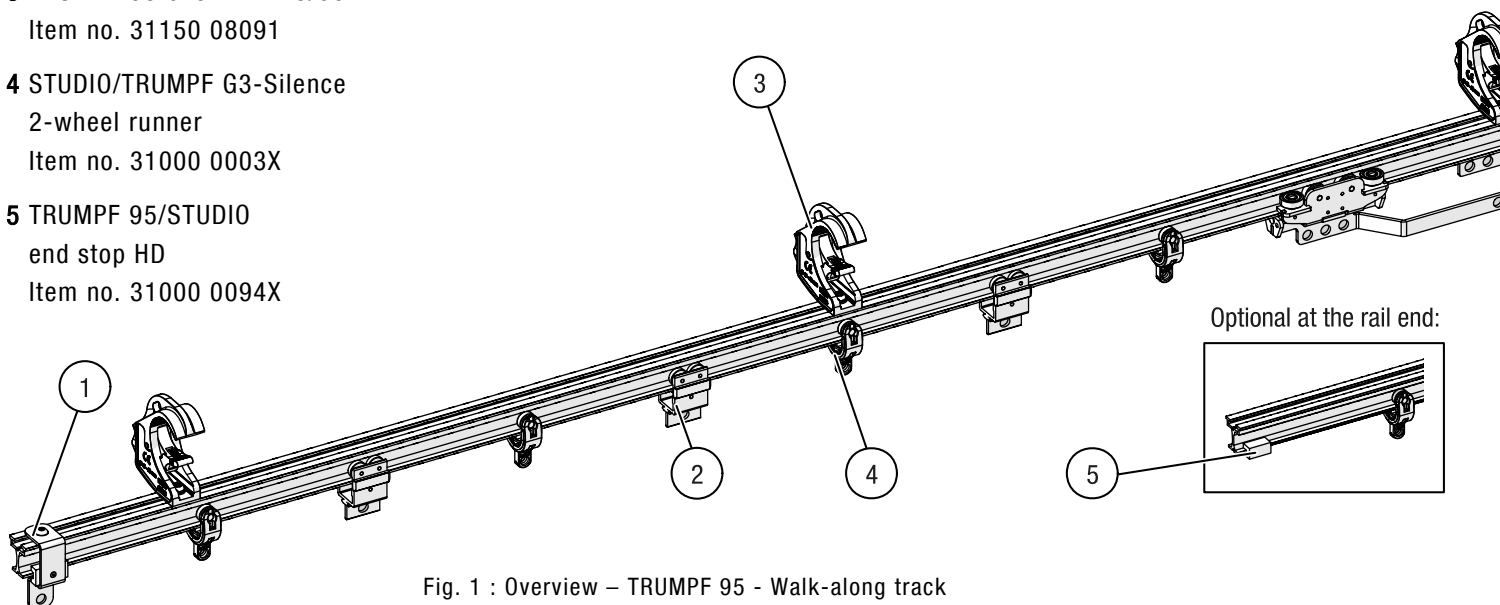
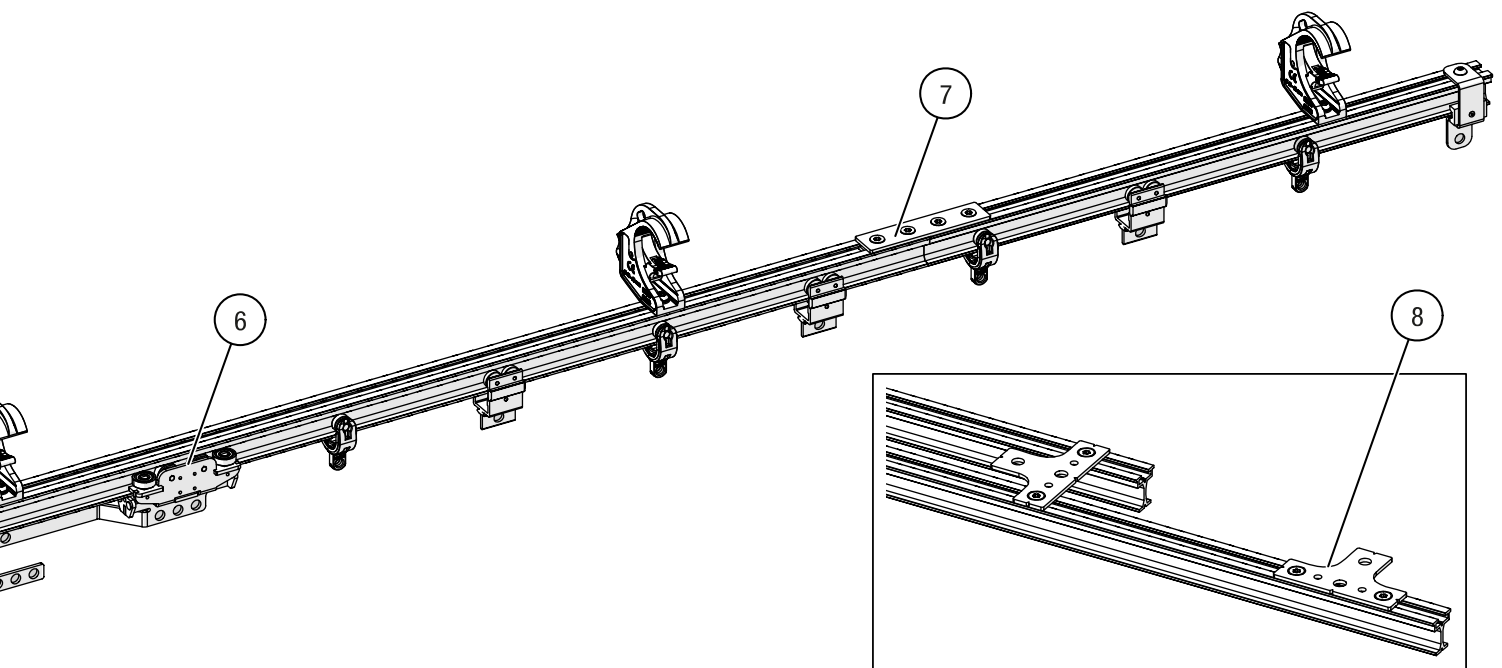

Fig. 1 : Overview – TRUMPF 95 - Walk-along track

- Number and designation (2/2):** The track sections are connected to each other using TRUMPF 95 track splices (7/Fig. 1) and can be connected to form a double track system using the TRUMPF 95 double track suspension bracket (8/Fig. 1).
- 6** STUDIO/TRUMPF 95 master runner HD with overlap arm
Item no. 31000 00061
- 7** TRUMPF 95 track splice
Item no. 31150 00061
- 8** TRUMPF 95 double track suspension bracket
Item no. 31150 08021
- The curtain is mounted on a master runner followed by 2-wheel or 4-wheel runners. The STUDIO/TRUMPF G3-Silence 2-wheel-runner (4/Fig. 1) has a 360° rotatable mount for the curtain in the centre and a side mount for curtain hooks.
- The curtain can also be attached to the STUDIO/TRUMPF 4-wheel runner (2/Fig. 1). The four upper and four lower rollers reduce friction and improve curtain movement, especially on curves.
- Depending on the product purchased, the STUDIO/TRUMPF 95 master runner HD (6/Fig. 1) is fitted with an overlap arm, which can also be used to cover the curtain sections in a single-track system. The curtain sections can be attached to the holes provided in the runner and master runner using various fastening methods, including curtain hooks, ties, soft ties, and shackles.
- The track ends are closed with a TRUMPF 95 end stop (1/Fig. 1) which has the possibility to attach a curtain or the TRUMPF 95/STUDIO end stop HD (5/Fig. 1). The TRUMPF 95/STUDIO end stop with curtain mounting has a central attachment hole to keep the curtain in the parking position.



2.2 Overview – Side cord operation

Number and designation (1/2): The side cord operation is used when a flat and/or narrow installation situation is required. The side cord operation has a lower overall height and is narrower than, for example, the top cord operation. Due to its design, the side cord operation is the easiest to realise of all cord operation types. The side cord operation is only suitable for single-track and straight track systems up to a length of 12 metres.

1 TRUMPF 95 return pulley
Item no. 31150 00831

2 TRUMPF 95 end stop
Item no. 31150 00981

3 TRUMPF 95 side cord track suspension bracket
Item no. 31150 08041

4 TRUMPF 95 side cord guide
Item no. 31150 04871

5 TRUMPF 95 master runner with overlap arm for side cord operation
Item no. 31150 04012

6 STUDIO/TRUMPF 4-wheel runner
Item no. 31000 0004X

7 STUDIO/TRUMPF G3-Silence 2-wheel runner
Item no. 31000 0003X

The TRUMPF 95 track is attached to the corresponding support structure using the TRUMPF 95 track suspension bracket (3/ Fig. 2). The track sections are then connected to each other with TRUMPF 95 track splices (8/ Fig. 2).

The curtain is mounted on master runners followed by 2-wheel or 4-wheel runners. The STUDIO/TRUMPF G3-Silence 2-wheel runner (7/ Fig. 2) has a 360° rotatable mounting hole for the curtain in the centre and on each side an outer mounting hole for curtain hooks.

The curtain is attached to the STUDIO/TRUMPF 4-wheel-runner (6/ Fig. 2). The four load-bearing rollers and two support rollers reduce the running resistance of a curtain section and improve the running behaviour of the curtain.

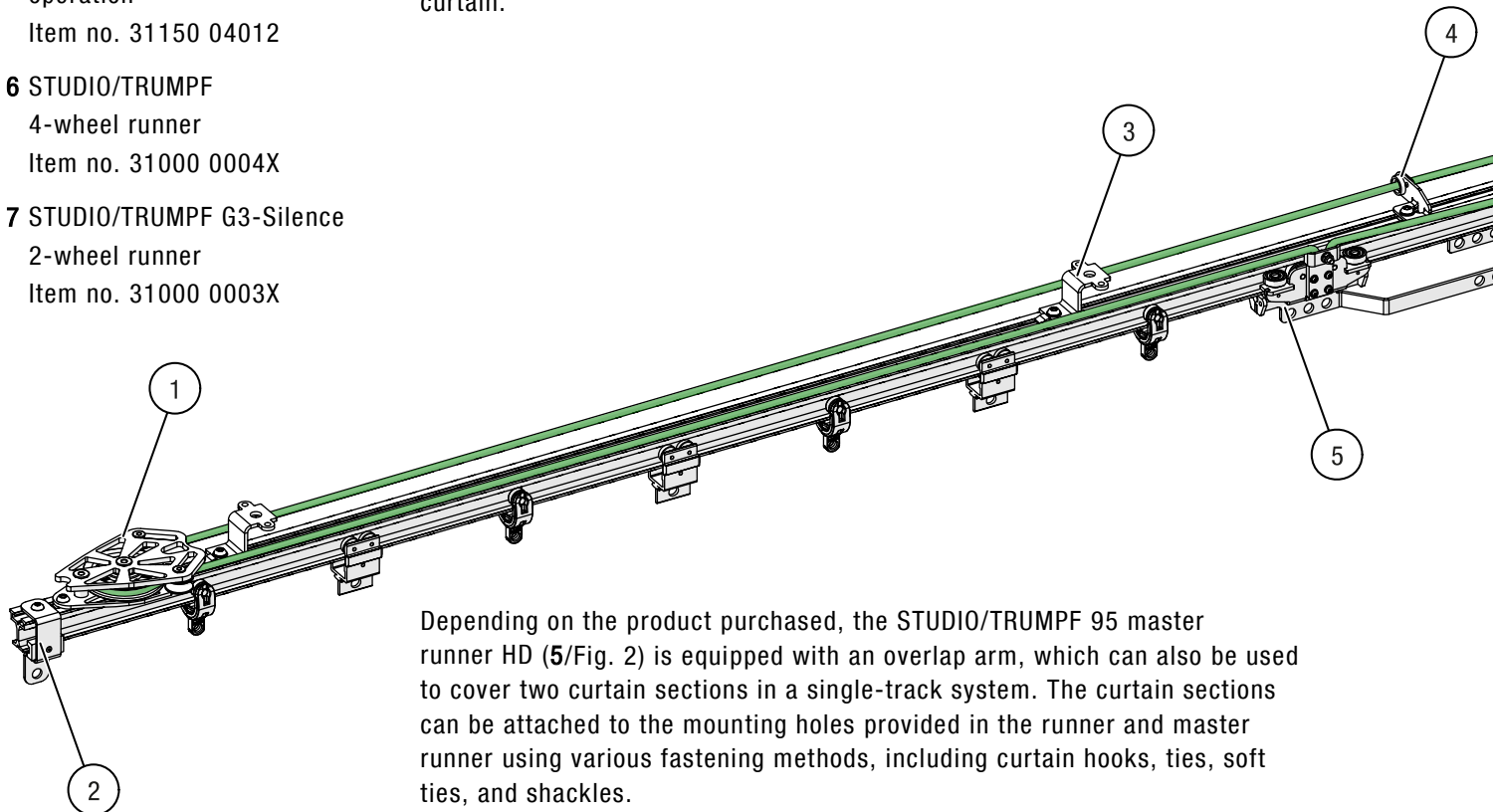

Depending on the product purchased, the STUDIO/TRUMPF 95 master runner HD (5/ Fig. 2) is equipped with an overlap arm, which can also be used to cover two curtain sections in a single-track system. The curtain sections can be attached to the mounting holes provided in the runner and master runner using various fastening methods, including curtain hooks, ties, soft ties, and shackles.

With the side cord operation, the cord is guided along the side of the track using the TRUMPF 95 side cord guide (4/ Fig. 2) and then guided back in the opposite direction using a TRUMPF 95 return pulley (1/ Fig. 2).

The STUDIO/TRUMPF 95 master runner HD for side cord operation (5/ Fig. 2) has a lateral clamping unit for the cord. The free ends of the cord can be passed through this position and securely clamped.

Number and designation (2/2):

- 8 TRUMPF 95 track splice
Item no. 31150 00061
- 9 TRUMPF 95/JOKER 95
universal head pulley
block (downwards)
Item no. 31150 00811
- 10 STUDIO/TRUMPF 95
end stop HD
Item no. 31000 0094X
- 11 Adjustable floor pulley
180 / 350
Item no. 31000 070X1

The TRUMPF 95/JOKER universal head pulley block (9/Fig. 2) is used to divert the incoming and returning cord to the floor pulley (11/Fig. 2). The optimum cord tensioning can be adjusted on the floor pulley.

Alternatively, cord courses upwards can also be realised using the TRUMPF 95/JOKER universal upward guide pulley (Item no. 31150 00821).

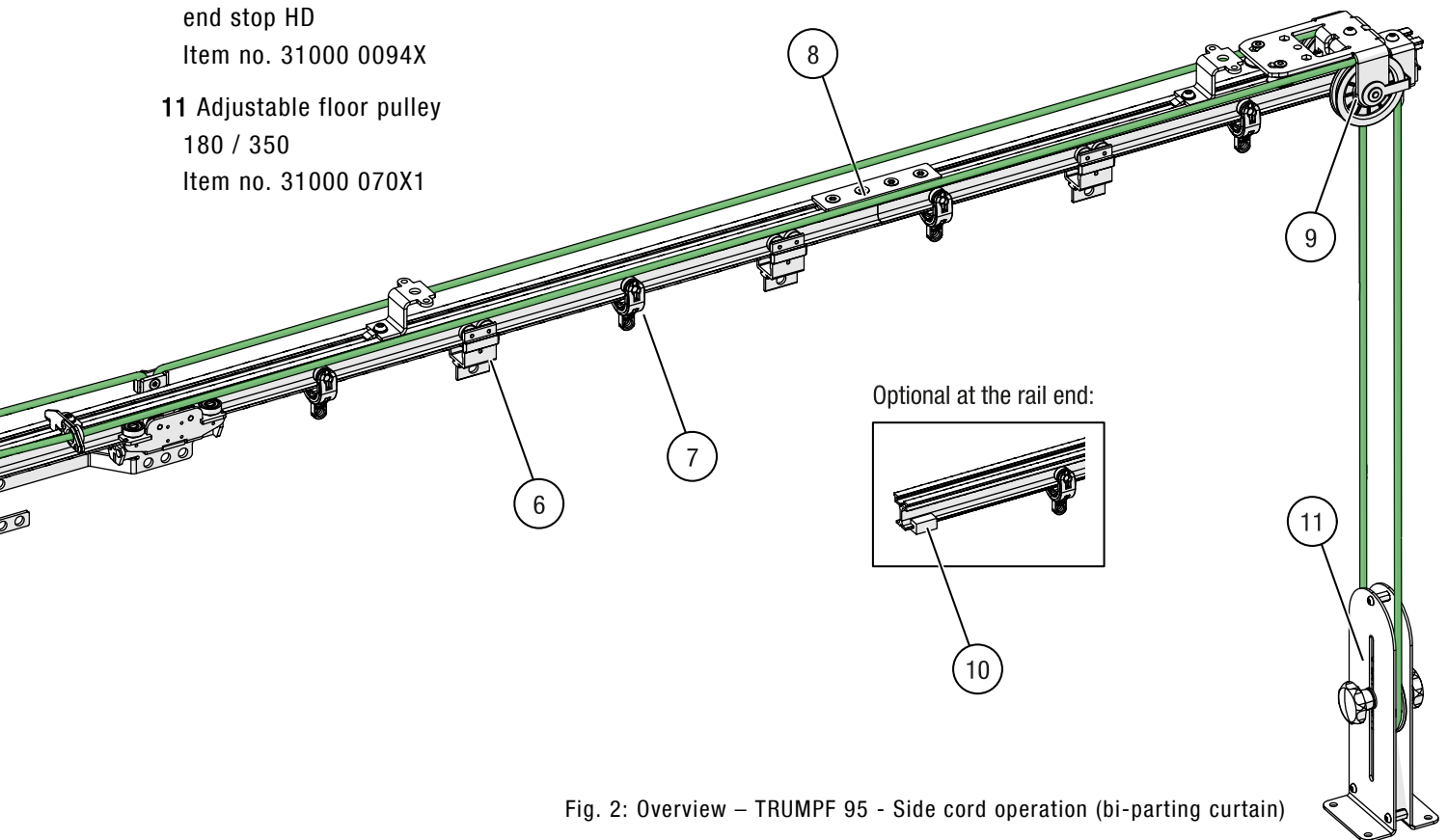

Fig. 2: Overview – TRUMPF 95 - Side cord operation (bi-parting curtain)

Rail ends

The free ends of the tracks are closed with a TRUMPF 95 end stop with curtain mounting (2/Fig. 2) or the STUDIO/TRUMPF 95 end stop HD (10/Fig. 2). The TRUMPF 95 end stop with curtain mounting has a central mounting hole to attach the curtain and to hold it in the parking position.

2.3 Overview – Top cord operation

Number and designation (1/2):

1 TRUMPF 95 return pulley
Item no. 31150 00831

2 TRUMPF 95 end stop
Item no. 31150 00981

3 TRUMPF 95 top cord track
suspension bracket
Item no. 31150 08031

4 TRUMPF 95 track splice
Item no. 31150 00061

5 TRUMPF 95 master runner for
top cord operation
Item no. 31150 03011

6 TRUMPF 95 top cord guide for
curved track sections
Item no. 31150 03875

7 TRUMPF 95 double track
suspension bracket
Item no. 31150 08021

Curved and straight track layouts of any length can be realised with the top cord operation. The cord operation takes place at the top of the track, so there is no danger of the operating cord sagging.

The TRUMPF 95 track is mounted to the corresponding support structure using the TRUMPF 95 track suspension for top cord operation (3/Fig. 3). The track sections are connected to each other with TRUMPF 95 track splices (4/Fig. 3) and can be connected to form a double track system using the TRUMPF 95 double track suspension bracket (7/Fig. 3).

There is a hole in the centre of the plate between the two tracks, which can be used for a central fastening of the system. This is particularly useful for fastening under load bars, tubular grid ceilings, and trusses.

With the top cord operation the cord is guided along the track in curved track with the TRUMPF 95 top cord guide for curved tracks (6/Fig. 3) and in straight tracks with the TRUMPF 95 top cord guide (8/Fig. 3).

A TRUMPF 95 return pulley (1/Fig. 3) is used to guide the cord back in the opposite direction.

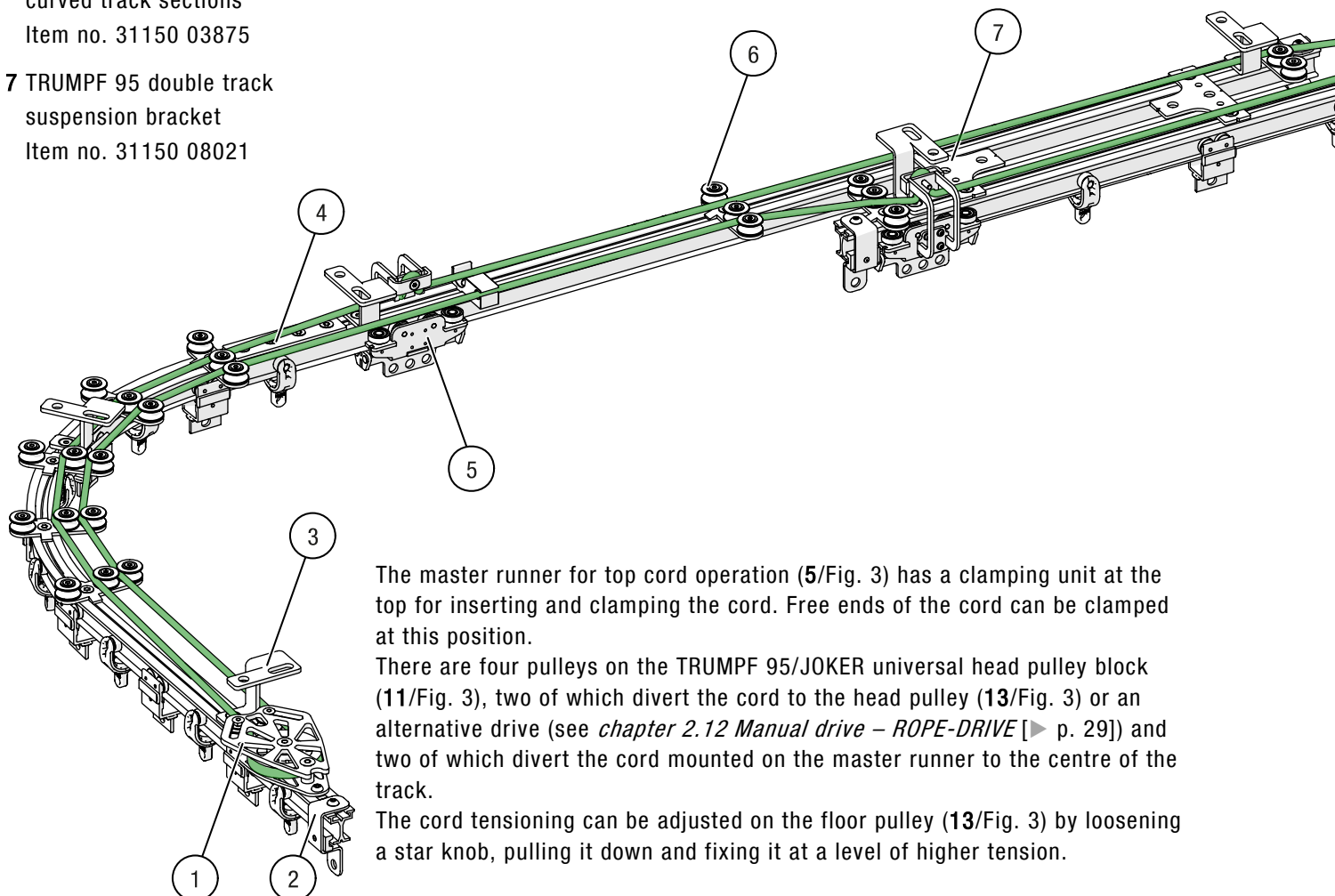

The master runner for top cord operation (5/Fig. 3) has a clamping unit at the top for inserting and clamping the cord. Free ends of the cord can be clamped at this position.

There are four pulleys on the TRUMPF 95/JOKER universal head pulley block (11/Fig. 3), two of which divert the cord to the head pulley (13/Fig. 3) or an alternative drive (see *chapter 2.12 Manual drive – ROPE-DRIVE* [► p. 29]) and two of which divert the cord mounted on the master runner to the centre of the track.

The cord tensioning can be adjusted on the floor pulley (13/Fig. 3) by loosening a star knob, pulling it down and fixing it at a level of higher tension.

Number and designation (2/2):**8** TRUMPF 95 top cord guide

Item no. 31150 03871

9 STUDIO/TRUMPF

4-wheel-runner

Item no. 31000 0004X

10 STUDIO/TRUMPF G3-Silence

2-wheel runner

Item no. 31000 0003X

11 TRUMPF 95/JOKER 95universal head pulley
block (downwards)

Item no. 31150 00811

The free ends of the tracks are closed with a TRUMPF 95 end stop with curtain mounting (2/ Fig. 3) or the STUDIO/TRUMPF 95 end stop HD (12/ Fig. 3). The TRUMPF 95 end stop with curtain mounting has a central mounting hole to attach the curtain and hold it in the parking position.

The curtain is mounted on master runners followed by 2-wheel or 4-wheel runners: The STUDIO/TRUMPF G3-Silence 2-wheel runner (10/ Fig. 3) has a 360° rotatable mounting hole for the curtain in the centre and on each side an outer mounting hole for curtain hooks.

The curtain can also be attached to the STUDIO/TRUMPF 4-wheel-runner (9/ Fig. 3). The four support rollers and two support rollers reduce the running resistance of the curtain section and improve the running behaviour of the curtain. This is particularly noticeable on tight radii.

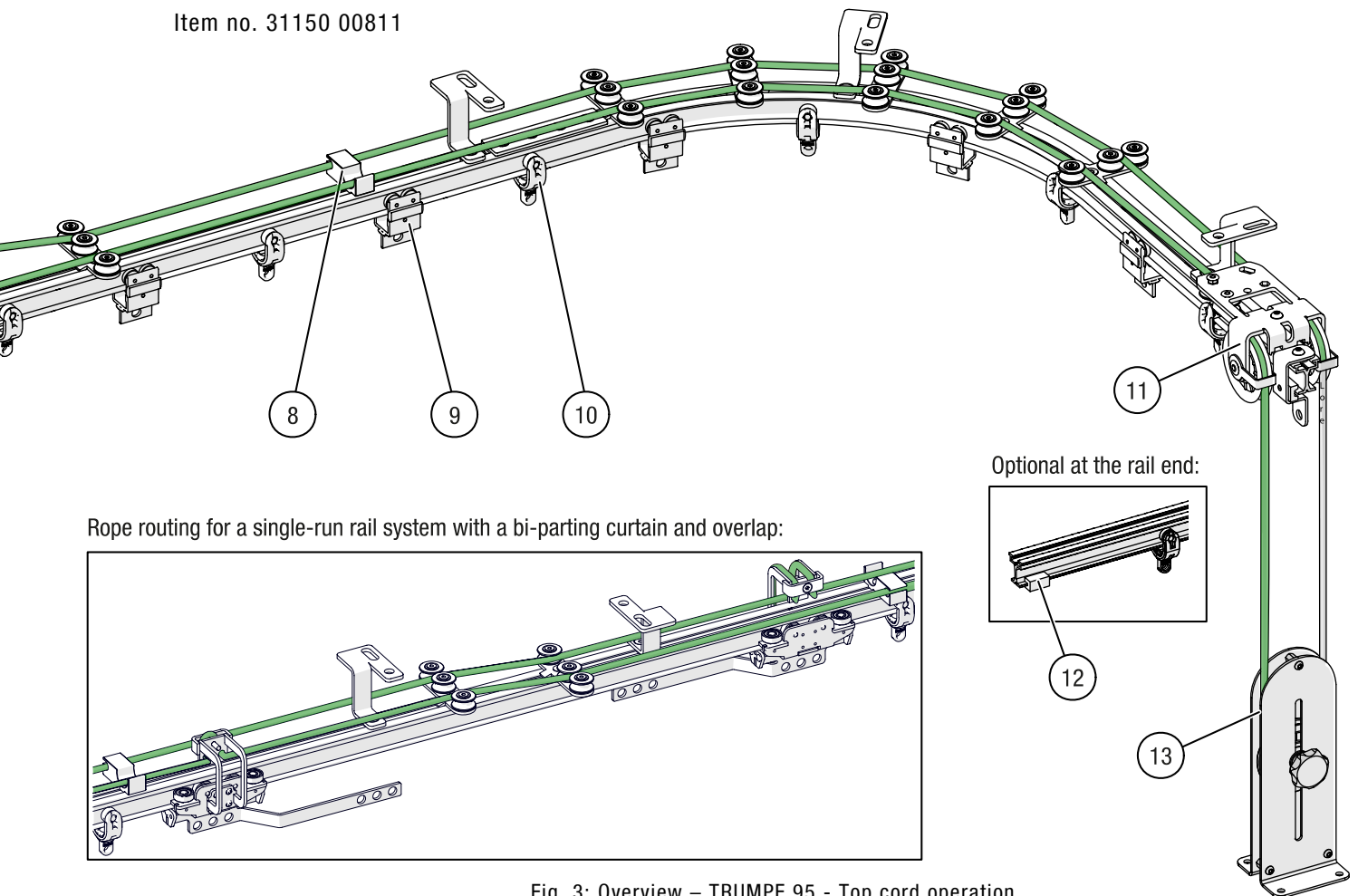

Rope routing for a single-run rail system with a bi-parting curtain and overlap:

12 STUDIO/TRUMPF 95

end stop HD

Item no. 31000 0094X

13 Adjustable floor pulley

Item no. 31000 070X1

Fig. 3: Overview – TRUMPF 95 - Top cord operation

Depending on the product purchased, the STUDIO/TRUMPF 95 master runner for top cord operation (5/ Fig. 3) is equipped with an overlap arm, which can also be used to cover two curtain sections in a single-runner system. The curtain sections can be attached to the holes provided in the runner and master runner using various types of fastening, including curtain hooks, ties, soft ties, and shackles.

2.4 Overview – Double top cord operation

Number and designation (1/2):

- 1 TRUMPF 95 end stop
Item no. 31150 00981
- 2 TRUMPF 95 return pulley for
double top cord operation
Item no. 31150 05831
- 3 TRUMPF 95 double top cord
guide, straight
Item no. 31150 05871
- 4 TRUMPF 95 master runner for
double top cord operation
Item no. 31150 05061
- 5 TRUMPF 95 track suspension
for double top cord operation
Item no. 31150 08051
- 6 TRUMPF 95 track splice
Item no. 31150 00061

The double top cord operation is a further development of the top cord operation. With two independent cord operations, two master runners can be moved independently of each other on one track. This means that curtain sections with different speeds and/or travel distances can be realised with one track system.

The opening variants are extremely variable with this type of cord guide. A curtain section can be opened both from left to right and from right to left. The curtain can be moved along the track in a stretched or collapsed state. This type of cord guide is usually used when different travel paths or speeds are required, e.g. for asymmetrical opening patterns.

The TRUMPF 95 track is fixed to the corresponding support structure using the TRUMPF 95 track suspension for double top cord operation (5/ Fig. 4). The track sections are connected to each other with TRUMPF 95 track splices (6/ Fig. 4) and can be connected to form a double system using the TRUMPF 95 double track suspension bracket (7/ Fig. 4) to form a double track system.

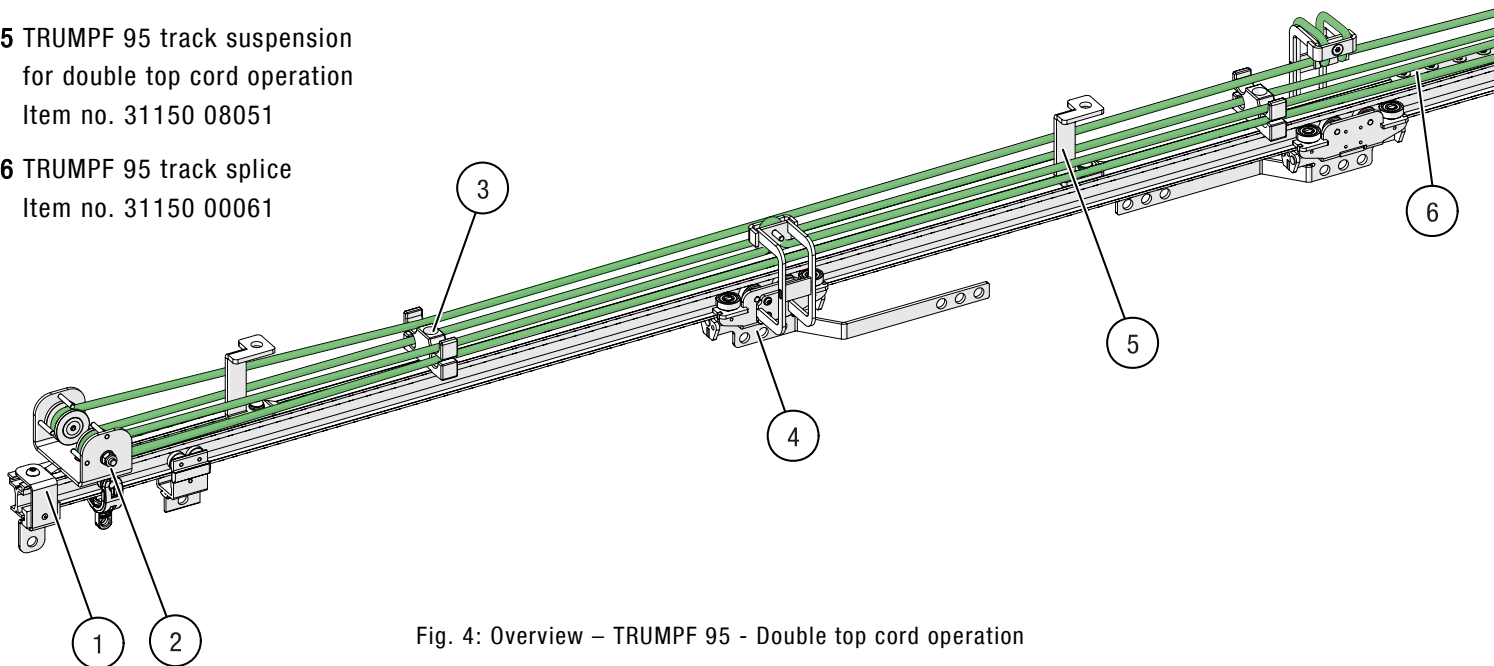

Fig. 4: Overview – TRUMPF 95 - Double top cord operation

- 7 TRUMPF 95 double track
suspension bracket
Item no. 31150 08021

With the TRUMPF 95 double track suspension bracket (7/ Fig. 4), there is a hole in the centre between the two tracks on the plate, which can be used to fasten the system in the centre. This is particularly helpful when fixing under load bars, tubular grid ceilings, and trusses.

In double top cord operation, the cord is guided along the track in curved tracks with the TRUMPF 95 cord guide (8/ Fig. 4) and in straight track layouts with the TRUMPF 95 straight cord guide (3/ Fig. 4). A TRUMPF 95 return pulley (2/ Fig. 4) is used to deflect the cord in the opposite direction.

The TRUMPF 95 master runner for double top cord operation (4/ Fig. 4) has a clamping unit at the top for inserting and clamping the cord. Free ends of the cord can still be secured at this position.

On the TRUMPF 95 head pulley (11/ Fig. 4), the incoming and outgoing cord is diverted on both sides to a floor pulley (13/ Fig. 4). The optimum cord tensioning can be set on the floor pulley.

Number and designation (2/2):

8 TRUMPF 95 double top cord
guide for curved tracks
Item no. 31150 05875

9 STUDIO/TRUMPF 4-wheel
runner
Item no. 31000 0004X

10 STUDIO/TRUMPF G3-Silence
2-wheel-runner
Item no. 31000 0003X

The free ends of the tracks are closed with a TRUMPF 95 end stop with curtain mounting (1/ Fig. 4) or the STUDIO/TRUMPF 95 end stop HD (12/ Fig. 4). The TRUMPF 95 end stop with curtain mounting has a central mounting hole to attach the curtain and hold it in the parking position. The curtain is mounted on master runners followed by 2-wheel- or 4-wheel runners:

The STUDIO/TRUMPF G3-Silence 2-wheel runner (10/ Fig. 4) has a 360° rotatable mounting hole for the curtain in the centre and on each side an outer mounting hole for curtain hooks.

The curtain can also be attached to the STUDIO/TRUMPF 4-wheel-runner (9/ Fig. 4). The four support rollers and two support rollers reduce the running resistance of a curtain section and improve the running behaviour of the curtain. This is particularly noticeable on tight radii.

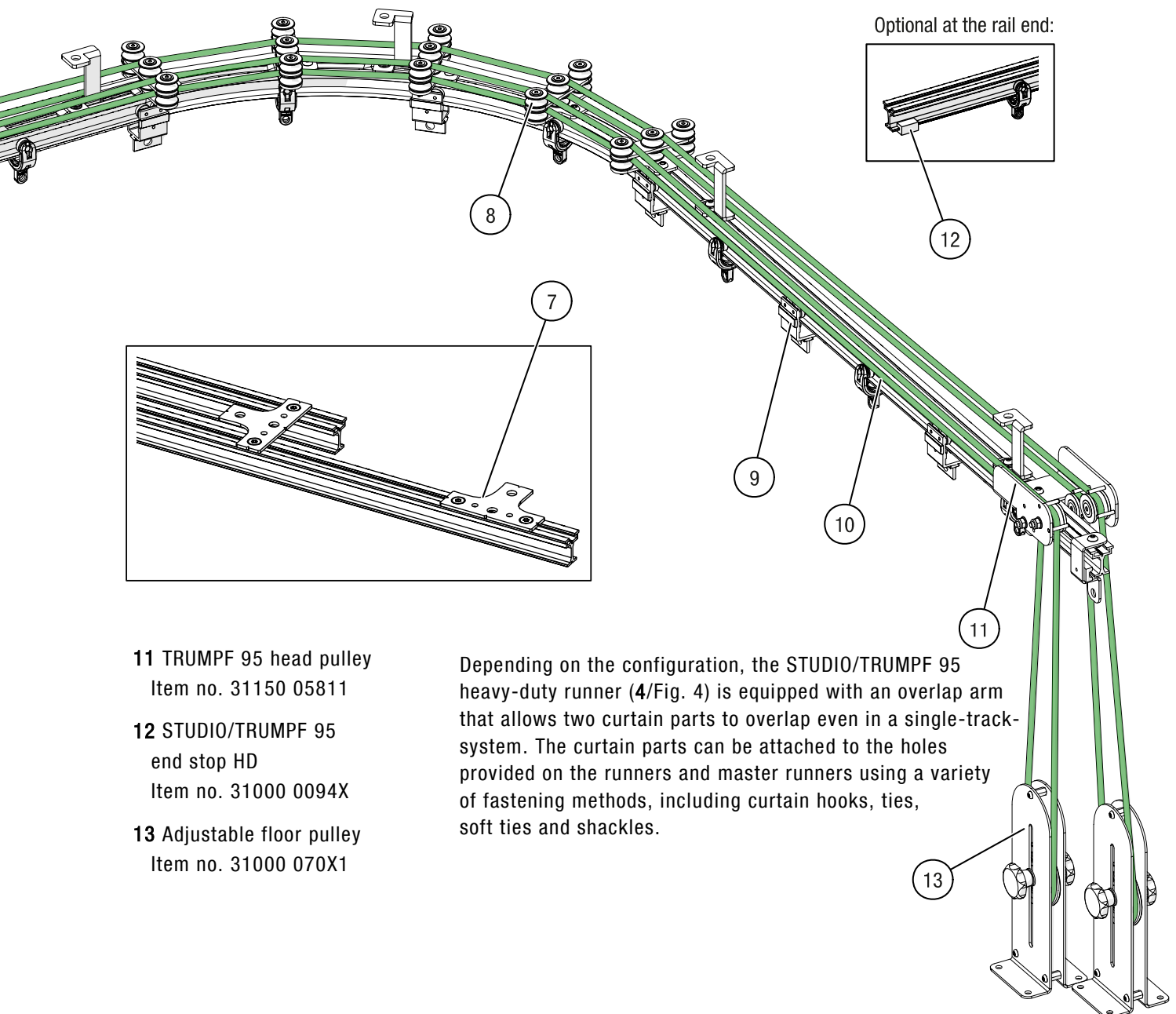

11 TRUMPF 95 head pulley
Item no. 31150 05811

12 STUDIO/TRUMPF 95
end stop HD
Item no. 31000 0094X

13 Adjustable floor pulley
Item no. 31000 070X1

Depending on the configuration, the STUDIO/TRUMPF 95 heavy-duty runner (4/ Fig. 4) is equipped with an overlap arm that allows two curtain parts to overlap even in a single-track-system. The curtain parts can be attached to the holes provided on the runners and master runners using a variety of fastening methods, including curtain hooks, ties, soft ties and shackles.

2.5 Track switch

Application

The track switches are additional devices for the Gerriets TRUMPF 95 and STUDIO / E curtain track systems for stage and studio use, which enable complex track layouts with branches.

- Various backgrounds or displays can be held in “park position” on their own tracks
- The storage space can be distributed over several track sections positioned one behind the other
- They can be used for flexible scenery set-ups for scenic set changes
- Scenery can be moved and stored on track sections, for example, in other stage areas

Drive

The track switch is moved manually via a polyester cord or by an electric motor. Track switches can be used in conjunction with walk-along tracks or electric FRICTION DRIVE motors (only with festoon cord). Curtain pull systems with cord operation are not compatible.

Versions

There are six versions of the track switch corresponding to the number of inputs and outputs: 1 to 2, 1 to 3 and 2 to 3, each with manual or electrical drive. The numbers correspond to the switch positions or inputs and outputs of the track switch (see the illustrations of the switch positions Fig. 8, Fig. 9 and Fig. 10).

2.5.1 Manual track switch

- Track switch 1 to 2
Item no. 31150 01101
- Track switch 1 to 3
Item no. 31150 01111
- Track switch 2 to 3
Item no. 31150 01131

The manual drive via an 8 mm cord adjusts the rotating track finger (3/ Fig. 5) to the respective track positions (1/ Fig. 5). The unlocked track ends are secured via a rotating flap (2/ Fig. 5). The operating cord (5/ Fig. 5) is used to move the track finger to the desired switch position.

Number and designation:

- 1 Track position 1-3
- 2 Turning flap for securing the track ends
- 3 Rotatable track finger
- 4 Track end opposite side
- 5 Operating cord

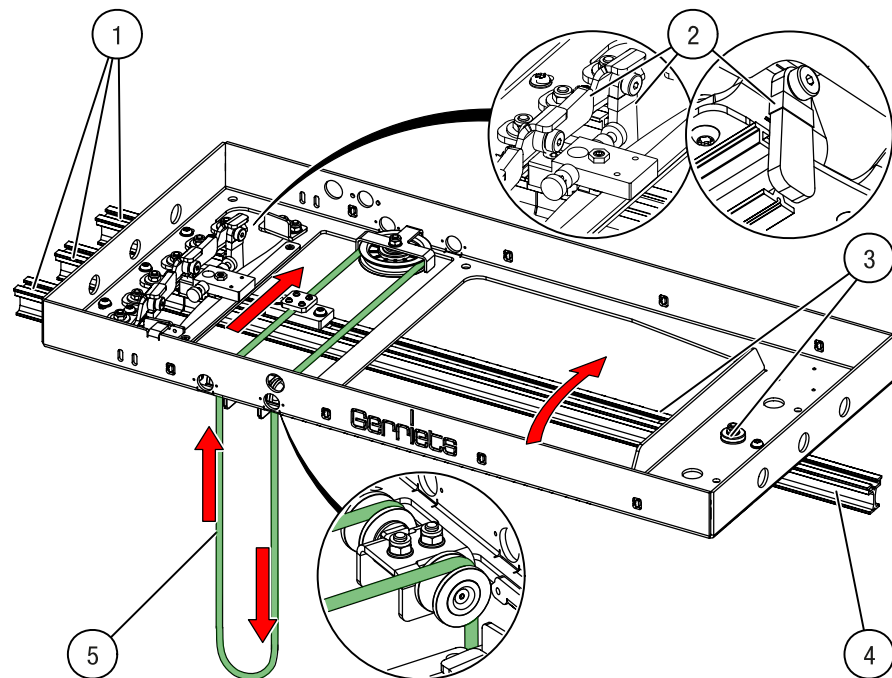

Fig. 5: Manual track switch 1 to 3 (example)

2.5.2 Motor driven track switch with switch control

- Track switch 1 to 2
Item no. 31150 01141
- Track switch 1 to 3
Item no. 31150 01151
- Track switch 2 to 3
Item no. 31150 01171

The electrical drive (1/ Fig. 6) uses a threaded spindle to move the rotating track finger (5/ Fig. 6) to the respective track ends (3/ Fig. 6). The open track ends are secured via a rotary flap (2/ Fig. 6). The limit switch signals to the control system when the respective end position is reached.

Number and designation:

- 1 Electrical drive
- 2 Swivel flap for securing the track end
- 3 Track end 1 – 2
- 4 Limit switches
- 5 Rotatable track finger
- 6 Terminal box
- 7 Track end opposite side

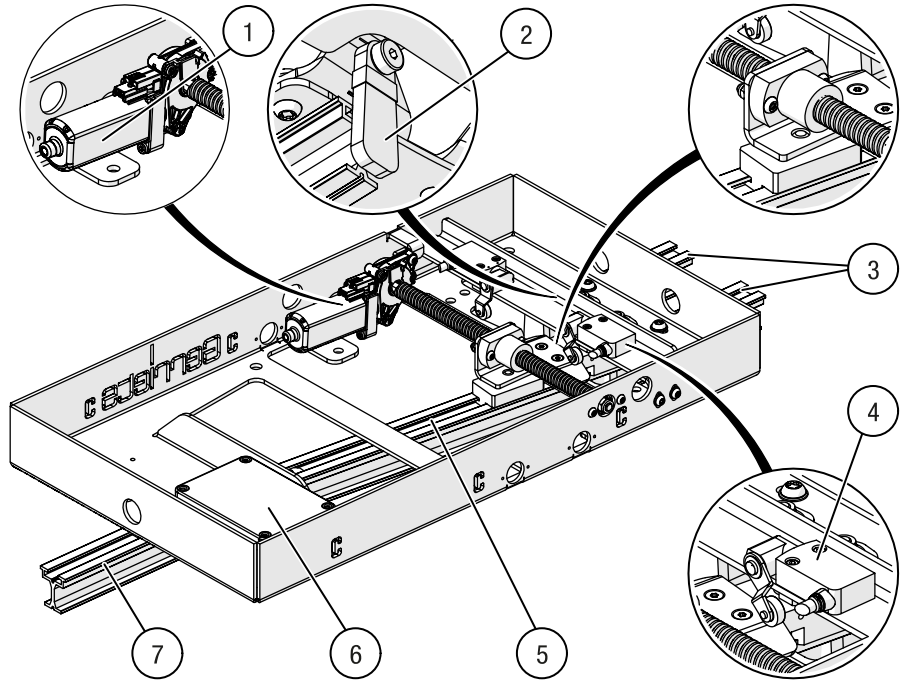

Fig. 6: Track switch 1 to 2 electrical (example)

- Track switch control G-FRAME 54
Item no. 31900 05031
- Control and supply cable
Item no. 31900 05111

The main circuit breaker (4/ Fig. 7) disconnects or connects the control system to the mains and can be secured with a padlock when switched off (0 position). The “On” indicator light (1/ Fig. 7) signals the switched-on state. In the event of a malfunction or foreseeable incorrect use the “Stop” button (2/ Fig. 7) can be used to stop the track switch immediately. The buttons 1 to 3 (3/ Fig. 7) can be used to move the track fingers to the corresponding switch positions.

Number and designation:

- 1 “On” indicator light
- 2 stop buttons
- 3 Position 1 – 3
- 4 Main circuit breaker

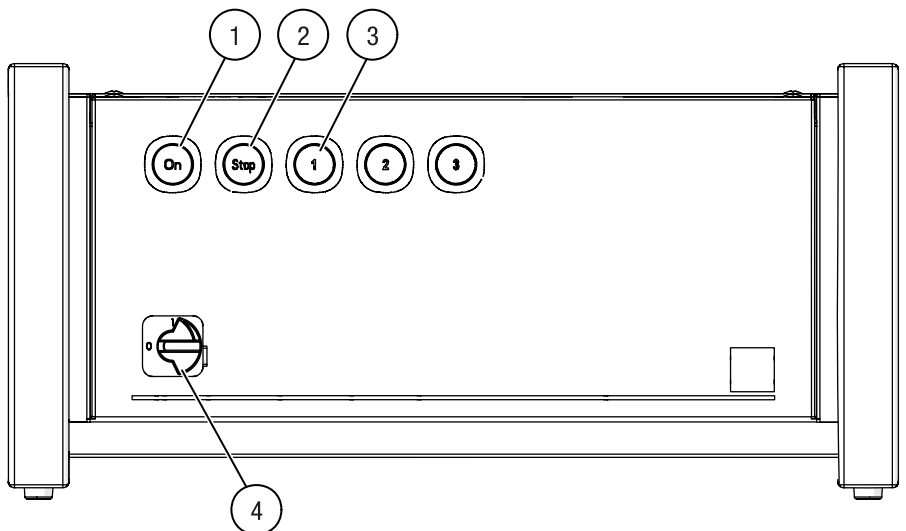

Fig. 7: Switch control G-FRAME 54 – 1 to 3

2.5.3 Track switch positions

The track switch positions are only shown below for the manual track switch.

Track switch positions:
Manual track switch 1 to 3

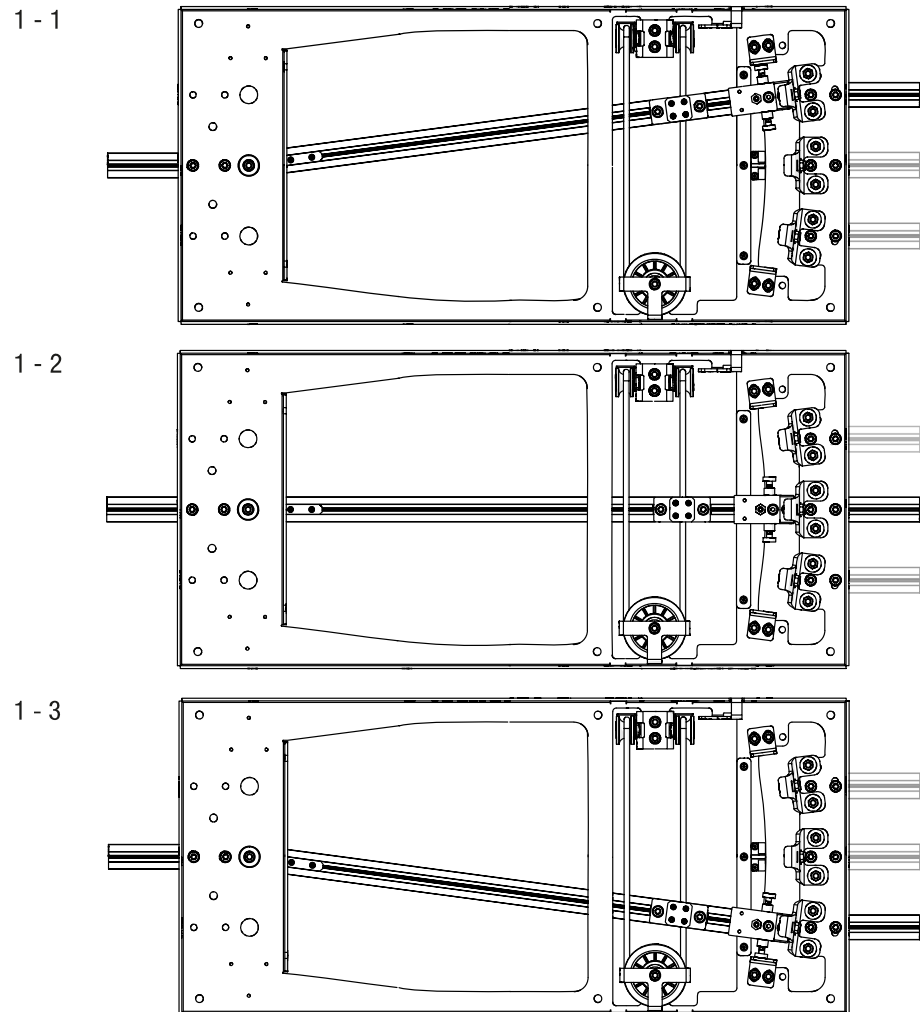

Fig. 8: Track switch 1 to 3 manual – Track switch positions

Track switch positions:
Manual track switch 1 to 2

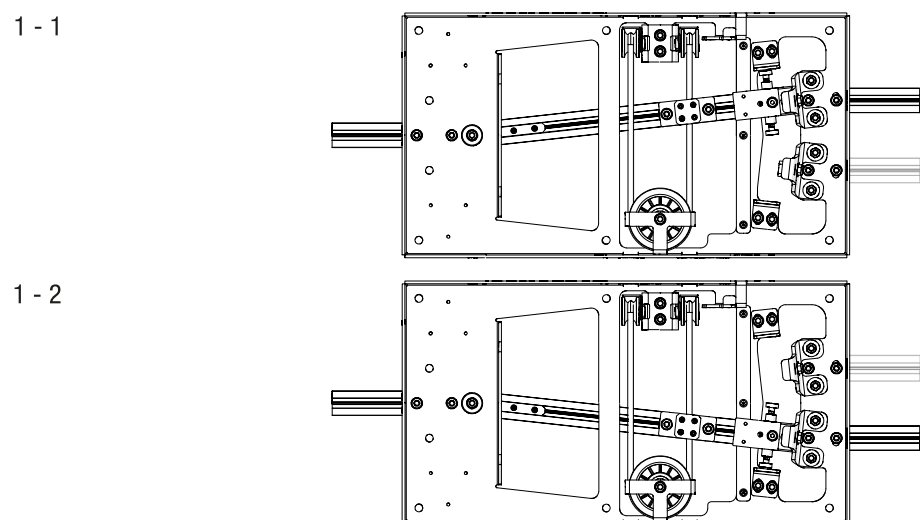
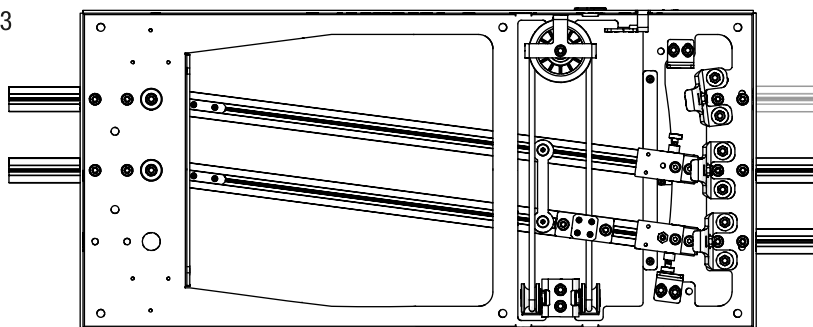

Fig. 9: Track switch 1 to 2 manual – Track switch positions

Track switch positions:
Manual track switch 2 to 3

1/2 - 2/3



1/1 - 2/2

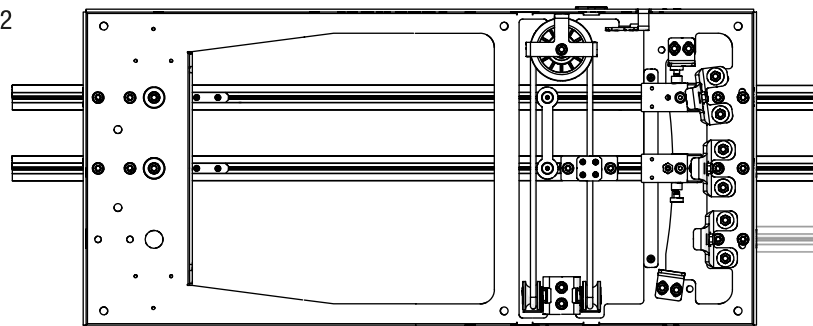

Fig. 10: Track switch 2 to 3 manual – Track switch positions

2.6 Suspension variants

Number and designation:

1 TRUMPF 95 G-CLAMP 48/60

incl. fastening elements
Item no. 31150 08091

2 Track suspension bracket
for top cord operation

incl. slot nut
Item no. 31150 08031

3 G-CLAMP 48/60 incl.

incl. fastening elements for
assembly with suspensions
Item no. 31000 08091

4 Track suspension bracket
for double top cord operations

incl. slot nut
Item no. 31150 08051

5 G-TWIST II central mounting

Item no. 31150 0811X

6 Track suspension bracket
for side cord operations

incl. slot nut
Item no. 31150 08041

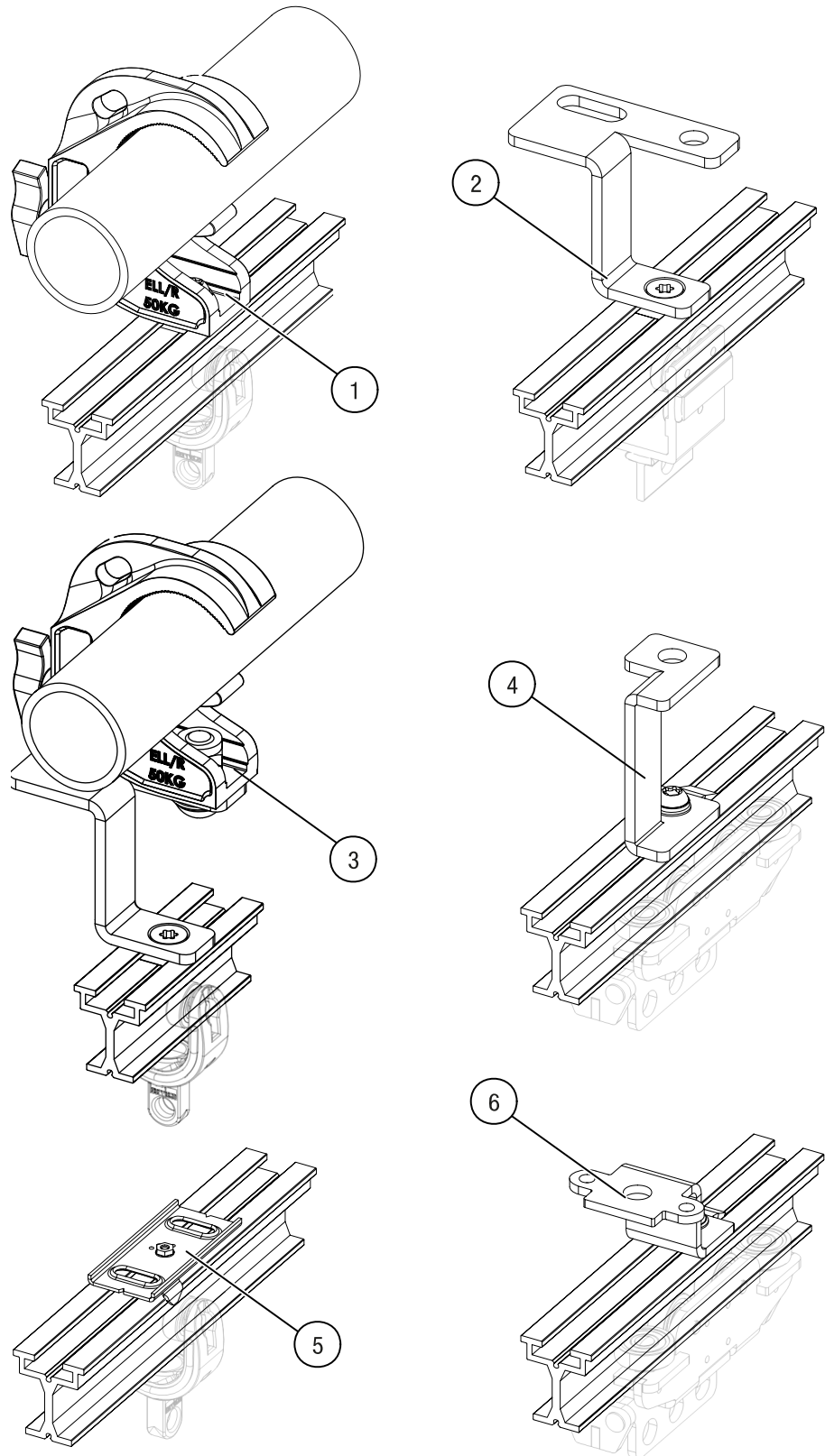

Fig. 11: TRUMPF 95 – Suspension variants

Number and designation:

1 Wall mount bracket 150, 250 and 380
incl. fastening elements for
assembly on suspensions
(suspension not included)
Item no. 31000 088XX

2 TRUMPF 95 wall mount bracket
150, 250 and 380 incl.
fastening elements direct track
mounting
Item no. 31150 088XX

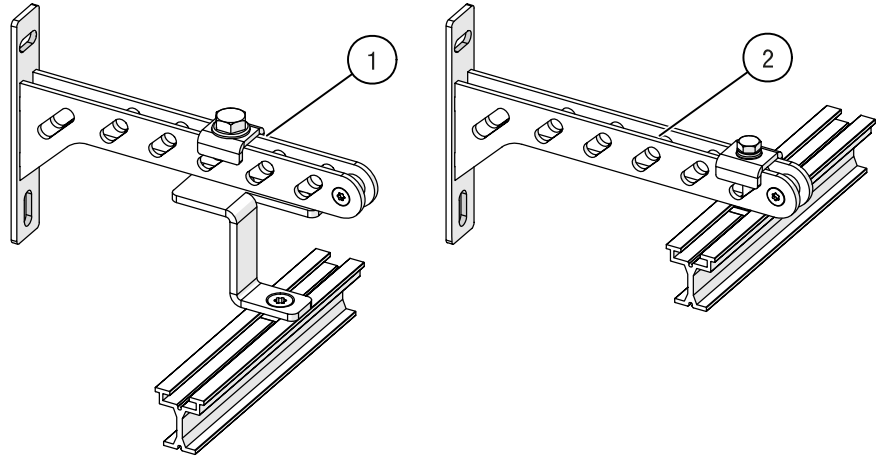

Fig. 12: TRUMPF 95 – Wall mount bracket on suspension (left; track suspension as an example) and direct mounting on track (right)

2.7 Master and special runners – Walk-along track

TRUMPF 95/STUDIO
 master runner HD
 Item no. 31000 00051
 TRUMPF 95/STUDIO master runner
 HD with overlap arm
 Item no. 31000 00061

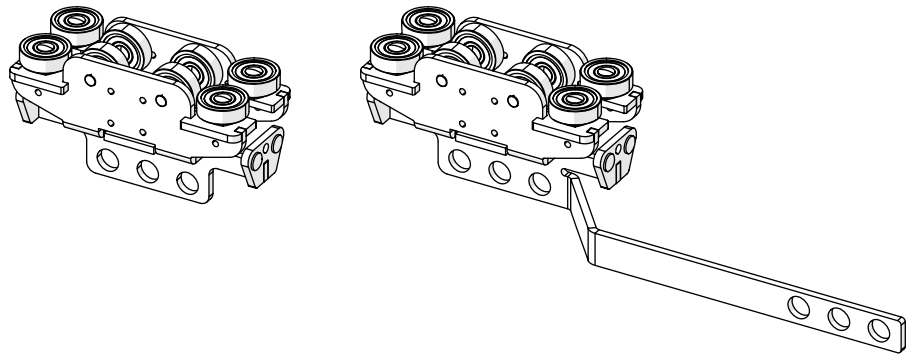

Fig. 13: Master runner HD (left) and master runner HD with overlap arm (right)

STUDIO/TRUMPF
 4-wheel-runner: 4 + 4 (left)
 Item no. 31000 00045
 4-wheel-runner: 4 + 2 (right)
 Item no. 31000 00041

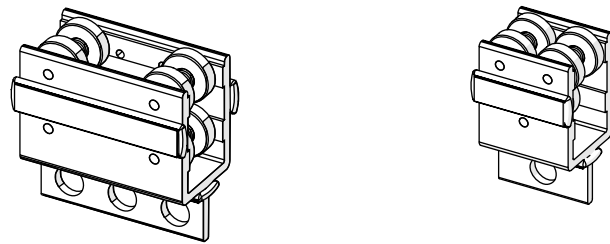

Fig. 14: Runner 4 + 4 (left) and runner 4 + 2 (right)

HD master runner with screw
 brake
 Item no. 31000 00108 – (Fig. 15
 left)

HD scenery runner with scenery
 attachment
 Item no. 31000 00101 – (Fig. 15
 right)

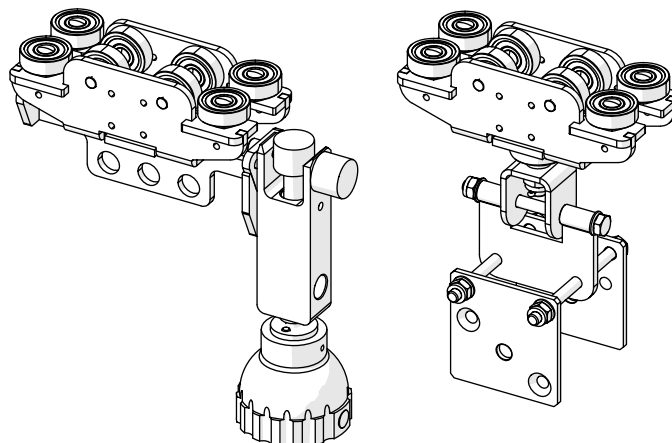

Fig. 15: HD braked runner (left) and scenery runner (right)

TRUMPF 95/STUDIO HD master
 runner (Fig. 15 left) (screw or
 spring brake)
 Item no. 31000 0010X

The STUDIO/TRUMPF 95 master runner HD (braked; see Fig. 15 left) can be locked on the track with an operating pole (see *chapter 2.11 Accessories and spare parts* [► p. 27]) by turning the yellow operating cap.

STUDIO/TRUMPF 95
swivel pipe
Item no. 31000 001XX

The swivel pipe is mounted on a STUDIO/TRUMPF 95 master runner HD and can be freely positioned in the track system. It has a continuously adjustable turntable (1/Fig. 16) with a scale in 15° increments and a \varnothing 50 mm aluminium tube for holding the curtain alley. At the end of the swivelling pipe, there is a stop for the securing of the outer tie (4/Fig. 16).

The swivel pipe is adjusted using two operating caps with an operating pole (see *chapter 2.11 Accessories and spare parts* [► p. 27]).

The blue operating cap (2/Fig. 16) is used to set the angle and the yellow operating cap (3/Fig. 16) is used to release or lock the brake to stop on the track.

Number and designation:

- 1 Turntable
- 2 Operating cap for releasing a rotary movement (blue)
- 3 Operating cap as runner brake (yellow)
- 4 Stop for securing the outer tie

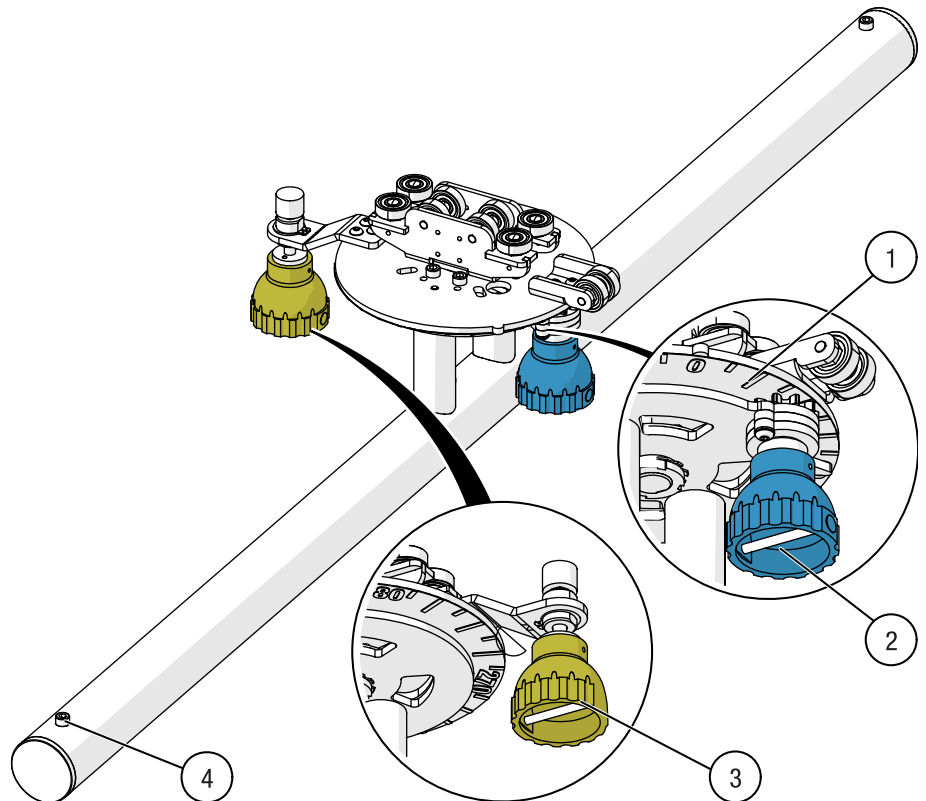

Fig. 16: TRUMPF 95 – Swivel pipe

2.8 Master and scenery runners – Side cord operation



Optional limit switch arm – design may vary depending on the drive ordered. Please refer to the additional documentation for your complete system.

TRUMPF 95 master runner HD
(Fig. 17 left)
Item no. 31150 04011

TRUMPF 95 master runner HD
with limit switch arm (Fig. 17 left)
Item no. 31150 04014

TRUMPF 95 master runner HD
with overlap arm and limit switch
arm (Fig. 17 right)
Item no. 31150 04015

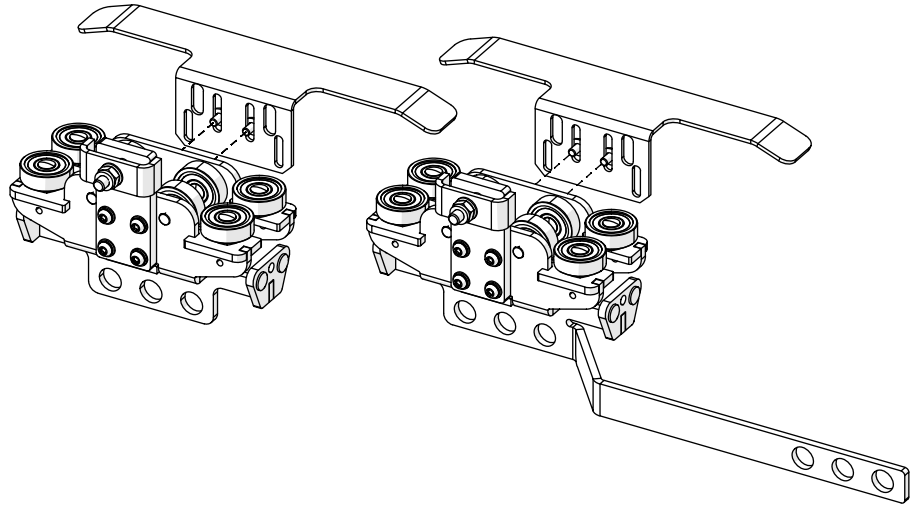

Fig. 17: TRUMPF 95 master runner HD with limit switch arm (left) and TRUMPF 95 master runner HD with overlap arm and limit switch arm (right)

Master runner HD as scenery
runner with scenery attachment
Item no. 31150 04013

Master runner HD as scenery
runner with scenery attachment
and limit switch arm
Item no. 31150 04016

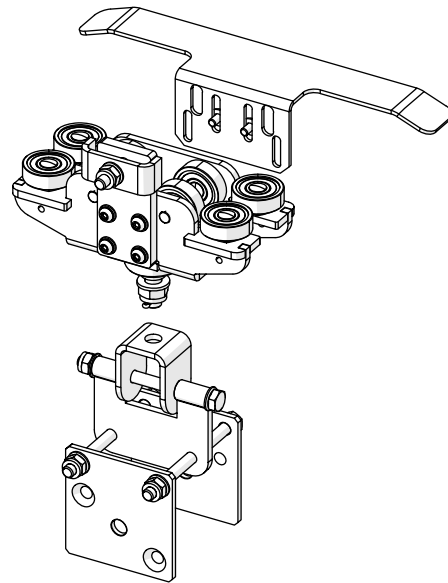

Fig. 18: Master runner HD as scenery runner with scenery attachment with limit switch arm

The load under the scenery runner is cardanic mounted.

2.9 Master and scenery runners – Top cord operation



Optional limit switch arm – design may vary depending on the drive ordered. Please refer to the additional documentation for your complete system.

TRUMPF 95 master runner HD
Item no. 31150 03011

TRUMPF 95 master runner HD
with limit switch arm
Item no. 31150 03014

TRUMPF 95 master runner HD
with overlap arm
Item no. 31150 03012

TRUMPF 95 master runner HD
with overlap and limit switch arm
Item no. 31150 03015

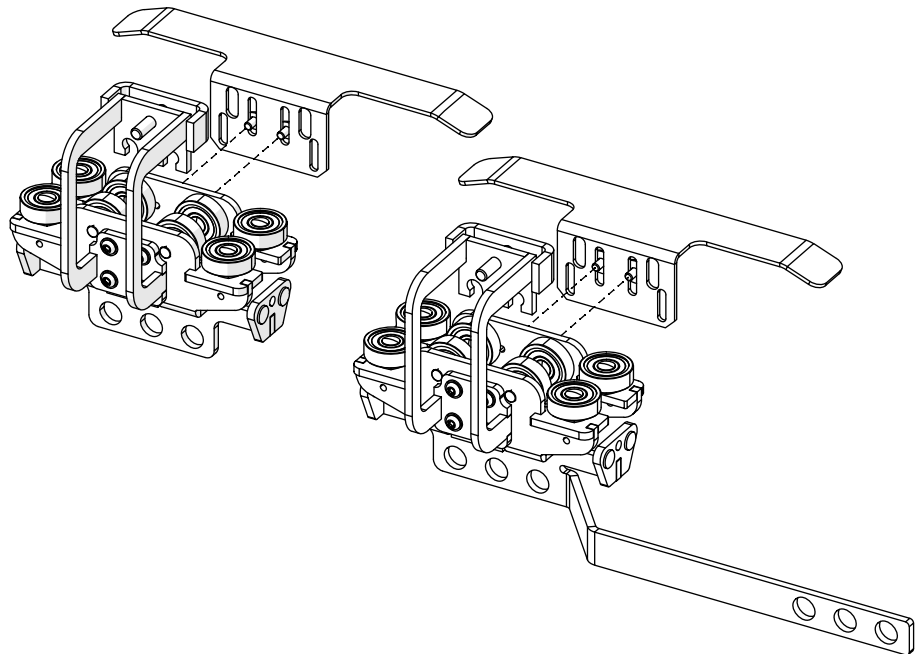

Fig. 19: TRUMPF 95 master runner HD with limit switch arm (left) and master runner HD with overlap arm and limit switch arm (right)

Master runner HD as scenery
runner with scenery attachment
Item no. 31150 03013

Master runner HD as scenery
runner with scenery attachment
and limit switch arm
Item no. 31150 03016

The load under the scenery runner is cardanic mounted.

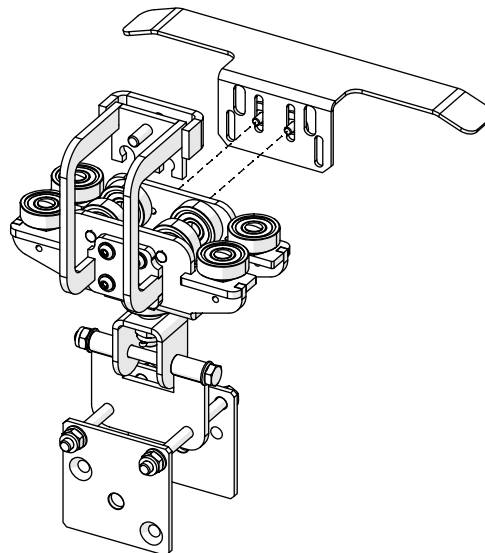

Fig. 20: Master runner HD as scenery runner with scenery attachment with limit switch arm

2.10 Master and scenery runners – Double top cord operation

TRUMPF 95 master runner HD
Item no. 31150 05061

TRUMPF 95 master runner HD
with overlap arm
Item no. 31150 05062

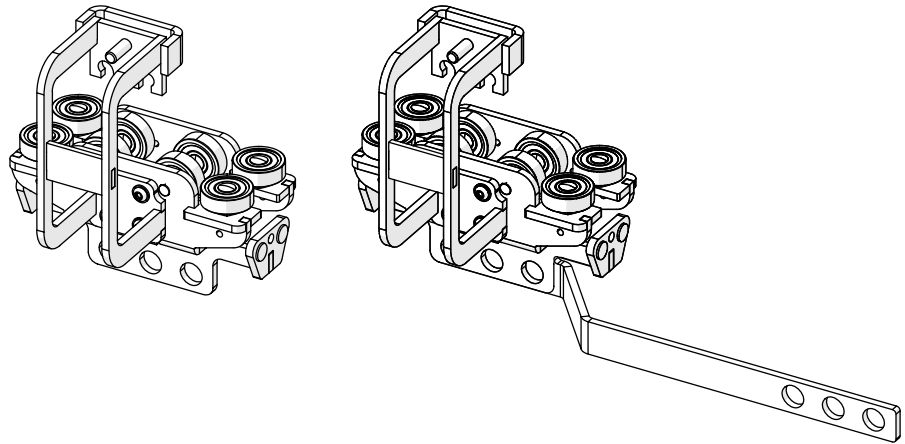

Fig. 21: TRUMPF 95 master runner HD (left) and master runner HD with overlap arm (right) for double top cord operation

Master runner as scenery runner
with scenery attachment
Item no. 31150 05063

The load under the scenery runner is cardanic mounted.

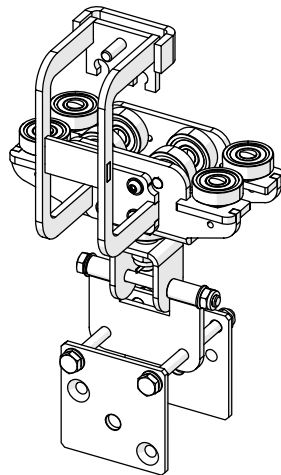

Fig. 22: Master runner HD as scenery runner with scenery attachment for double top cord operation

2.11 Accessories and spare parts

! NOTICE

Material damage due to non-original spare parts and accessories

The use of parts from other manufacturers may impair the proper functioning of the TRUMPF 95 track system and lead to malfunctions or damage to the system or third-party property.

➔ Only use original parts and accessories from Gerriets GmbH.

Number and designation:

- 1 HD slot nut
Item no. 31150 00152
- 2 Slide-in slot nut
Item no. 31150 00111
- 3 Slot nut
Item no. 31150 00144
- 4 TRUMPF/TRUMPF 95
connection pins touring
(set of 10)
Item no. 31000 09117
- 5 TRUMPF/TRUMPF 95 joint pins
(set of 10)
Item no. 31000 09115
- 6 Polyester cord Ø 8 mm
Item no. 41040 0118X
- 7 TRUMPF 95 track splice
Item no. 31150 00061

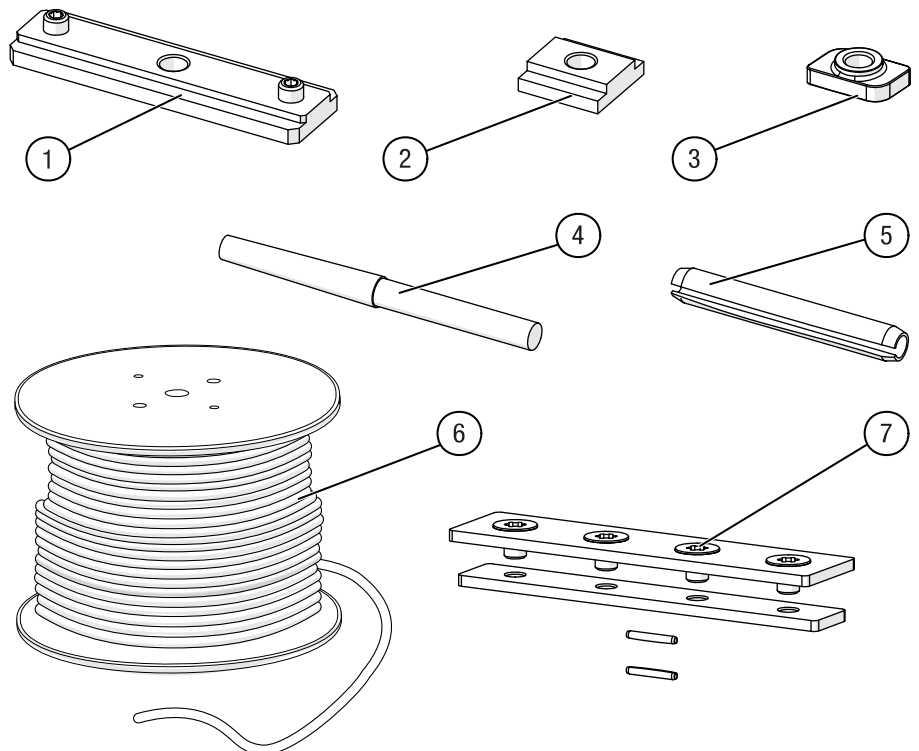

Fig. 23: Accessories – TRUMPF 95 track system

The stainless-steel connecting pins (4/Fig. 23) are reusable and conical on one side for quick and easy assembly and disassembly of the tracks. They are used for recurring assembly and disassembly work.

Operating pole

Item no. 43080 003XX

The operating pole can be used to adjust spotlights, swivel pipes, and braked master runners at a great height. There is a hook at the end of the rod which is hooked into the corresponding counterpart. The device to be adjusted is released or fixed by turning the remote-control rod (see Fig. 24).

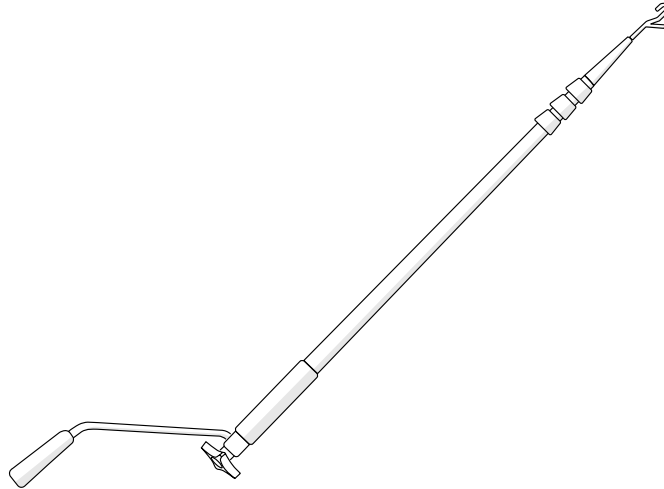

Fig. 24: Accessories – Operating pole (schematic diagram)

TRUMPF 95 limit switch arm

Item no. 31150 07131

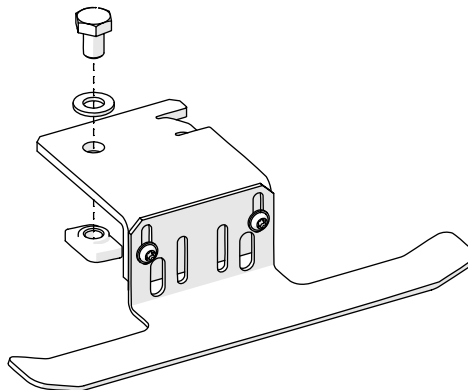

Fig. 25: Accessories – FRICTION DRIVE limit switch arm

2.12 Manual drive – ROPE-DRIVE

Number and designation:

- 1 TRUMPF 95 TRAC-DRIVE mounting bracket
Item no. 31150 09011
- 2 Hemp rope wheel
- 3 Hemp rope floor pulley
- 4 Clamping unit
- 5 Threaded pin for adjustment the cord tensioning
- 6 Head pulley

The ROPE-DRIVE drive (Item no. 31000 07101) enables the \varnothing 8 mm operating cord to be driven manually using an endless hemp rope (max. \varnothing 22 mm). It is attached to the track profile below the head pulley (6/Fig. 26) using the mounting bracket (1/Fig. 26).

The operating cord (shown in blue) and the hemp rope (shown in green) each form their own closed circuits with power transmission via the ROPE-DRIVE. The hemp rope is tensioned on the hemp rope wheel (2/Fig. 26) and in the hemp rope floor pulley (3/Fig. 26).

The polyester operating cord in the upper circuit runs in the track layout to the tensioning unit (4/Fig. 26) via the head pulley (6/Fig. 26). A spring is tensioned in the tensioning unit during operation, which compensates for any cord elongation in the operating cord and maintains the cord tensioning.

The threaded pin (5/Fig. 26) completely relieves the spring tension and the cord can be freely suspended or unhooked.

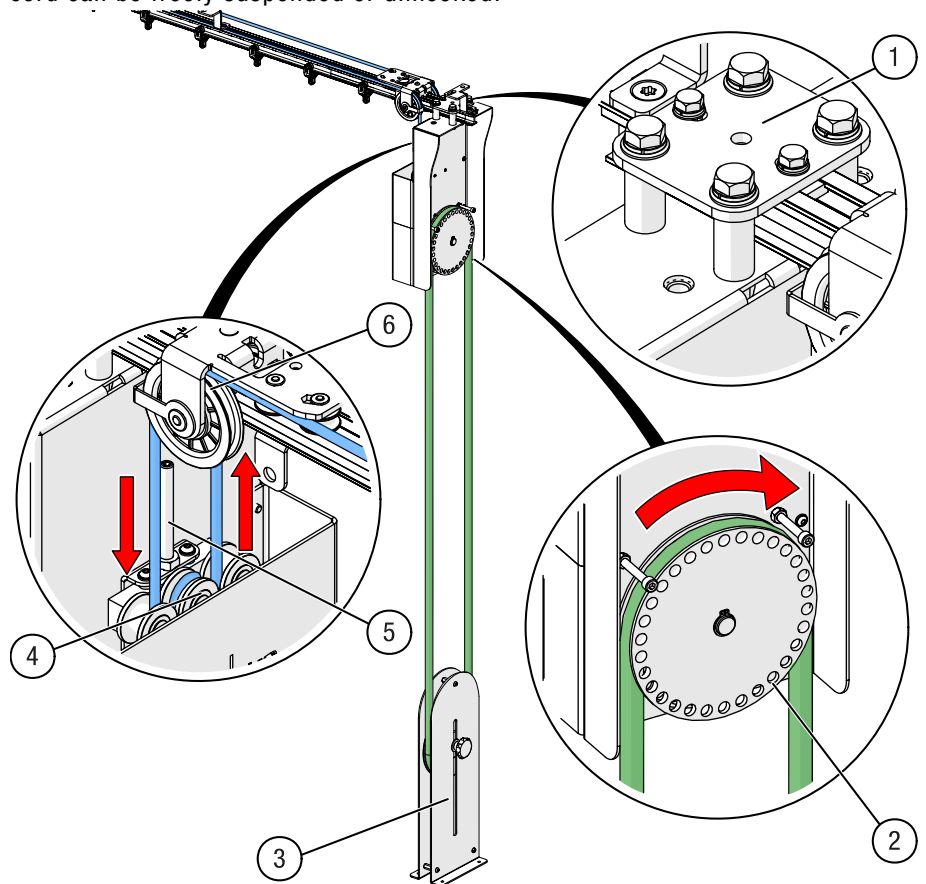

Fig. 26: Manual drive ROPE DRIVE with hemp rope floor pulley and TRUMPF 95 track system



To prevent slippage, sufficient tension on the hemp rope is essential. It is therefore necessary to carefully determine the installation height before ordering.

2.13 Manual drive – HAND-DRIVE

Number and designation:

- 1 Head pulley (downwards)
- 2 Threaded pin
- 3 Clamping unit
- 4 Hand crank
- 5 Star grip for adjustment the translation

A HAND-DRIVE unit (Item no. 31000 07091) enables the operating cord to be driven manually using a hand crank (4/ Fig. 27). The ratio of the hand crank can be changed by loosening the star grip (5/ Fig. 27) and tightening the hand crank in the second mounting position (see *chapter 6.1 HAND-DRIVE* [▶ p. 108]). The polyester operating cord runs in the track layout up to overlap the head pulley (1/ Fig. 27) in the tensioning unit (3/ Fig. 27) with which self-adjusting cord tensioning is achieved. For mounting or maintenance, the threaded pin (2/ Fig. 27) can be completely unscrewed. This way the spring tension is relieved, and the cord can be hooked or unhooked.

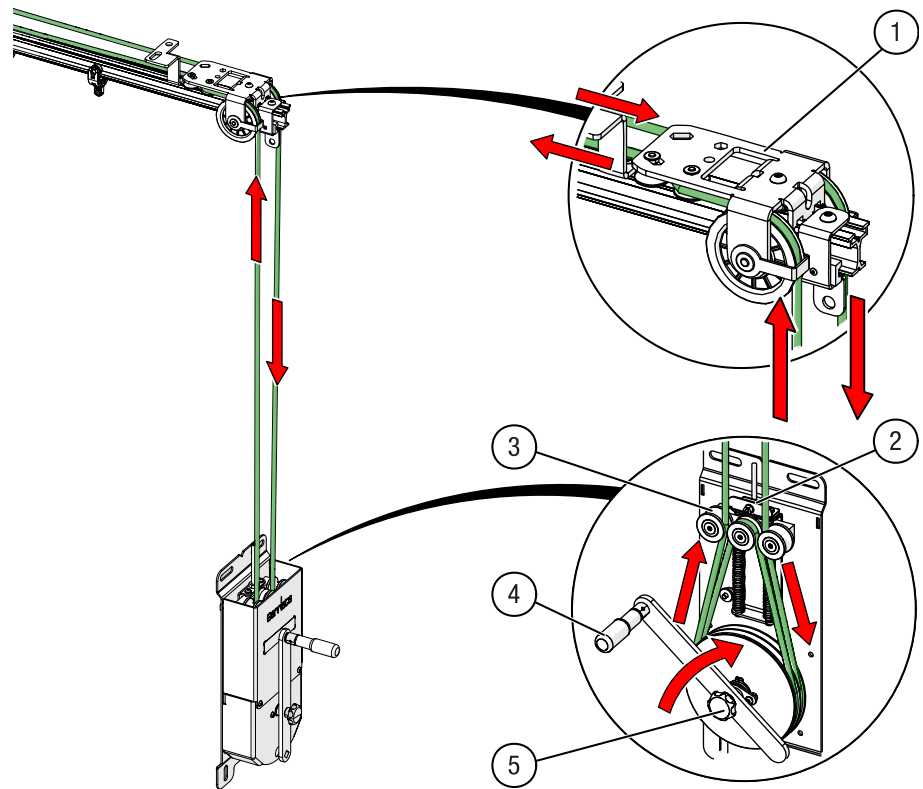

Fig. 27: Manual drive HAND-DRIVE with TRUMPF 95 track system

2.14 Manual drive – Floor pulleys

Number and designation:

- 1 Stirrup floor pulley with foot stirrup
Item no. 31000 07061
- 2 Self tensioning floor pulley
Item no. 31000 07011
- 3 Hemp rope adjustable floor pulley 350
Item no. 31000 07051
- 4 Adjustable floor pulley
180 – Item no. 31000 07071
350 – Item no. 31000 07081
- 5 Floor pulley for weighting sandbag
Item no. 31000 07065
- 6 Hemp rope pulley for weighting sandbag
Item no. 31000 07067

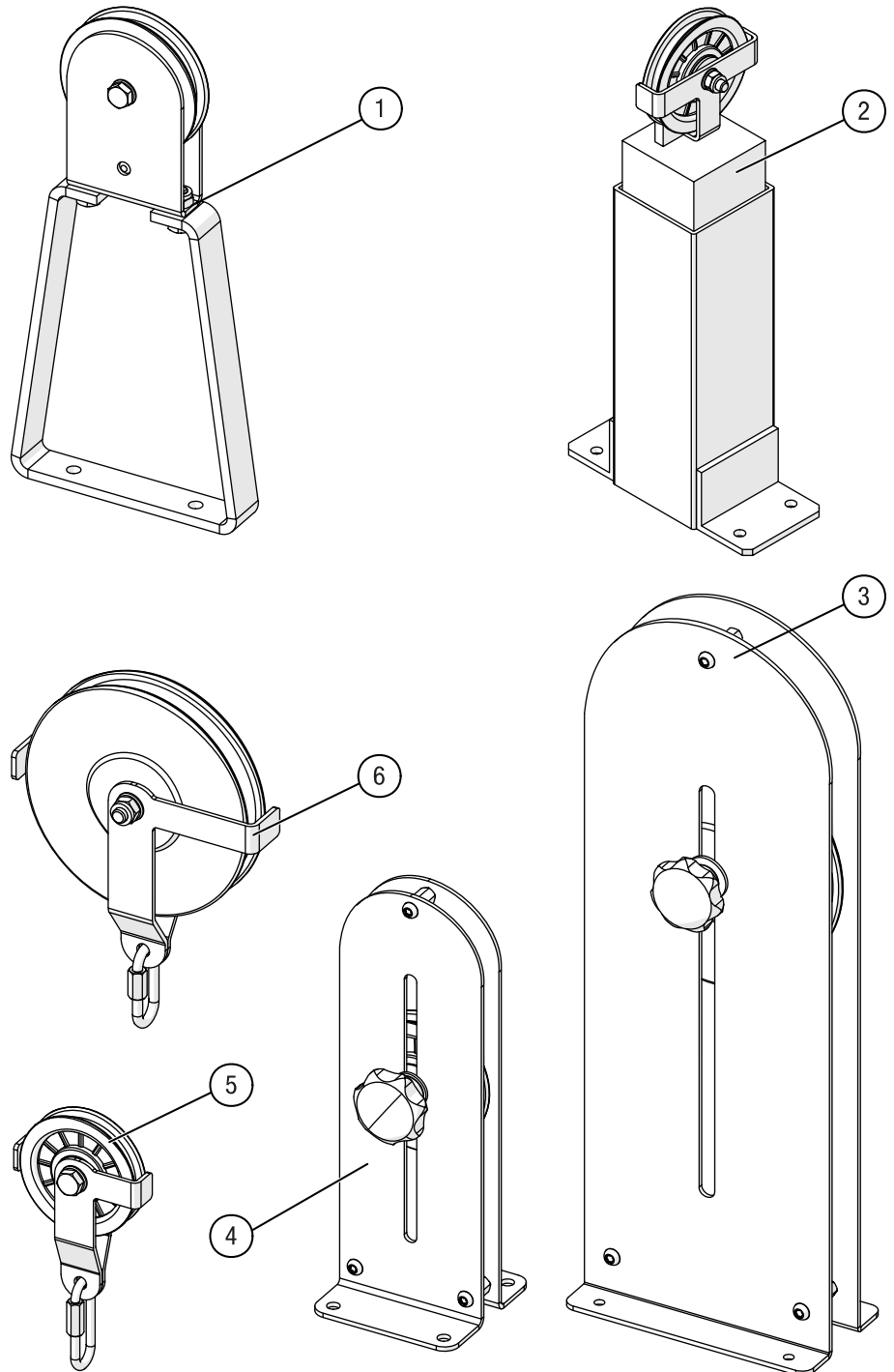

Fig. 28: Manual drive – Floor pulley

3 Technical data

3.1 Ambient conditions

Ambient conditions and operating parameters

Parameters	Value
Permissible ambient temperature	Room temperature
Moisture/wetness	Not suitable for use in damp / wet environments.

Tab. 1: TRUMPF 95 track system – Ambient conditions and application parameters

3.2 Track system

Mechanical data track system

Parameters	Value
Weight	900 g/m (0.3 lbs/ft)
Profile cross-section dimensions	See Tab. 3, Tab. 4 and Tab. 5
Profile length	Max. 6.0 m (approx. 20 ft)
Colour variants	Black, silver, white and desired colour
Load capacity	See Tab. 3, Tab. 4 and Tab. 5
Fastening	Chapter 2.6 Suspension variants [▶ p. 20]
Minimum bending radius (track)	Theatre interior 0.5 m (19.6")

Tab. 2: TRUMPF 95 track system – Mechanical data

3.2.1 Permissible load with standard slot nut

Suspension distance L [m]	Point load F [kg]	Line load q [kg/m]	Total distributed load [kg]	Track profile Cross-section [mm]
2,00 m	25 kg	20 kg/m	40 kg	
1,75 m	33 kg	30 kg/m	53 kg	
1,50 m	44 kg	36 kg/m	54 kg	
1,25 m	49 kg	43 kg/m	54 kg	
1,00 m	49 kg	53 kg/m	53 kg	
0,50 m	49 kg	107 kg/m	54 kg	

Tab. 3: Permissible load – TRUMPF 95 track with standard slot nut

3.2.2 Permissible load with slide-in slot nut

Suspension distance L [m]	Point load F [kg]	Line load q [kg/m]	Total distributed load [kg]	Track profile Cross-section [mm]
2,00 m	25 kg	20 kg/m	40 kg	
1,75 m	33 kg	30 kg/m	53 kg	
1,50 m	44 kg	47 kg/m	71 kg	
1,25 m	64 kg	56 kg/m	70 kg	
1,00 m	64 kg	71 kg/m	71 kg	
0,50 m	64 kg	141 kg/m	71 kg	

Tab. 4: Permissible load – TRUMPF 95 track with slide-in slot nut

3.2.3 Permissible load with heavy-duty (HD) slot nut

Suspension distance L [m]	Point load F [kg]	Line load q [kg/m]	Total distributed load [kg]	Track profile Cross-section [mm]
2,00 m	25 kg	20 kg/m	40 kg	
1,75 m	33 kg	30 kg/m	53 kg	
1,50 m	44 kg	47 kg/m	71 kg	
1,25 m	64 kg	70 kg/m	87 kg	
1,00 m	79 kg	87 kg/m	87 kg	
0,50 m	79 kg	174 kg/m	87 kg	

Tab. 5: Permissible load – TRUMPF 95 track with HD slot nut

3.3 Runners and master runners

Mechanical data

Parameters	Value
Required space in the storage area	See the following illustrations: width measurements of master runners for cord operations may deviate
Overlapping of the curtain parts on the master runner	Master runner with overlap arm (one-sided): approx. 363 mm
Load capacity 2-wheel-runner	10 kg
Load capacity 4-wheel-runner	20 kg
Load capacity 4 × 4 runner	20 kg
Load capacity scenery runner	35 kg
Load capacity swivel pipe	20 kg
Load capacity master runner	35 kg
Distance runner (depending on the track bending radius)	Standard (radius 500 mm): 200 mm

Tab. 6: TRUMPF 95 runners and master runners – Mechanical data

Dimensions – 2-wheel-runner

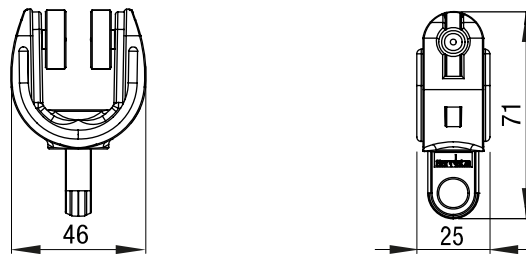

Fig. 29: Dimensions – 2-wheel-runner

Dimensions – 4-wheel-runner

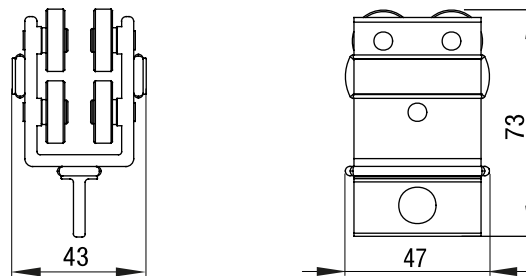

Fig. 30: Dimensions – 4-wheel-runner

Dimensions – 4x4-runner

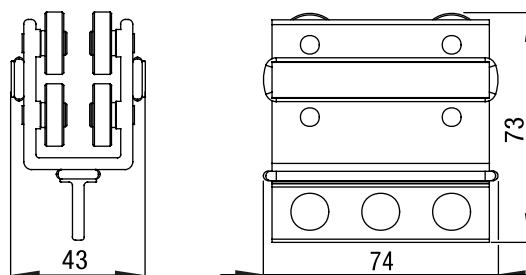

Fig. 31: Dimensions – 4x4-runner

Dimensions – HD master runner

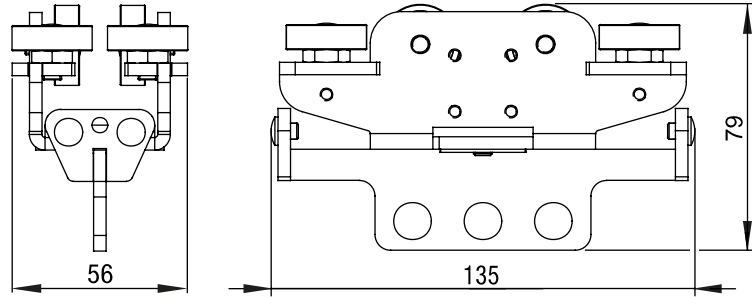

Fig. 32: Dimensions – HD master runner

Dimensions – HD master runner with overlap arm on one side

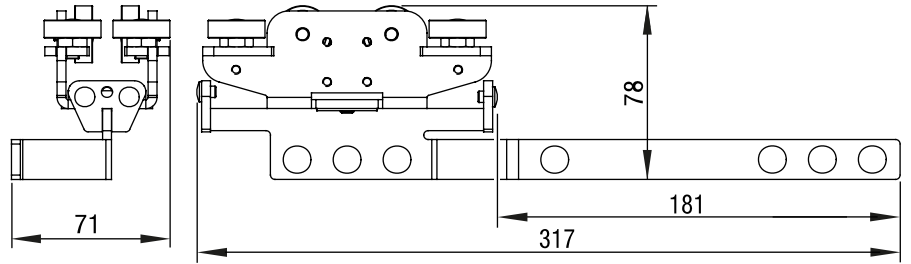

Fig. 33: Dimensions – HD master runner with overlap arm

Dimensions – scenery runner

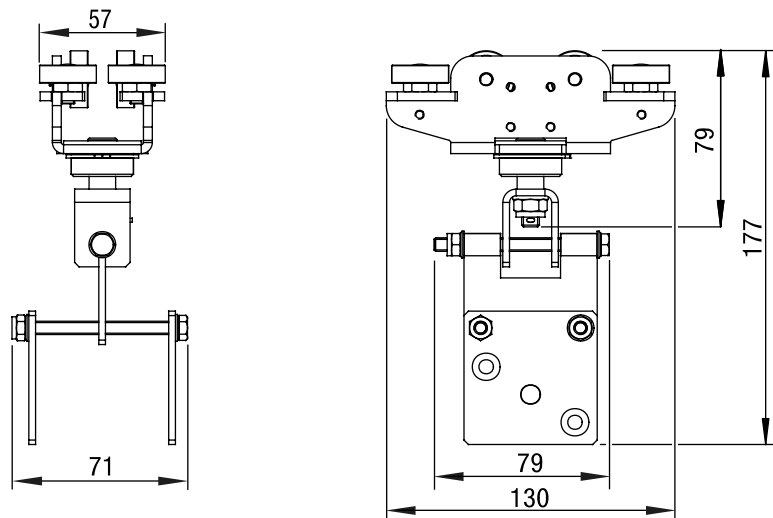

Fig. 34: Dimensions – Scenery runner

Dimensions – swivel pipe 1200 / 1500

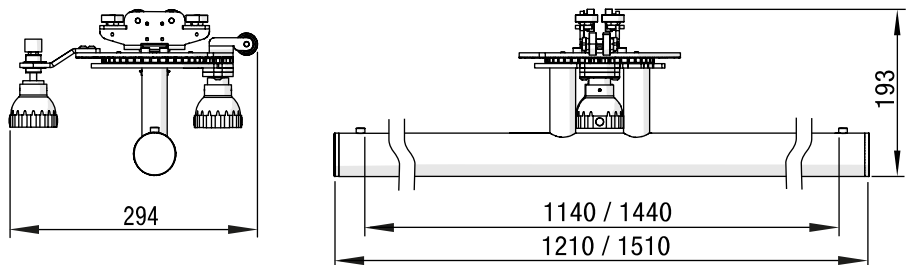

Fig. 35: Dimensions – Swivel pipe 1200 / 1500

3.4 Track switch

3.4.1 Mechanical data

Mechanical data

Parameters	Value
Weight depends on variant	1 to 2 manual – 10.8 kg 1 to 3 manual – 15.1 kg 2 to 3 manual – 16.7 kg 1 to 2 electrical – 12.9 kg 1 to 3 electrical – 17.6 kg 2 to 3 electrical – 19.0 kg
Manual drive	Polyester rope Ø 8 mm
Dimensions	See Fig. 36 and Fig. 37
Load capacity	Track finger: 35 kg
Fastening	Defined Ø 11 mm drill holes on the sheet metal with threaded rods / screw connection

Tab. 7: TRUMPF 95 track switch – Mechanical data

Dimensions – Track switch 1 to 2 manual

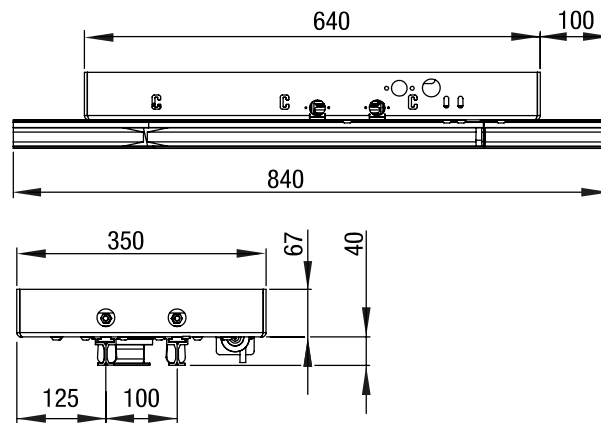

Fig. 36: Dimensions – Track switch 1 to 2

Dimensions – track switch
2 on 3 and 1 on 3, manually

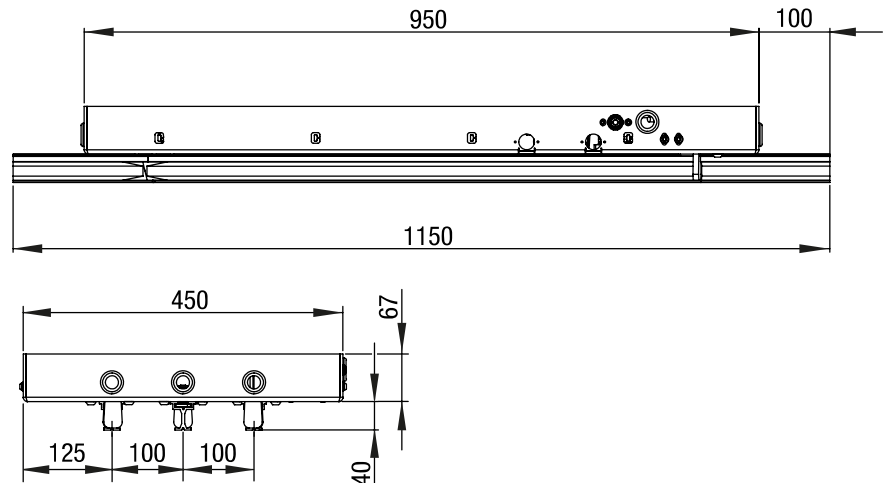

Fig. 37: Dimensions – Track switch 2 on 3 and 1 on 3

3.4.2 Electrical data

Electrical data

Parameters	Value
Electrical data (power supply)	230 V AC, 50 Hz
Electrical drive	Motor 24 V DC with spindle gear
Insulation class	IP20
Electrical connection	Clamping to G-FRAME 54 points control unit by specialised personnel Item no. 31900 05031
Connection cable (exclusive)	Item no. 31900 05111 – 15 m Item no. 31900 05112 – per running meter
Operating mode / motor duty cycle (short-time operation, constant load)	S2 – 10 min (overload protection)
Rated motor current (A)	4
Maximum motor current (A)	22
Rated motor power (W)	11.5

Tab. 8: Electrical data – TRUMPF 95 track switch

3.4.3 G-FRAME 54 track switch control unit

Please refer to your order documents for the product variant you have purchased. Circuit diagrams and data may differ.

Mechanical data

Parameters	Value
Weight	16.5 kg
Dimensions	See Fig. 38 and Fig. 39

Tab. 9: Mechanical data – G-Frame 54

Dimensions: Front view

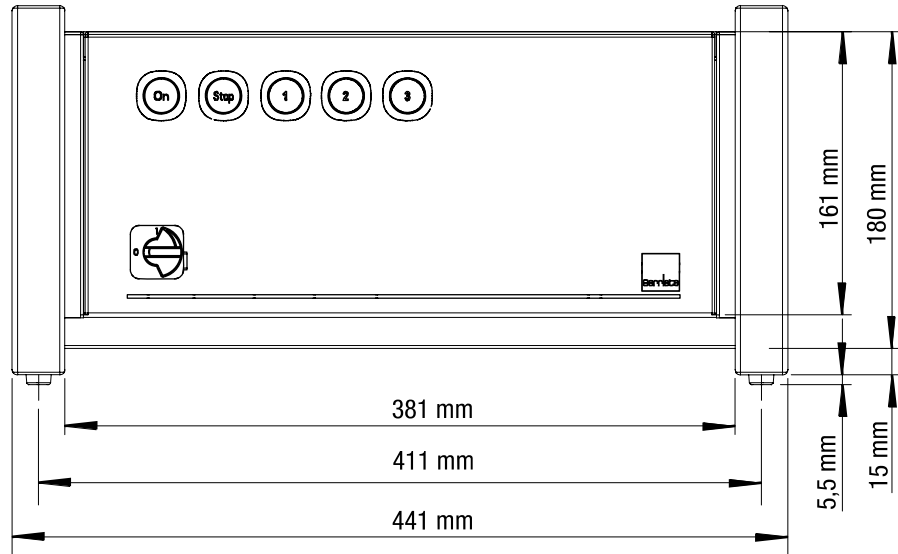

Fig. 38: Front view – G-FRAME 54

Dimensions: Side view

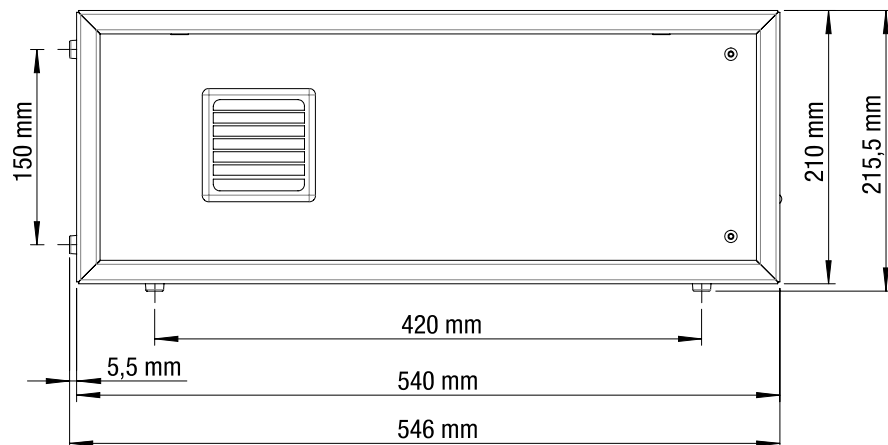

Fig. 39: Side view – G-FRAME 54 control system

Electrical data

Parameters	Value
Electrical data	230 V AC, 8 A, 50 Hz 120 V AC, 15 A, 60 Hz
Insulation class	IP40
Electrical connection	IEC plug

Tab. 10: Electrical data – G-FRAME 54

4 Transport

4.1 Transport



- Check the packaging for any transport damage and file a complaint immediately if the product is damaged.
- Check the delivery note and ensure that the delivery is complete.
- Complain about any missing or damaged parts immediately.
- If necessary, keep the original packaging for later storage.
- Follow the safety instructions in *the chapter 10 Safety* [► p. 116].
- Conduct a visual inspection after each transport and periodically during the life cycle (see *chapter 7 Maintenance and servicing* [► p. 112]).



WARNING

Personal injury and property damage due to incorrect or improper transport

Incorrect or improper transport can cause transported goods to fall and result in personal injury or material damage.

- Personal protective equipment compulsory (safety shoes, gloves).
 - Use suitable aids or carrying devices (e.g. lifting devices or carrying straps).
-

5 Assembly

- Follow the safety instructions in *chapter 10 Safety* [▶ p. 116].
- Follow the maximum loads and suspension distances from *chapter 3.2 Track system* [▶ p. 32]).
- Select the slot nuts used according to the permissible loads (see tables in *chapter 3.2 Track system* [▶ p. 32]).
- Follow the installation instructions in *the chapter 5.1 Mounting instructions / track system* [▶ p. 41].
- Plan the required mounting material according to your ceiling or wall construction.
- The screw head drives may vary due to internal processes (TORX® / hexagon socket).
- Screw tightening torques can be found in the assembly steps or *at chapter 12.1 Screw tightening torques* [▶ p. 121].
- Specifications for screw drives may vary technically.
- Always conduct the installation steps, such as ceiling installation of the pre-assembled track system, in pairs.
- Use end stops to secure free track ends and interruptions.
- Ensure that assembly aids are securely positioned.
- Protect the curtain from dirt by surrounding construction work by covering it with foil when having interruptions in the assembly process.
- Before the assembly of the runners, make sure that the tracks are free of drilling dust and dirt.
- If you encounter problems during the assembly that cannot be solved by yourself, please contact us.



WARNING

Personal injury and property damage due to falling objects

If the load-bearing capacity of the ceiling structure or individual components is too low, objects may come loose and fall, resulting in death, severe injury or damage to property.

- Consider the maximum load-bearing capacities of the overall system and individual components.
- Only install the system on a sufficiently stable substrate or substructure.
- Do not make any changes, additions, or set changes to the product unless these have been authorised in writing by Gerriets.
- Ensure that loads to be fastened are also secured against falling during assembly.
- Always assemble the screw connections of the parts using the specific assembly instructions and torques.
- Always insert securing elements such as rings, clips, and pins correctly and check their effectiveness.
- If you have any concerns about this product, please contact Gerriets GmbH.

5.1 Mounting instructions / track system

- ➔ Attach the suspension points at the maximum distance calculated in the order.
- ➔ Always attach a suspension in the vicinity of head pulleys and/or drives as well as other devices subject to higher loads.
- ➔ Ensure that the surface for the assembly of the suspension points is as level as possible. Use aids such as cross and line lasers to determine the evenness. Deviations can be levelled out with lining sheets.



The following assembly steps show the standard slot nut applicable to the section. A different slot nut may be provided depending on the design and requirements.

Distance of the suspensions to the joint

- ➔ Attach a suspension point on one side at a maximum distance of 15 cm from the centre of the suspension to the joint (see Fig. 40).

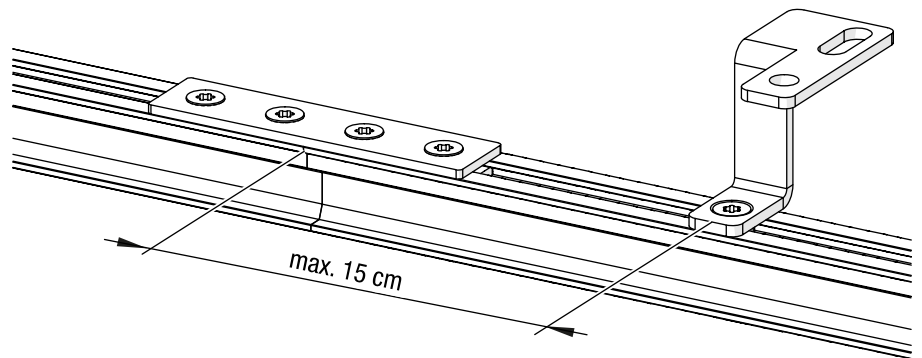

Fig. 40: Suspension distance to the joint (top cord operation as an example)

Distance of the suspensions to the end of the track

- ➔ Attach a suspension point at a maximum distance of 20 cm from the centre of the suspension to the end of the track (see Fig. 41).

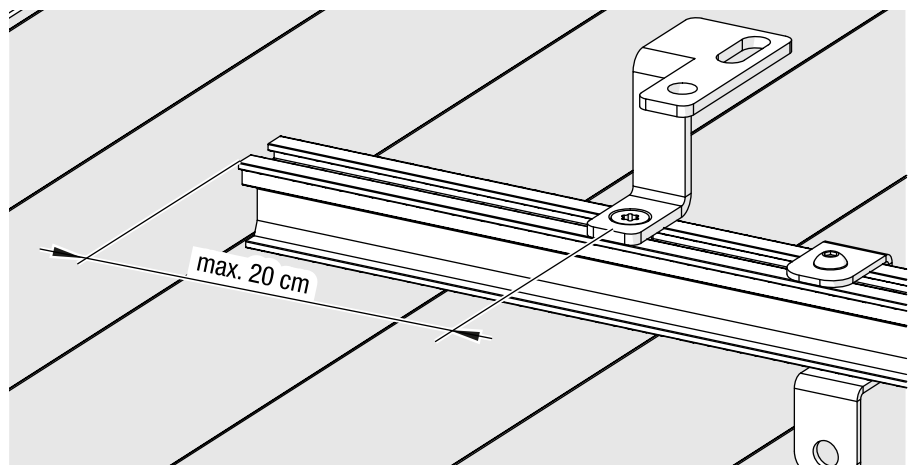

Fig. 41: Suspension distance to the end of the track (top cord operation as example)

5.2 Installing the track system

5.2.1 Track splice

Materials / tools required

Quantity	Materials / Tools
1	Hammer (not included)
1	Pipe wrench (not included)
1	TORX®-key T40 (not included)
1	TRUMPF 95 track splice (including two connecting pins) – Item no. 31150 00061
Alternative:	TRUMPF/TRUMPF 95 connecting pins Touring, set of 10 – Item no. 31000 09117
2	TRUMPF 95 track parts

Tab. 11: Materials and tools required for assembly of the track splices



Use the TRUMPF/TRUMPF 95 Touring connecting pins made from stainless steel for frequent assembly and disassembly. They can be reused and there is no need pressing them together with pliers as in step 1) because they can be inserted easily.

Fitting the connecting pins

1. Press the connecting pins together slightly conically with a pipe wrench and insert them into the centring holes provided in the profile (see Fig. 42).

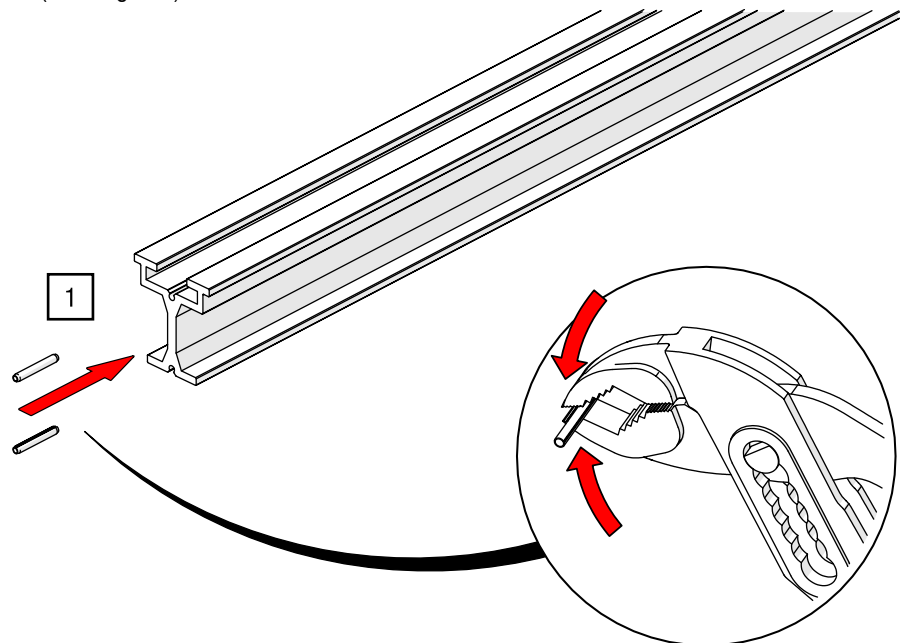

Fig. 42: Track splice – Insert connecting pin into track section

2. Carefully hammer the connecting pins halfway into the track (see Fig. 43).

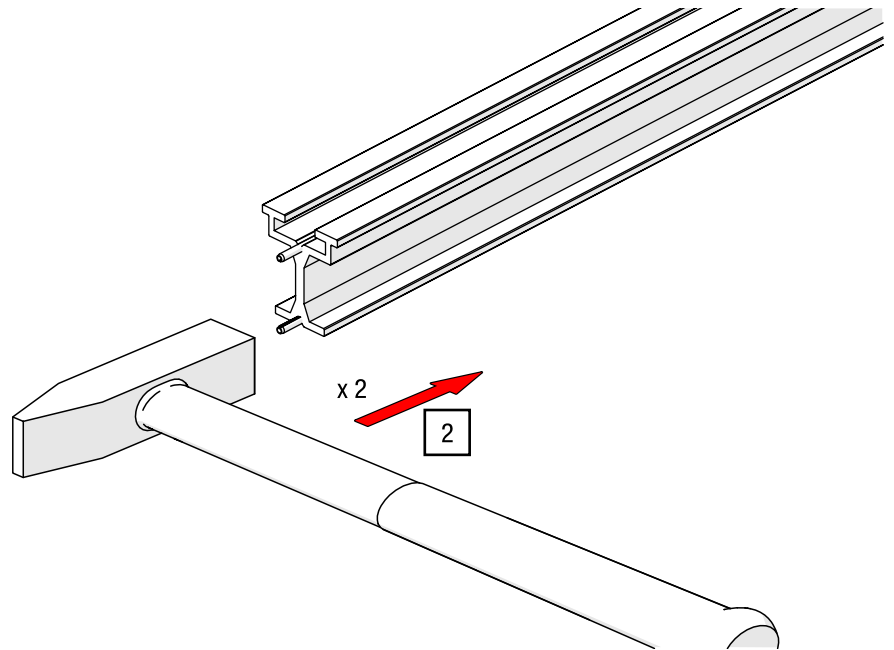

Fig. 43: Track splice – Hammer in the connecting pin

Inserting track splices

3. Push the pre-assembled track splice completely into the top groove of the track section (see Fig. 44).

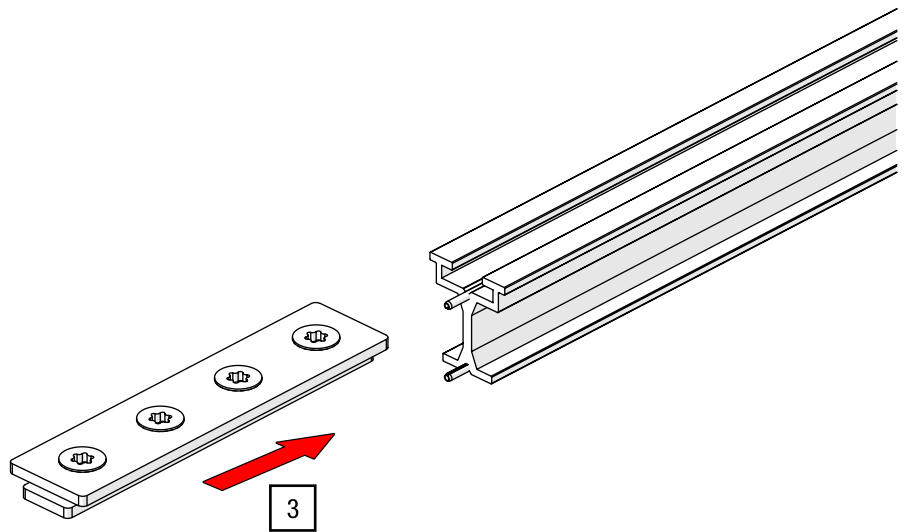

Fig. 44: Track splice – Insert into track

Connecting track sections

4. Place the second track section on the connecting pins and position it flush with the first track section (see Fig. 45).



Carefully press the connecting pins together slightly with a pipe wrench before attaching them.

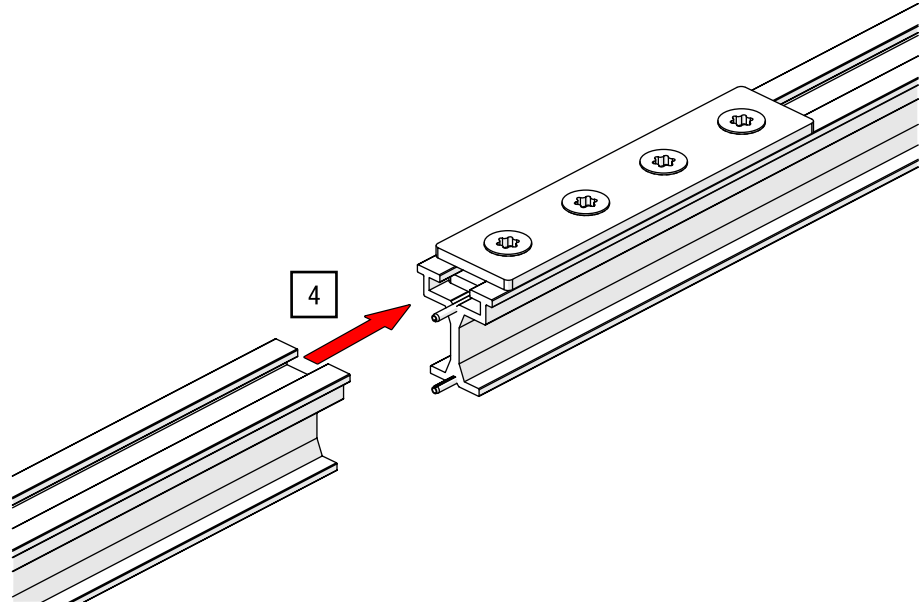

Fig. 45: Track splices – Plug the track parts together

5. Move the track splice to the centre of the connected track parts (see Fig. 46).

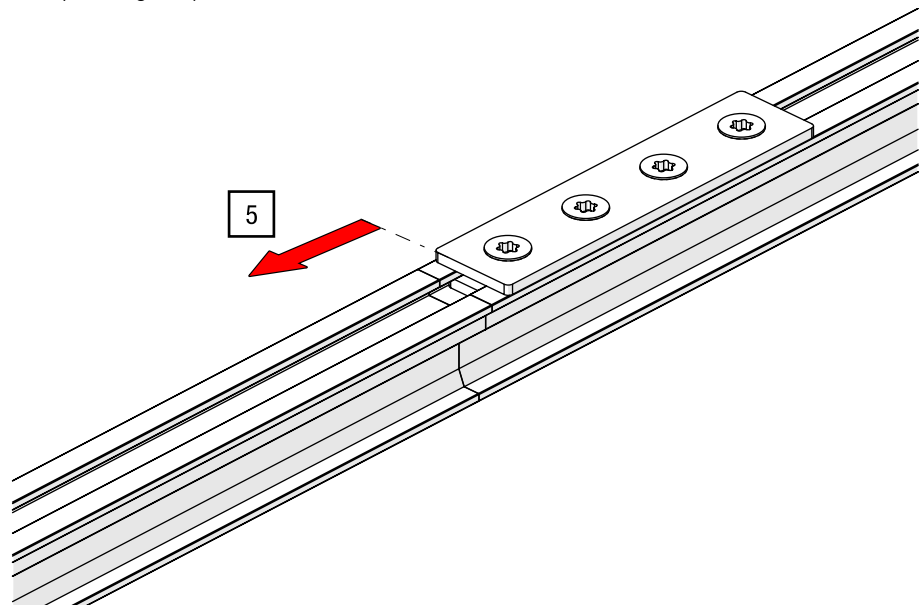

Fig. 46: Track splice – Position in the centre

Fastening track splice

6. Tighten the four M8 countersunk screws from the inside to the outside using a TORX®-key T40 and a torque of 27 Nm (see Fig. 47).

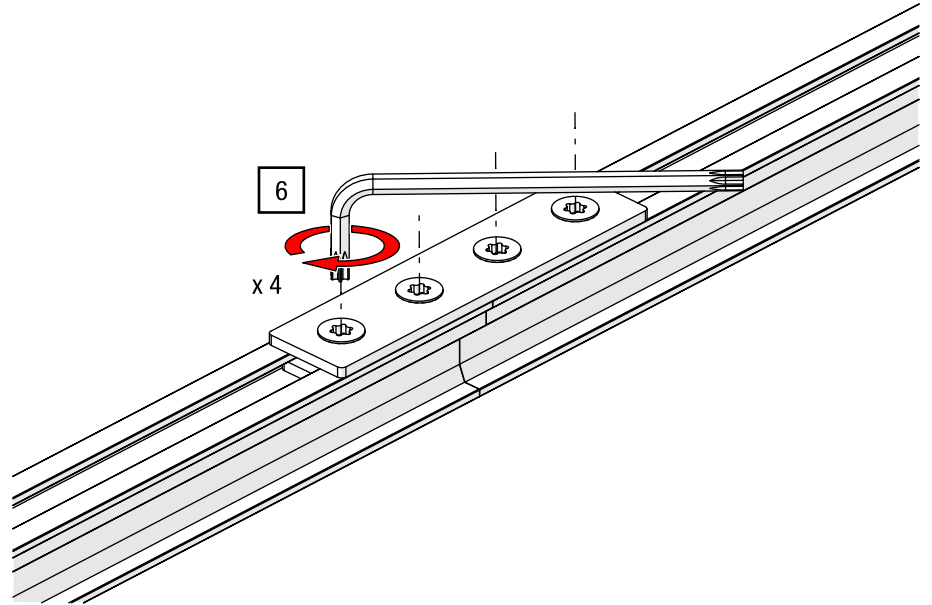

Fig. 47: Track splice – Tighten countersunk screws

5.2.2 Double track suspension bracket (2-track)

Materials / tools required

Quantity	Materials / Tools
According to order	Double track suspension bracket Item no. 31150 08021 Consisting of: <ul style="list-style-type: none"> • 1× Adapter plate • 2× standard slot nut • 2 × countersunk head screw M8 TORX®
1	TORX®-key T40 (not included)

Tab. 12: Double track suspension bracket (double track) – Materials and tools required for assembly



The adapter plate has a through hole for M12 for fastening to a substructure with a suitable fastener.

The G-CLAMP 48/60 – Item no. 31000 08091 (see accessories) can be used to attach the track construction to a truss, for example.

Assembly in orientation levelling plate

1. Insert the slot nuts into the track profile and screw the adapter plate on the profile in orientation of a levelling plate using a TORX®-key T40 and 27 Nm (see Fig. 48).

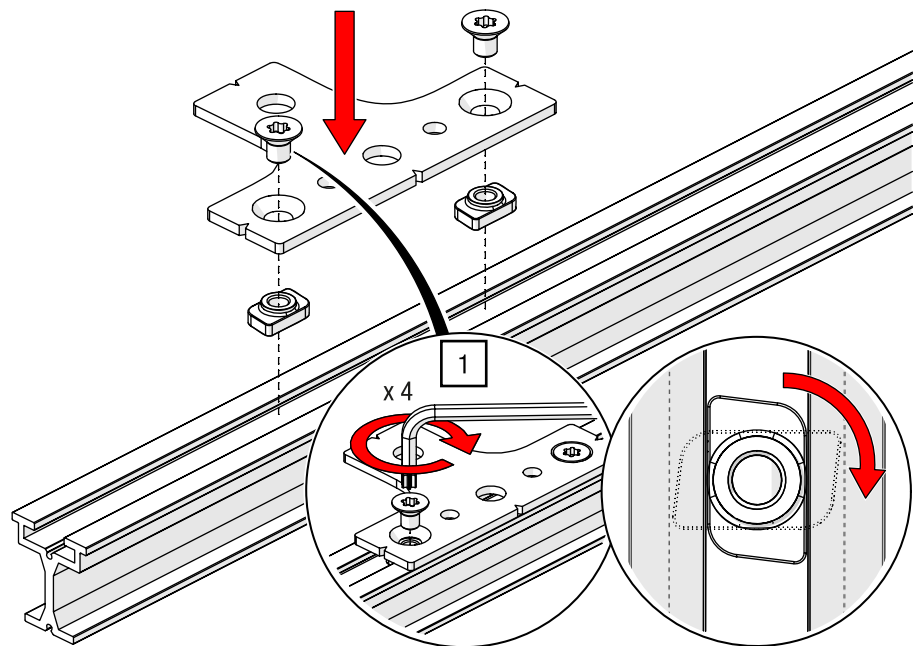

Fig. 48: Double track suspension bracket – Mount in direction of levelling plate

Assembly in overlap orientation
(parallel connection and
suspension of tracks)

1. Place a slot nut in one of the two track parts and fasten the adapter plate transversely orientated as a connecting plate using a TORX®-key T40 and 27 Nm (see Fig. 49).

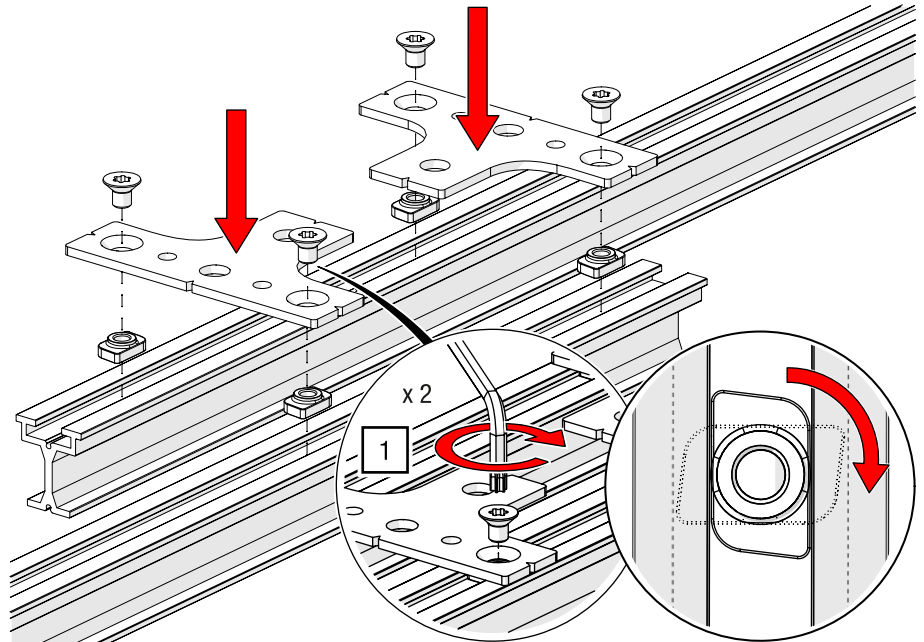

Fig. 49: Double track suspension bracket (double track) – Mount at right angle to the track (overlap)

5.2.3 End stop HD

Materials / tools required

Quantity	Materials / Tools
1	TRUMPF 95/STUDIO end stop HD Item no. 31000 0094X
1	Allen key AF 3 (not included)

Tab. 13: Materials and tools required for assembly of the HD end stop

1. Slide the end stop HD onto one end of the track (see Fig. 50).

Assembly

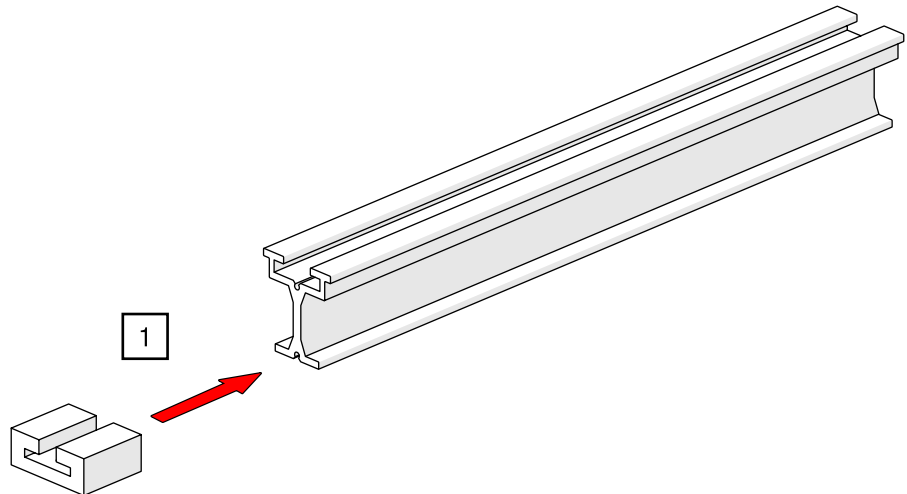

Fig. 50: End stop HD – Push the end stop onto the track

Fixing the HD end stop

2. Tighten the M6 grub screws to 11 Nm using an Allen key AF 3 (see Fig. 51).

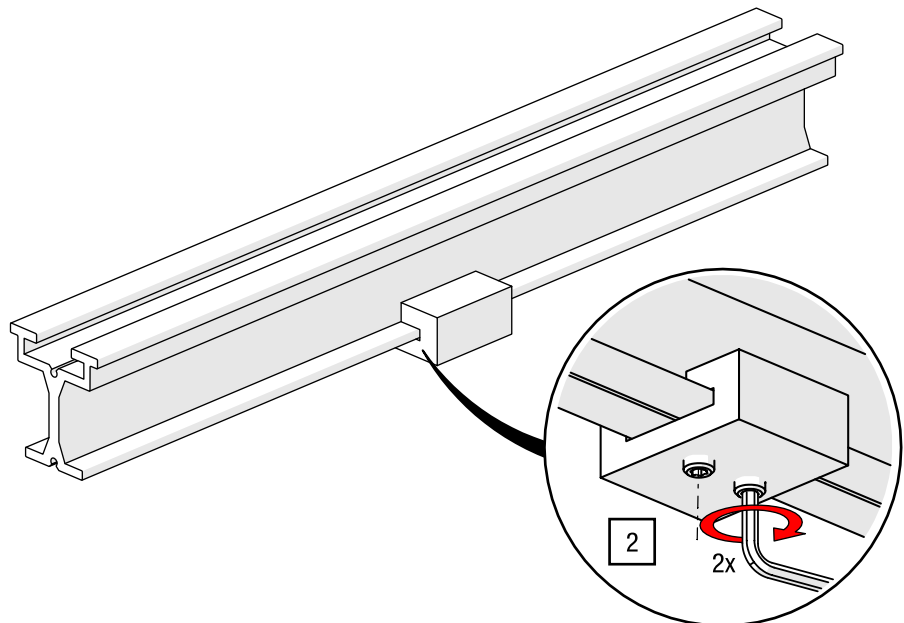

Fig. 51: TRUMPF 95/STUDIO end stop HD – Tighten grub screws

5.2.4 TRUMPF 95 end stop

Materials / tools required

Quantity	Materials / Tools
1	TRUMPF 95 end stop – Item no. 31150 00981
1	Allen key AF 5 (not included)

Tab. 14: Materials and tools required for assembly of the TRUMPF 95 end stop

1. Hang the pre-assembled end stop in the track profile and tighten the screw with slot nut using an Allen key AF 5 and 27 Nm (see Fig. 52).

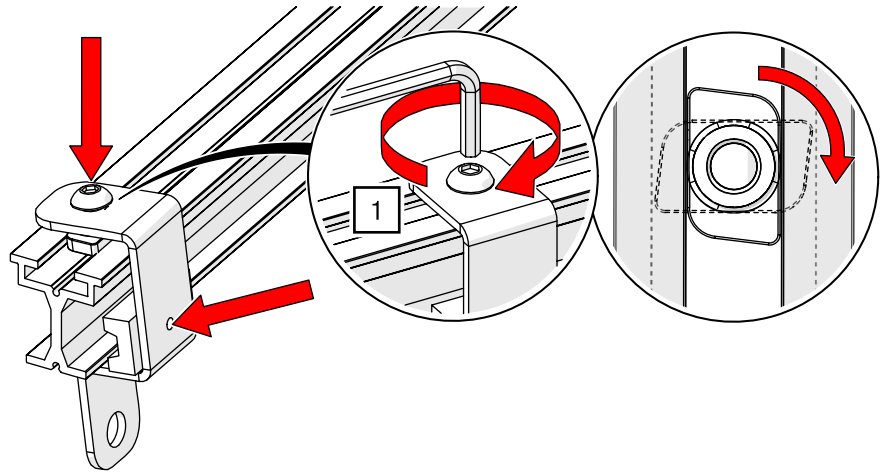

Fig. 52: TRUMPF 95 end stop – Mounting the end stop

5.3 Installing suspensions

5.3.1 Central mounting G-TWIST II – Ceiling mounting / walk-along track

Materials / tools required

Quantity	Materials / Tools
Corresponding number of suspensions	Mounting material suitable for the substrate: <ul style="list-style-type: none"> • Concrete ceiling: e.g. drive-in anchor E M6, countersunk screw M6× 16 (DIN EN ISO 10642) • Wooden ceiling: e.g. SPAX 5× 40 • Plasterboard: e.g. HTB M5 tilting dowel
1	Suitable tools, e.g. drill (not included)
Quantity according to order	Central mounting G-TWIST II Item no. 31150 0811X

Tab. 15: Materials / tools required for direct ceiling installation of the G-TWIST II

Installing G-TWIST II on a concrete ceiling

1. Screw the G-TWIST II central mounting to the ceiling using the appropriate mounting material for the surface (assembly according to the manufacturer's instructions; example concrete ceiling – see Fig. 53).



Make sure that the surface for the assembly of the suspension points is as levelled as possible. Use aids such as cross and line lasers to determine the alignment. Deviations in evenness can be levelled out with lining sheets.

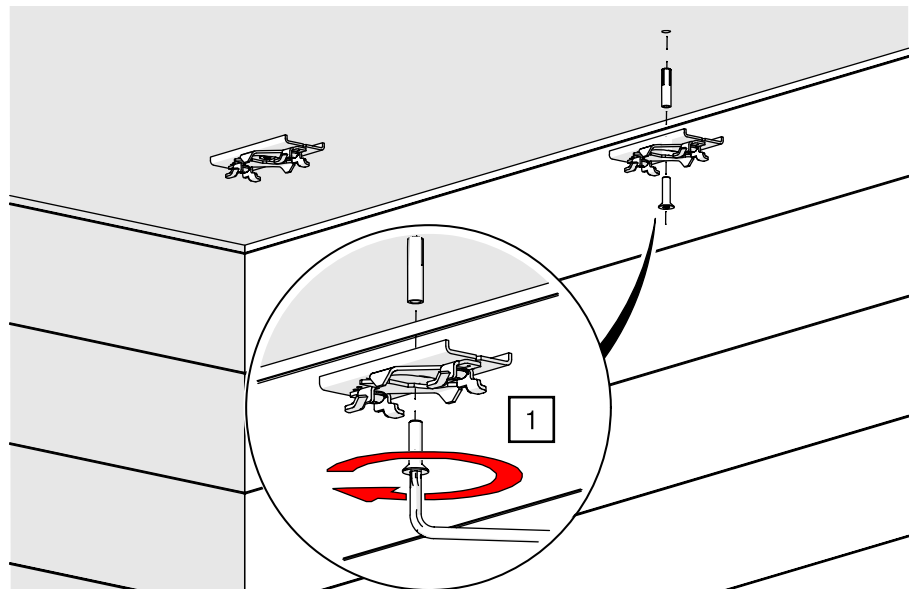

Fig. 53: Ceiling installation – Screwing the G-TWIST II into the ceiling

- G-TWIST II Locking position 1 → 2 2. Lift the track and lock the G-TWIST II into the first locking point (see Fig. 54).

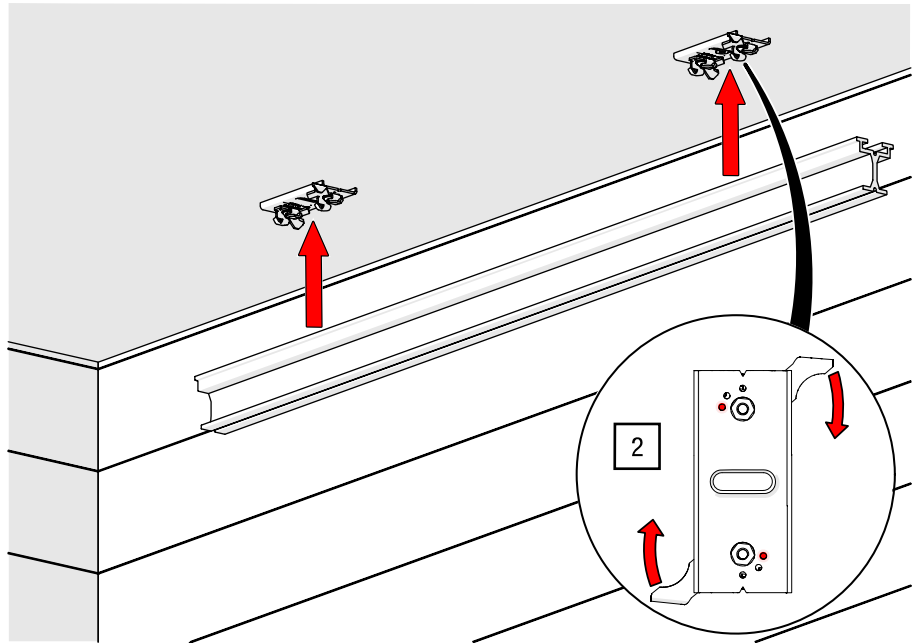

Fig. 54: Ceiling mounting – Fixing the track to the G-TWIST II



The track is now secured vertically and can be moved slightly horizontally.

- G-TWIST II latching position 2 → 3 3. Position the track and then lock it in the third locking position (see Fig. 55 and Fig. 56).

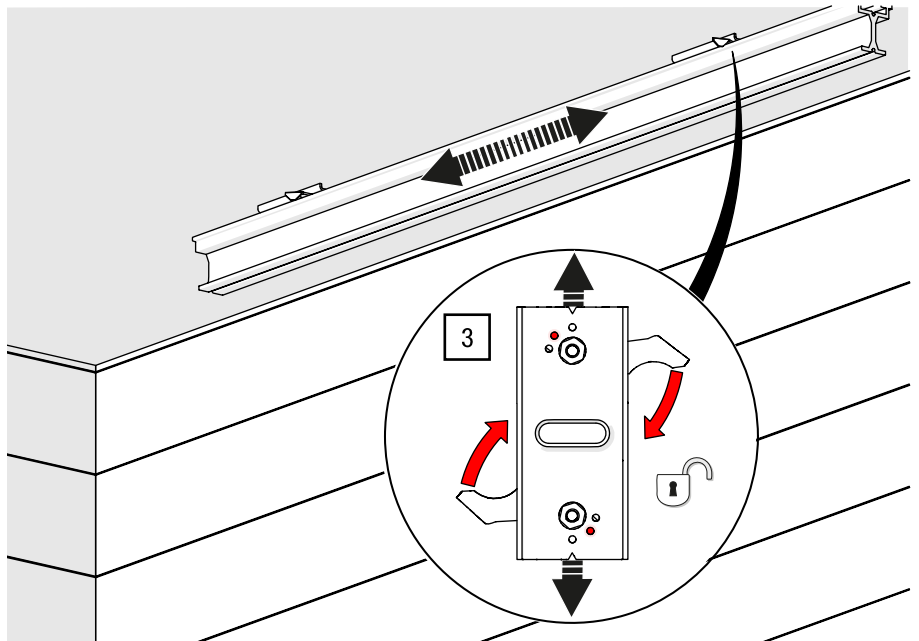

Fig. 55: Ceiling mounting – G-TWIST II in latching position 2

✓ The track is now locked to the ceiling (see Fig. 56).

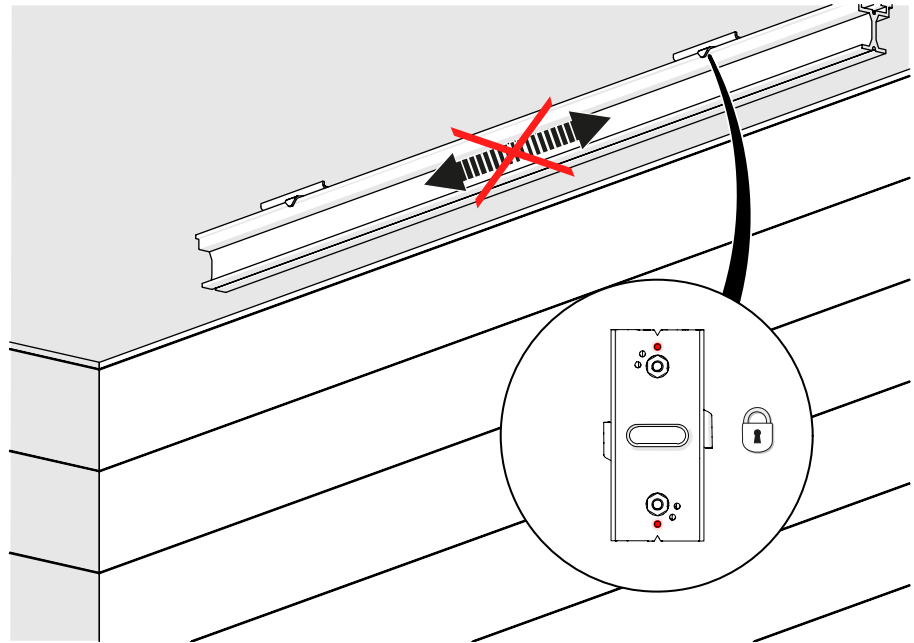

Fig. 56: G-TWIST II in latching position 3 (closed)

5.3.2 Hook clamp G-CLAMP direct – Walk-along track

Materials / tools required

Quantity	Materials / Tools
Corresponding number of suspensions	Hook clamp TRUMPF 95 G-CLAMP 48/60 with fasteners and slot nut for direct track mounting Item no. 31150 08091
Quantity according to order	TRUMPF 95 track section
1	TORX®-key T40 (not included)

Tab. 16: G-CLAMP direct – Materials and tools required for assembly

Mount G-CLAMP directly

1. Slide the slot nut into the profile (see Fig. 57).

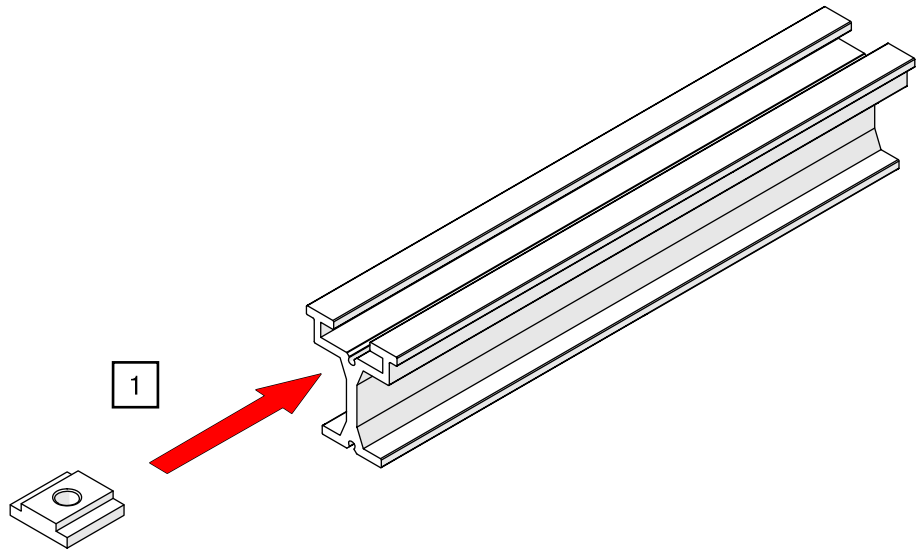

Fig. 57: Slide-in slot nut

Assembly material for step2:
 1 × pan head screw TORX® M8
 1 × washer 8
 1 × reducing sleeve
 1 × slot nut

2. Screw the G-CLAMP hook to the slot nut on the track profile using a TORX®-key T40 and 27 Nm (see Fig. 58).

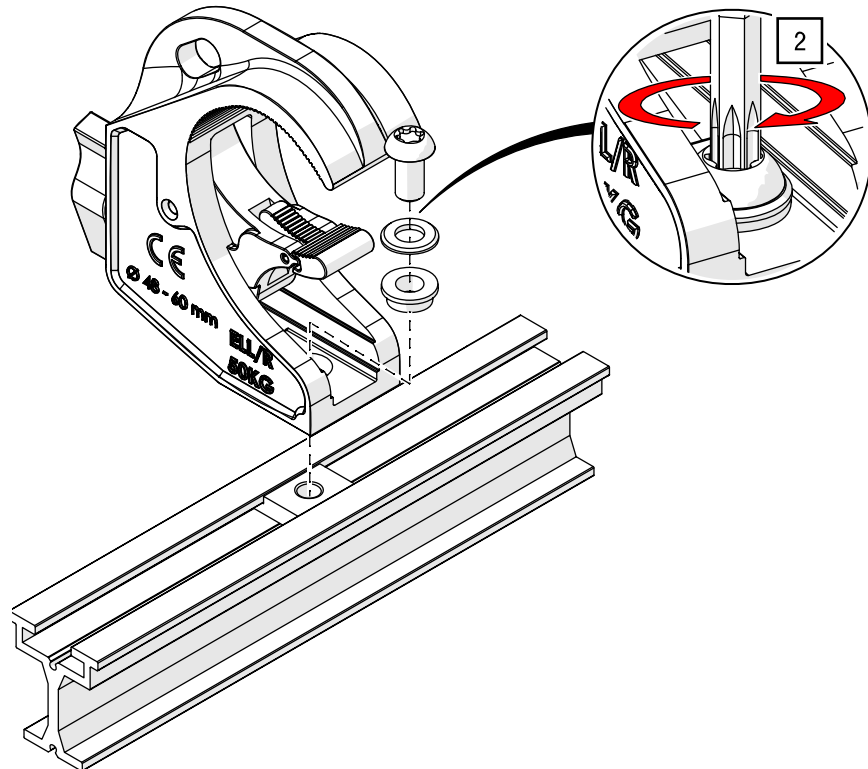

Fig. 58: G-CLAMP direct – Assembly with slot nut

3. Use the wing screw to turn the G-CLAMP hook until it fits over the pipe of the on-site support structure and position it on the on-site support structure (see Fig. 59).

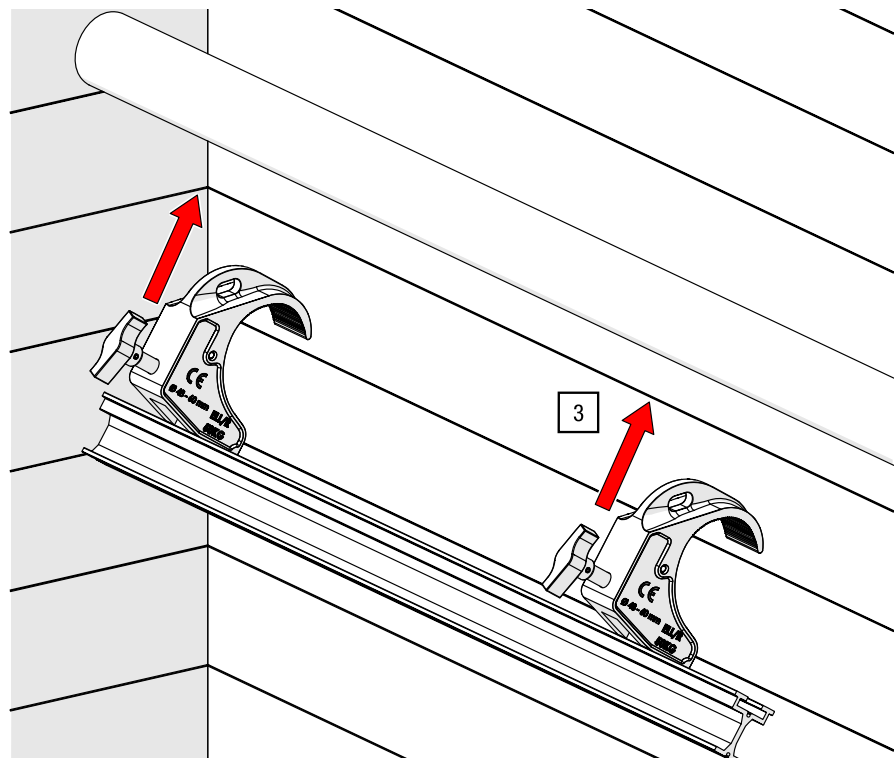

Fig. 59: G-CLAMP direct – Positioning on the pipe

4. Tighten the wing screw hand-tight (see Fig. 60).

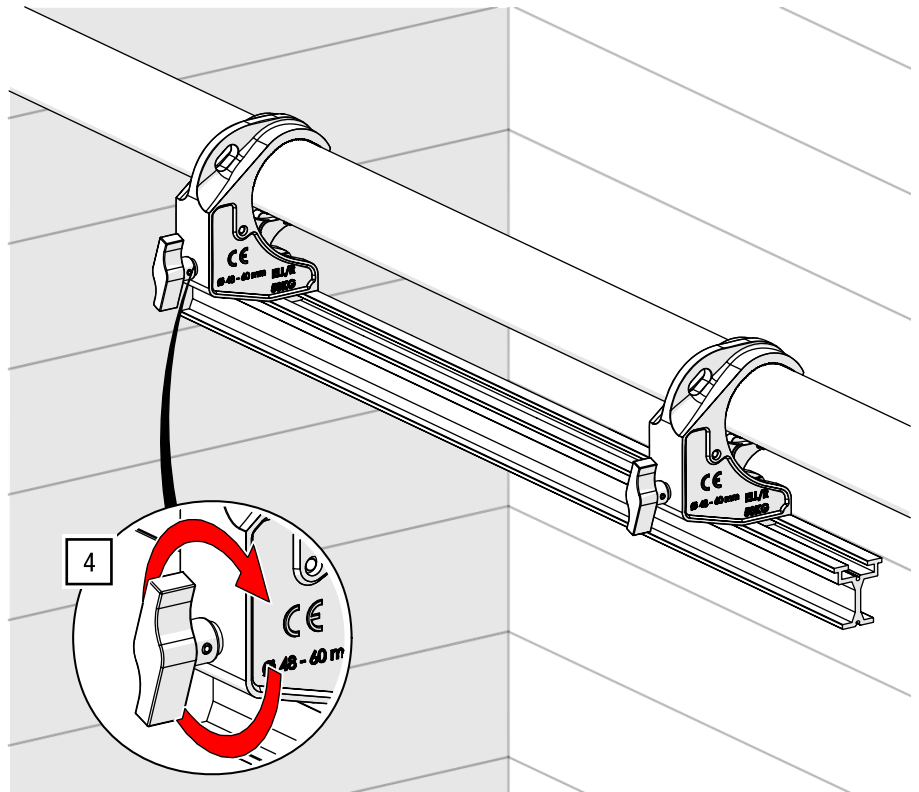

Fig. 60: G-CLAMP direct – Attach to pipe

5.3.3 Ceiling suspension – Ceiling mounting

Materials / tools required

Quantity	Materials / Tools
Corresponding number of suspensions	Mounting material suitable for the substrate: <ul style="list-style-type: none"> • Concrete ceiling: e.g. drive-in anchor E M8 × 40, hexagon head screw M8 × 25 (ISO 4017) • Wooden ceiling / plasterboard according to substrate
1	Suitable tools, e.g. drill and open-end wrench (not included)
Quantity according to order	TRUMPF 95 suspensions for corresponding cord guide variant
1 (double top cord operation, side cord operation)	TORX®-key T40 (not included)
1 (top cord operation)	Allen key AF 5

Tab. 17: Materials / tools required for direct ceiling installation of the suspension



Make sure that the surface for the assembly of the suspension points is as level as possible. Use aids such as cross and line lasers to determine the alignment. Deviations in the evenness of the ceiling can be levelled out with lining sheets.

Install suspension for cord operations on concrete ceiling

1. Screw the suspension for the cord operation to the ceiling using mounting material suitable for the substrate (assembly according to manufacturer's instructions; example concrete ceiling – see Fig. 61).



Always orientate the ceiling suspension for the top cord operation with the bend against the cord clamp so that the master runner can move freely (see also infographics in *chapter 5.4.2 Top cord operation* [► p. 72]).

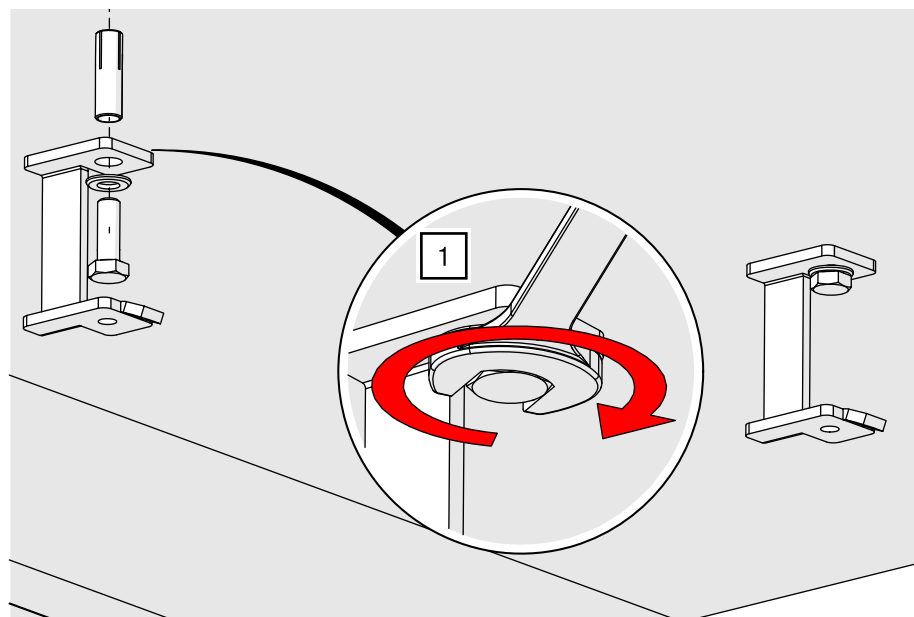

Fig. 61: Suspension for (double top) cord operation – Mount on ceiling

Assembly material for step 2:

Double top cord operation / side cord operation:

1 × pan head screw TORX® M8

1 × spring washer D8

1 × washer 8 ISO 7089

1 × standard slot nut

Top cord operation:

1 × countersunk screw hexagon socket M8 × 12 – ISO 10642

1 × standard slot nut

2. Place the slot nut in the TRUMPF 95 track profile and fix the track to the suspension using a TORX®-key T40 (top cord operation – Allen key AF 5) and 27 Nm (see Fig. 62).

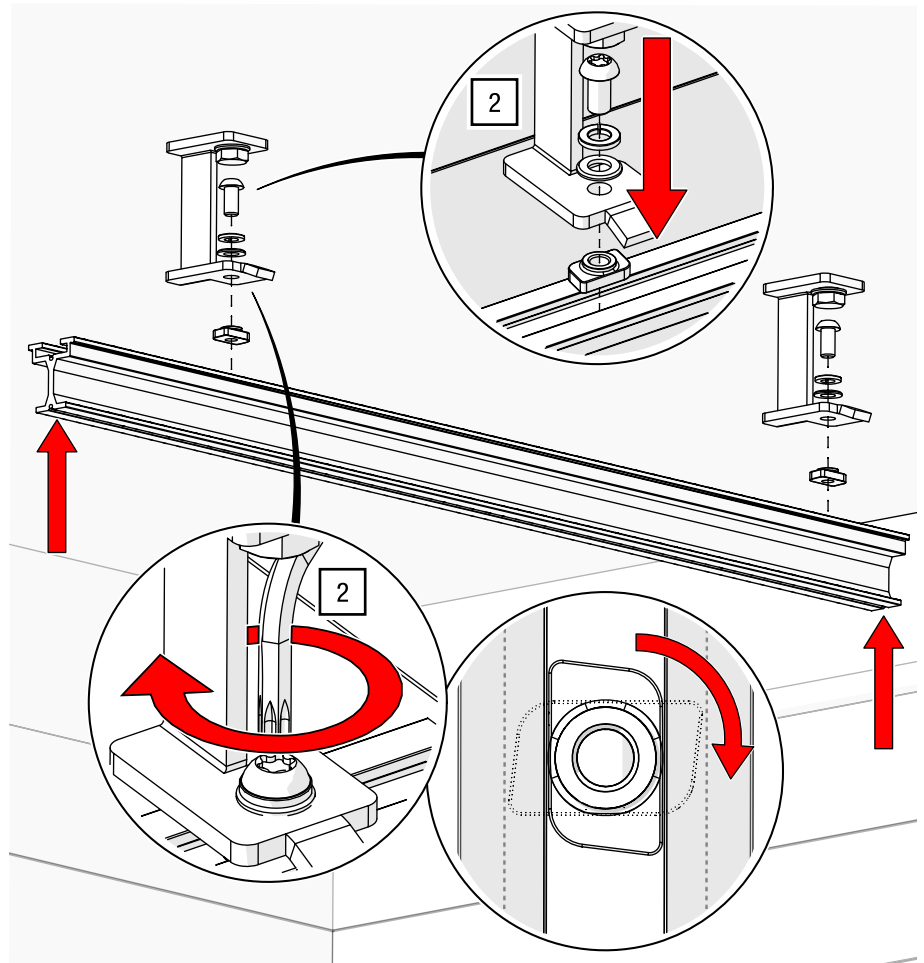

Fig. 62: Suspension for cord operation – Screw on the track

5.3.4 Hook clamp G-CLAMP – Cord operation

Materials / tools required

Quantity	Materials / Tools
Corresponding number of suspensions	G-CLAMP 48/60, direct, incl. fasteners for suspension mounting Item no. 31000 08091 Consisting of: <ul style="list-style-type: none"> • 1 × G-CLAMP • 1 × pan-head screw M12 with socket • 1 × nut M12 • 1 × washer D12
Quantity according to order	TRUMPF 95 track parts
Number and type according to order	Suspension according to the cord guide type with fasteners
1	TORX®-key T40 (not included)

Tab. 1: G-CLAMP – Materials and tools required for assembly

Assembly

1. Mount the sheet metal for suspension to the track using the slot nut and TORX®-key T40 (see Fig. 63).

Assembly material for step 1:

1 × countersunk screw

with TORX® M8

1 × standard slot nut

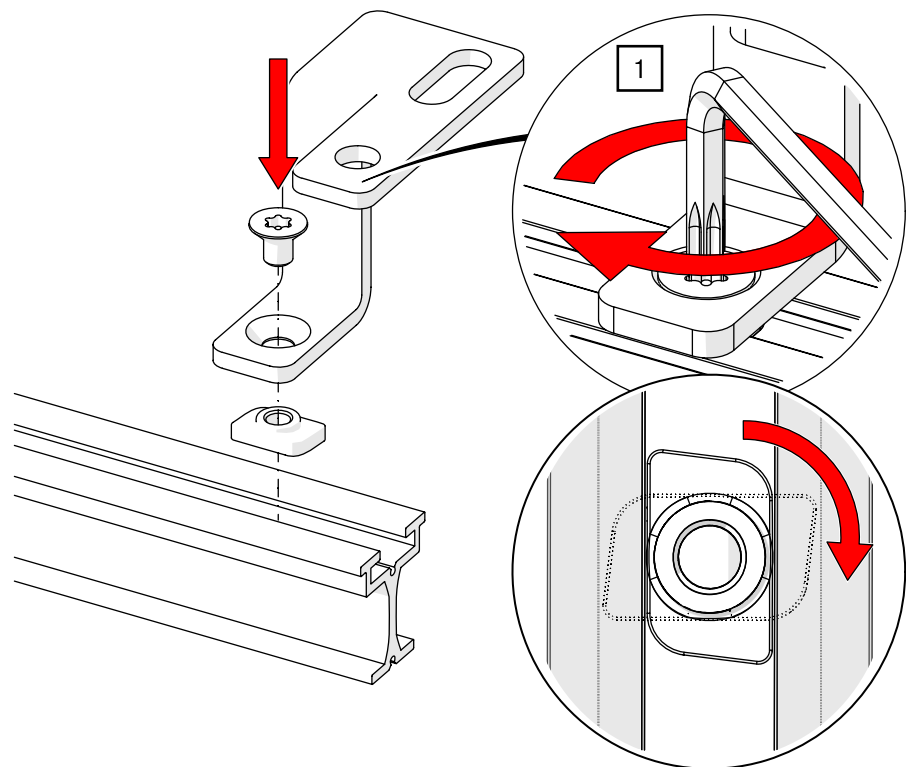

Fig. 63: Assembling the cord operation – Assembly with slot nut

Assembly material for step 2:
 1× pan head screw M12 with
 hexagon socket
 1× nut M12
 1× washer D12

2. Fasten the G-CLAMP to the suspension for cord operation using an 8 mm Allen key and 93 Nm (see Fig. 64).

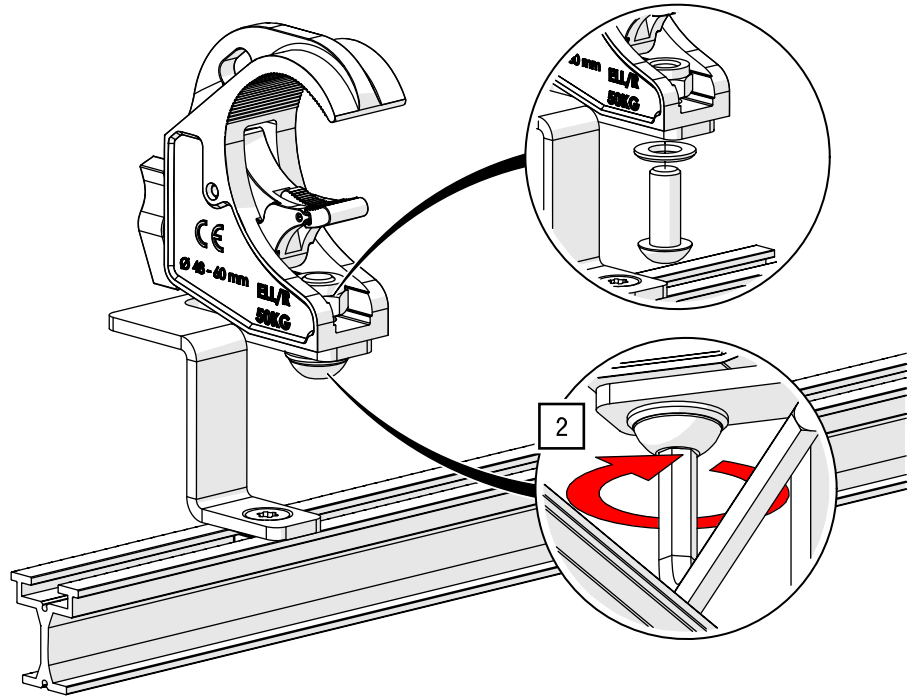

Fig. 64: Assemble cord operation – Assembly with slot nut

3. Open the pipe clamps to the maximum and lift them onto the pipe of the supporting structure (see Fig. 65).

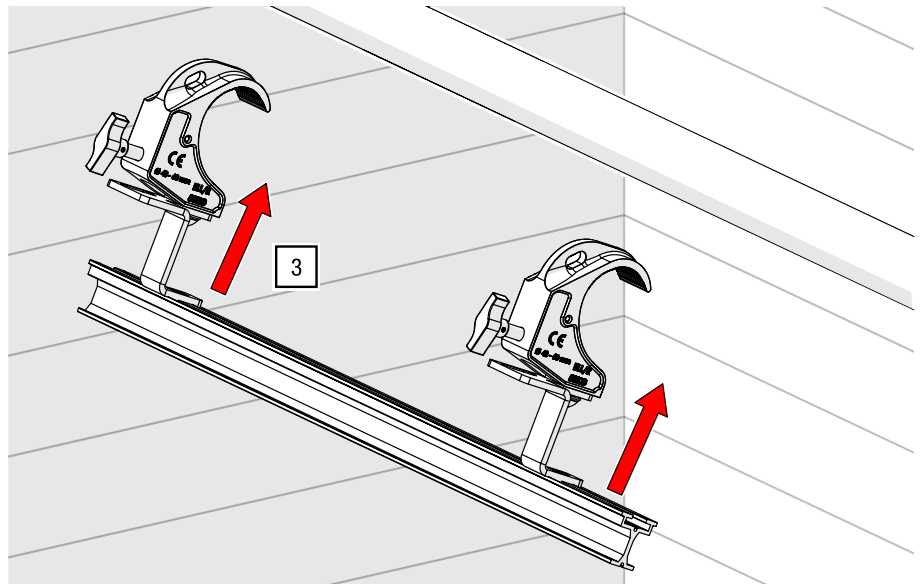

Fig. 65: G-CLAMP – Position on pipe

4. Fasten the G-CLAMP hand-tight to the pipe (see Fig. 66).

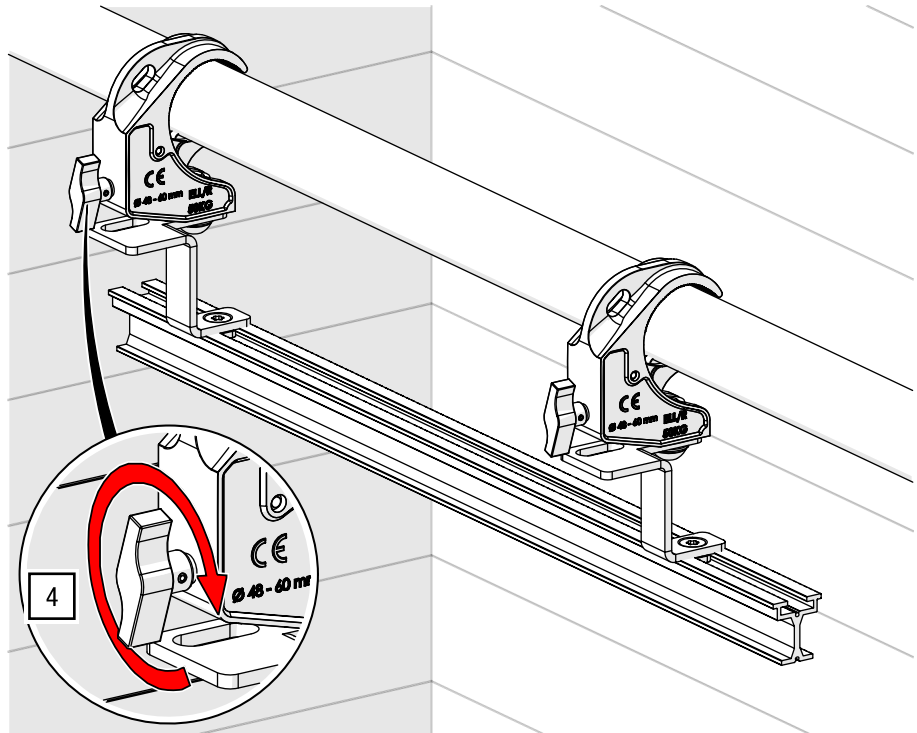

Fig. 66: G-CLAMP – Attach to pipe

5.3.5 Wall mount bracket direct – Walk-along track

Materials / tools required

Quantity	Materials / Tools
Corresponding number of suspensions	Mounting material suitable for the substrate: <ul style="list-style-type: none"> • Concrete wall: e.g. drive-in anchor E M10 × 40, hexagon head screw M10 × 30 (ISO 4017) • Wooden ceiling / plasterboard according to substrate
1	Suitable tools e.g. drill (not included)
Quantity according to order	wall mount bracket – Item no. 31150 088XX
1	13 mm open-end wrench (not included)

Tab. 18: Materials / tools for mounting the rope guide on the wall bracket

Install wall mount bracket for direct mounting on concrete wall

1. Screw the wall mount bracket to the wall using the appropriate mounting material for the surface (assembly according to the manufacturer's instructions; example concrete wall – see Fig. 67).



Make sure that the surface for the assembly of the wall mount brackets is as level as possible. Use aids such as cross and line lasers to determine the mounting points.

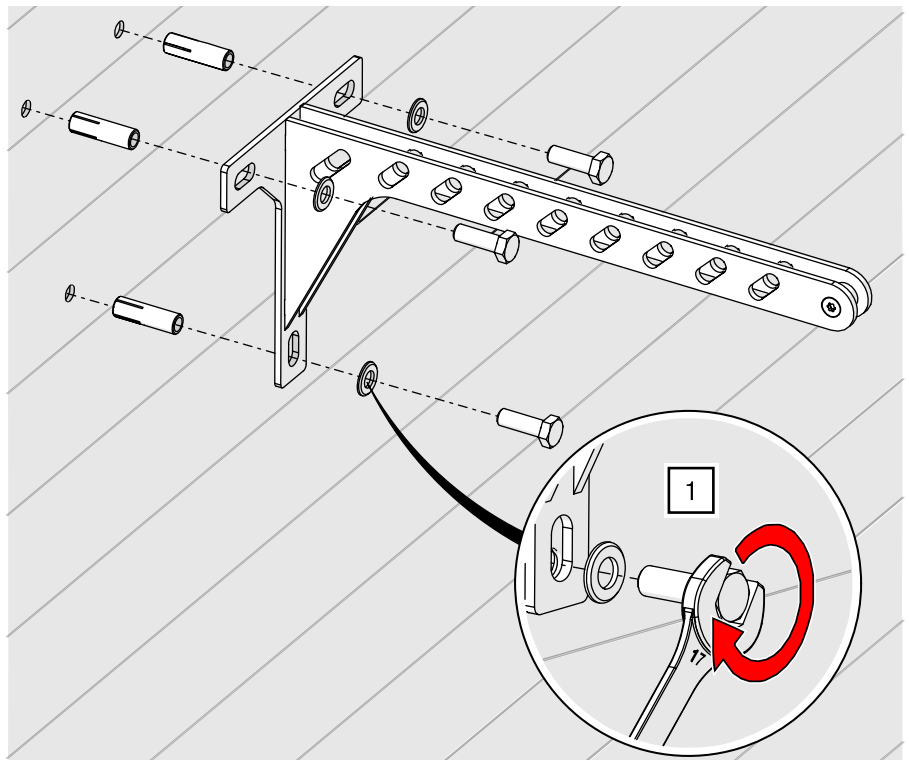

Fig. 67: TRUMPF 95 wall mount bracket – Mounting

Assembly material for step 2:

1× hexagon head screw M8

1× spring washer 8

1× washer D8

1× lid

1× standard slot nut

- Place the U-sheet metal on the wall mount bracket and the slot nut and turn the screw a few turns by hand (see Fig. 68).

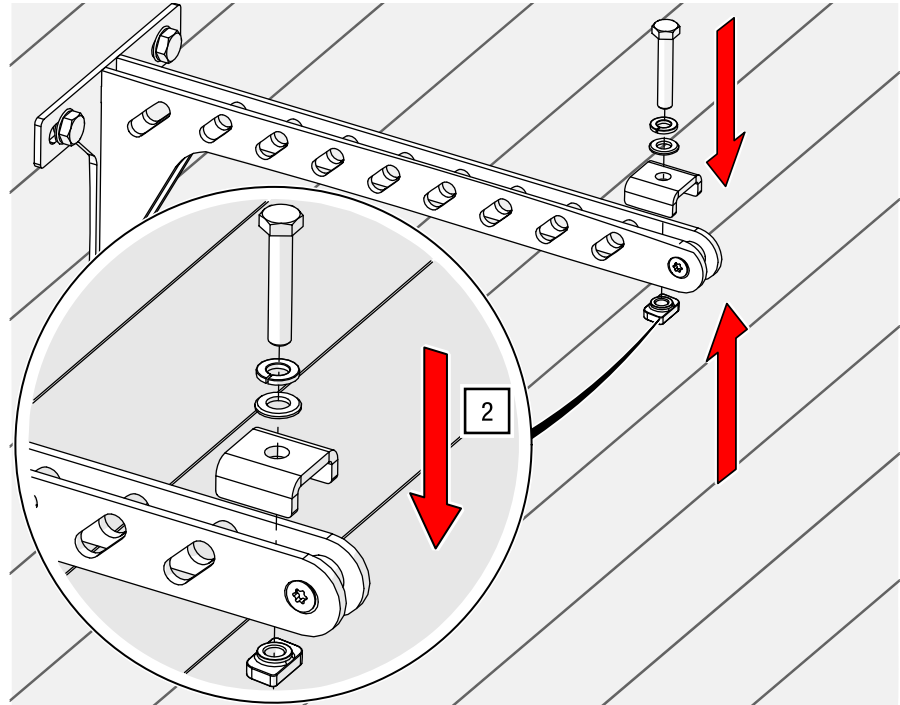

Fig. 68: Wall mount bracket – Pre-assemble screws with slot nut

- Lift the profile to the wall mount bracket and screw both together using a ring spanner or open-end wrench AF 13 and 27 Nm (see Fig. 69).

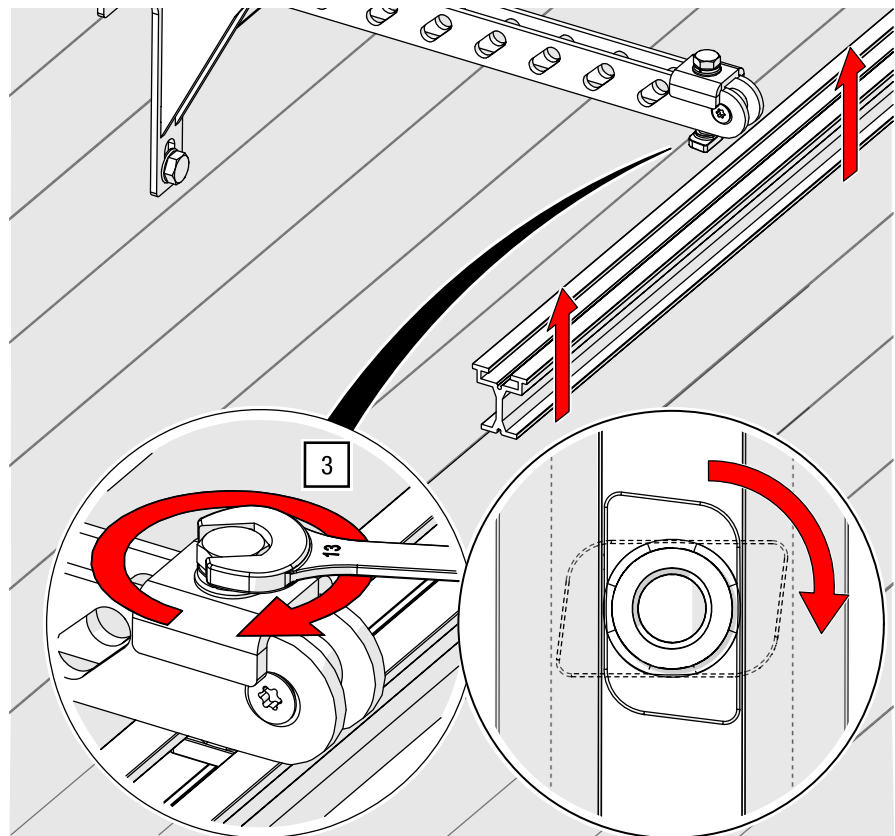

Fig. 69: Wall mount bracket – Mount the track on the wall mount bracket

5.3.6 Wall mount bracket – Cord operation

Materials / tools required

Quantity	Materials / Tools
Corresponding number of suspensions	Mounting material suitable for the substrate: <ul style="list-style-type: none"> • Concrete wall: e.g. drive-in anchor E M10 × 40, hexagon head screw M10 × 30 (ISO 4017) • Wooden ceiling / plasterboard according to substrate
1	Suitable tools e.g. drill (not included)
Quantity according to order	Wall mount bracket – Item no. 31000 088XX
1	Open-end wrench AF 17 (not included)
1	TORX®-key T40 (not included)
1	Open-end wrench AF 16 (not included)

Tab. 19: Materials / tools required for direct ceiling mounting

Install wall mount bracket for direct mounting on concrete wall

1. Screw the wall mount bracket to the wall using the appropriate mounting material for the surface (assembly according to manufacturer's instructions; for example, concrete wall – see step1 in *chapter 5.3.5 Wall mount bracket direct – Walk-along track* [► p. 61]).
2. Fit the ceiling suspension bracket for cord operation to the track using the slot nut and TORX®-key T40 and 27 Nm (see Fig. 70).

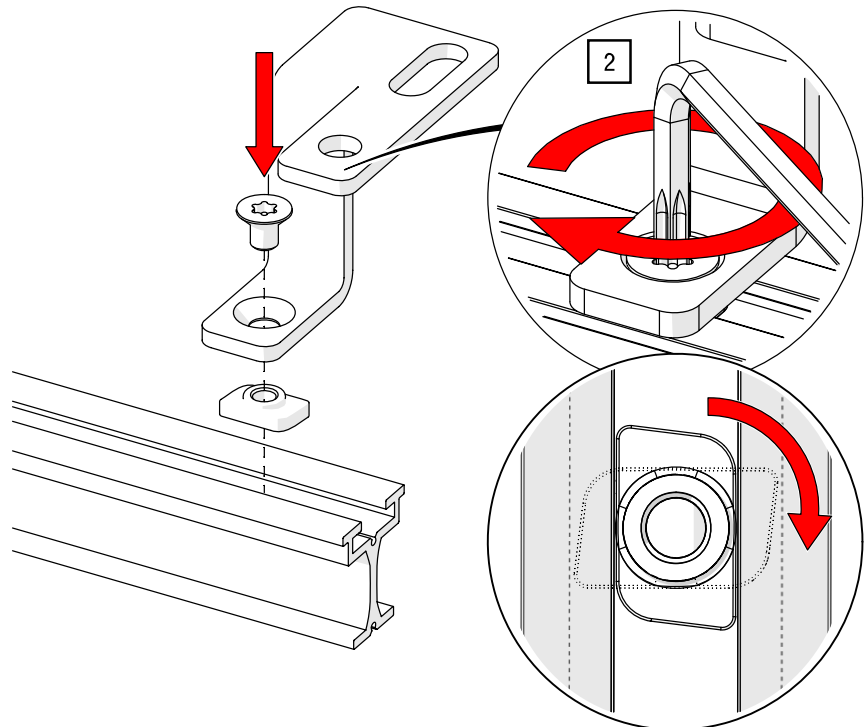

Fig. 70: Assembling the cord operation – Assembly with slot nut

Screw wall mount bracket to suspension

Assembly material for step 3:

1 × hexagon head screw M12

1 × cover

2 × washer D12

1 × nut M12

3. Place the U-sheet metal on the wall mount bracket with the open side facing downwards and screw it to the suspension for cord operation using two open-end wrenches AF 19 and 93 Nm (see Fig. 71).

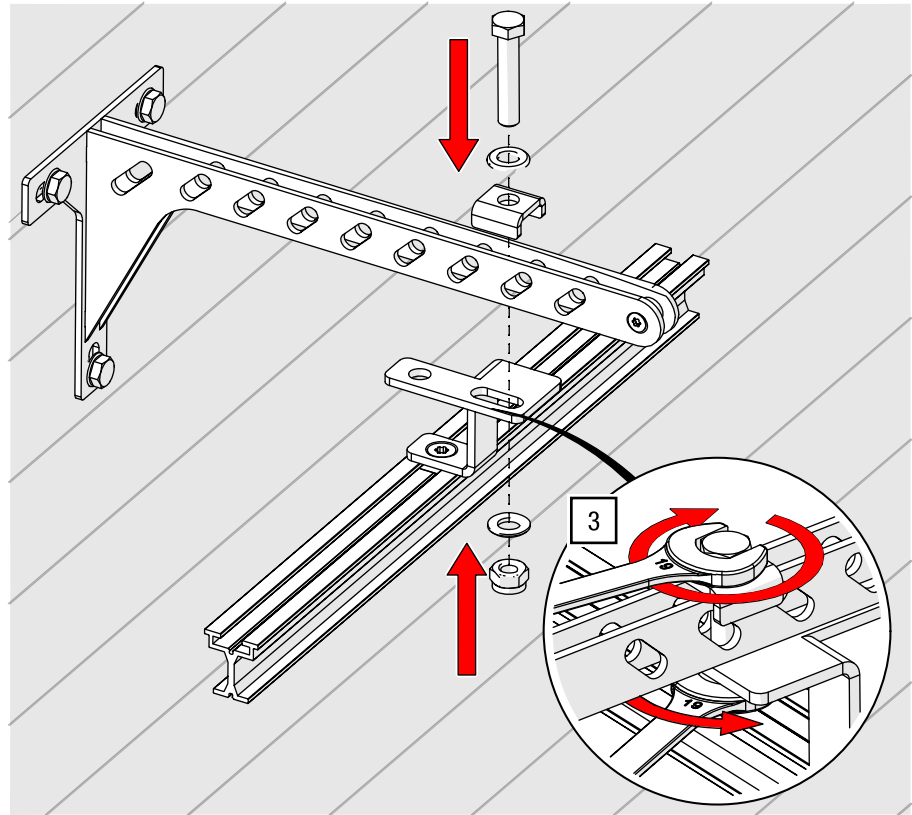

Fig. 71: Screwing the wall mount bracket to the suspension for cord operation

5.4 Installing the cord operation system



Generally, attach the return pulley at the opposite end of the head pulley block a little further inward to compensate for any cord elongation that may occur.

5.4.1 Side cord operation

In the following example, a two-part curtain is installed with the side cord operation. The installation steps or track layouts may differ from the illustrations depending on the product purchased.

Materials / tools required

Quantity	Materials / Tools
1	TR95 return pulley for side cord operation Item no. 31150 00831
1	TR95 / JOKER 95 universal head pulley block for side cord operation – Item no. 31150 00811
According to order	TR95 side cord guide, straight Item no. 31150 04871
Length according to order	Polyester cord Ø 8 mm – Item no. 41040 0118X
1	TORX®-key T40 (not included)
1	TORX®-key T30 (not included)
1	Allen key AF 5 (not included)
1	Open-end wrench AF 16 (not included)
1	Open-end wrench AF 10 (not included)

Tab. 20: Materials / tools required for assembly of the side cord operation

Assembly information:

Final cord positioning and head pulley adjustment

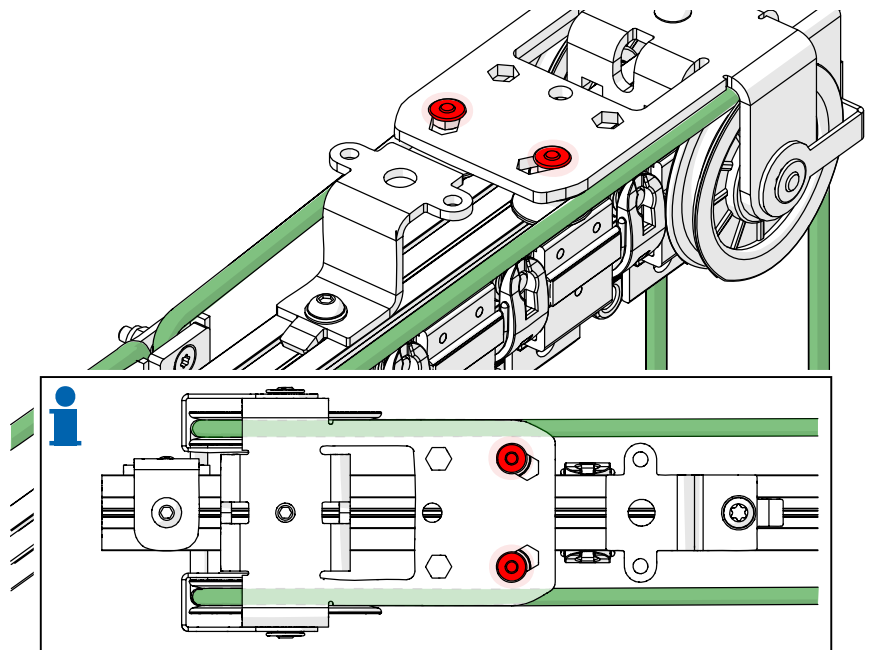

Fig. 72: Side cord operation – Final cord positioning at the head pulley

Assembly information:
Final cord positioning and return pulley adjustment

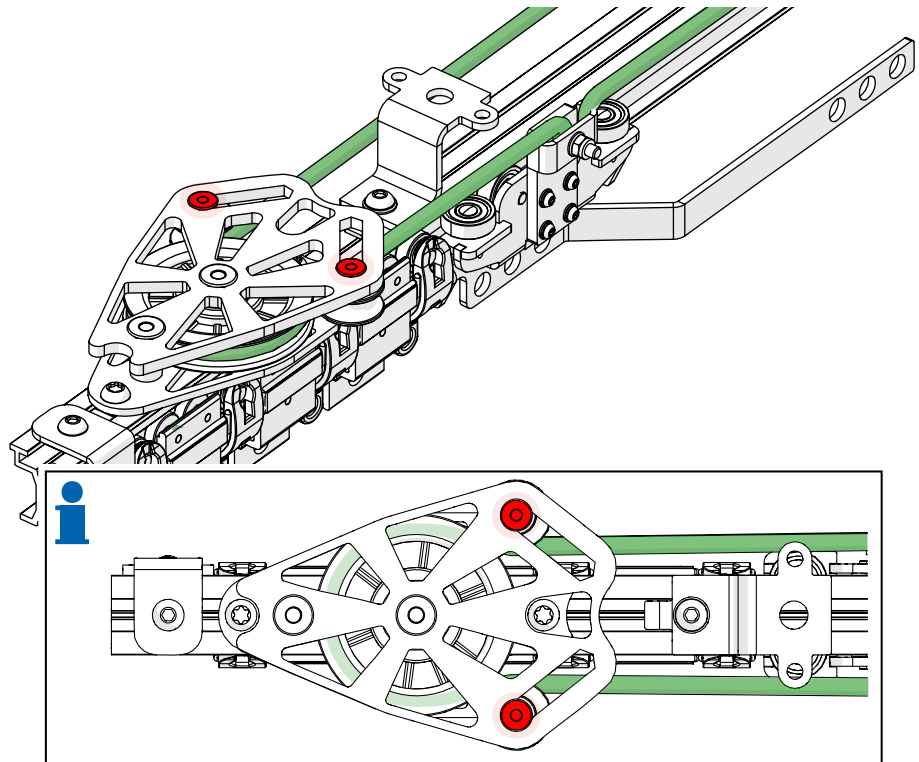

Fig. 73: Side cord operation – Final cord positioning at the return pulley

Assembly cord operation

1. Install the track with suspension and track splice according to *chapter 5.2 Installing the track system* [► p. 42] and *chapter 5.3 Installing suspensions* [► p. 50].
2. Loosen the cord guides on the return pulley, slide them to the position shown and tighten the screws again using a TORX®-key T30 and 11 Nm (see Fig. 74).

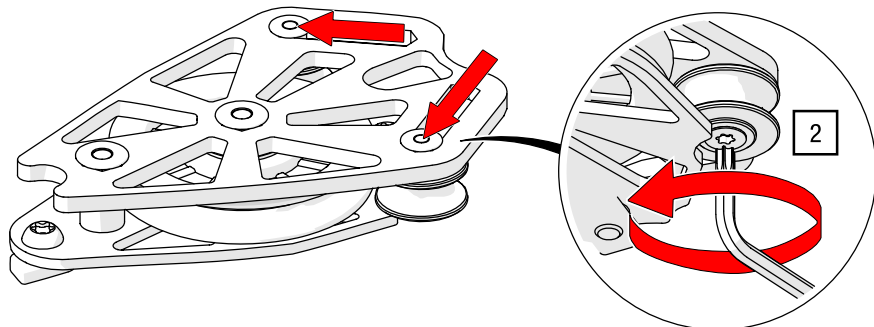

Fig. 74: Side cord operation – Adjusting the return pulley



Depending on the available mounting space, it may make sense to mount the return pulley on the track in advance to make it easier to screw it on.

3. Position the pre-assembled return pulley for side cord operation at one end of the track and tighten the screws with the slot nuts positioned in the track profile using a TORX®-key T40 and 27 Nm (see Fig. 75).

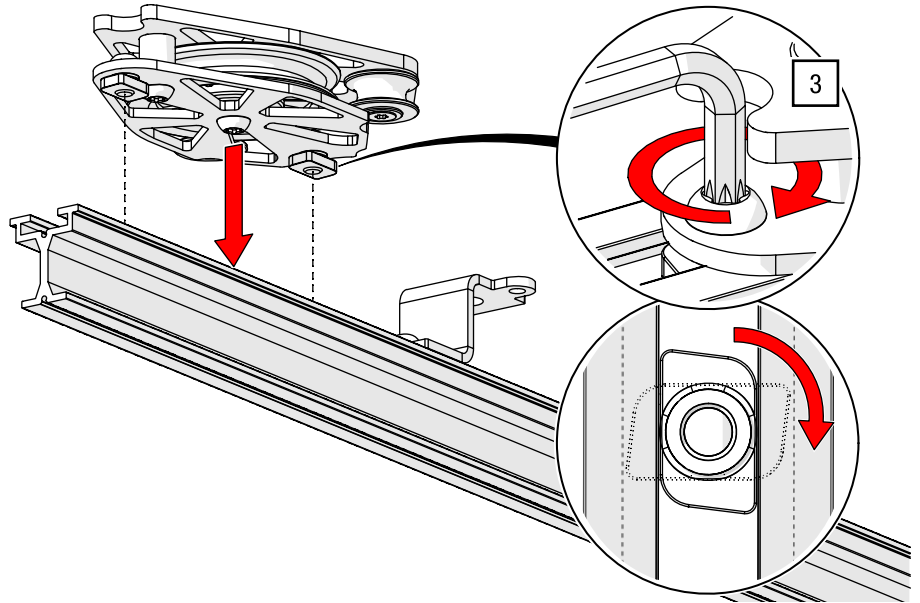

Fig. 75: Side cord operation – Fitting the return pulley

4. Position one of the cord guides supplied close to the suspensions and attach the rest to the track profile (hole on the opposite side of the cord clamp of the master runner) using a TORX®-key T40 and 27 Nm (see Fig. 76).

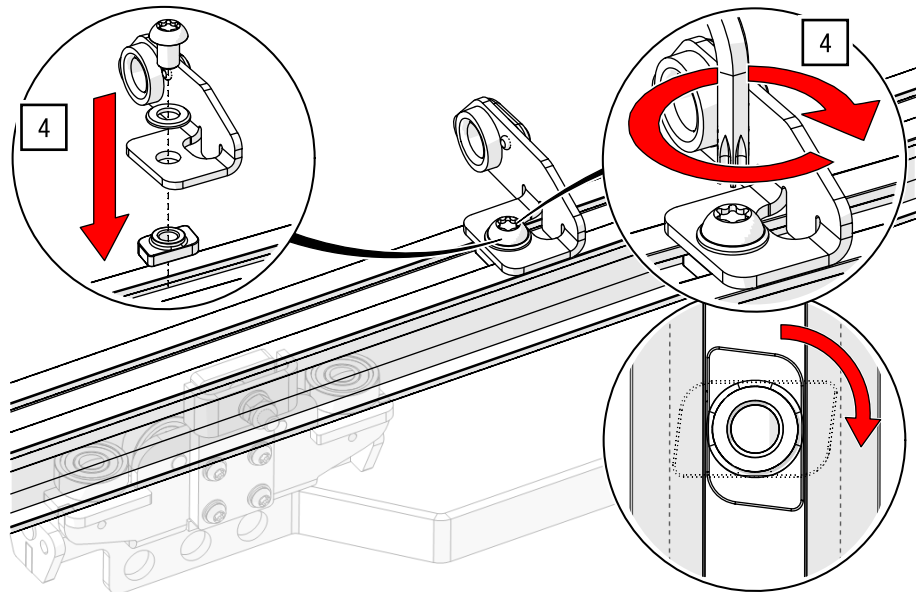

Fig. 76: Side cord operation – Fitting the cord guide

Attach head pulley

5. Use a TORX®-key T30 (see Fig. 77) to position the cord guides on the head pulley in the positions shown.

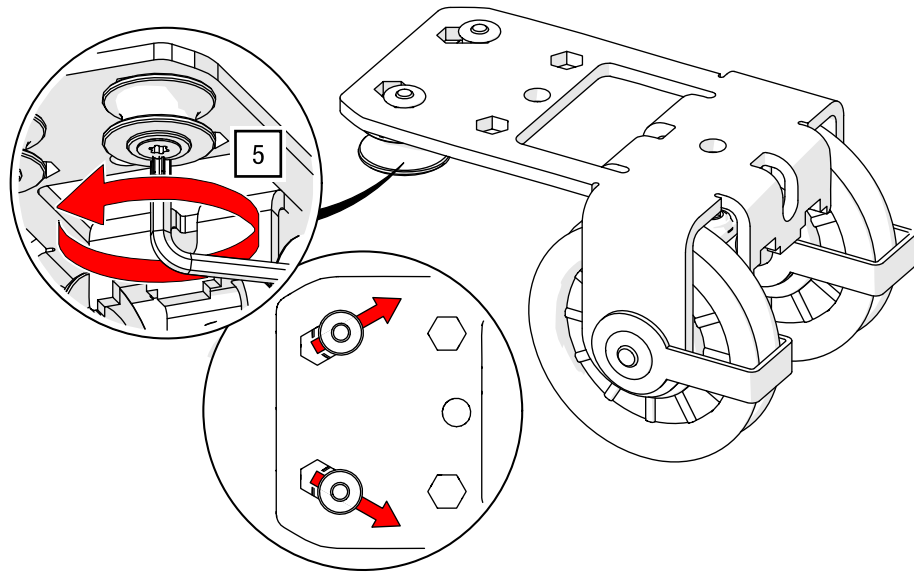

Fig. 77: Side cord operation – Pre-assemble head pulley for side cord operation

6. Position the head pulley at the desired position and screw it tight with an Allen key AF 5 and 27 Nm (see Fig. 78).

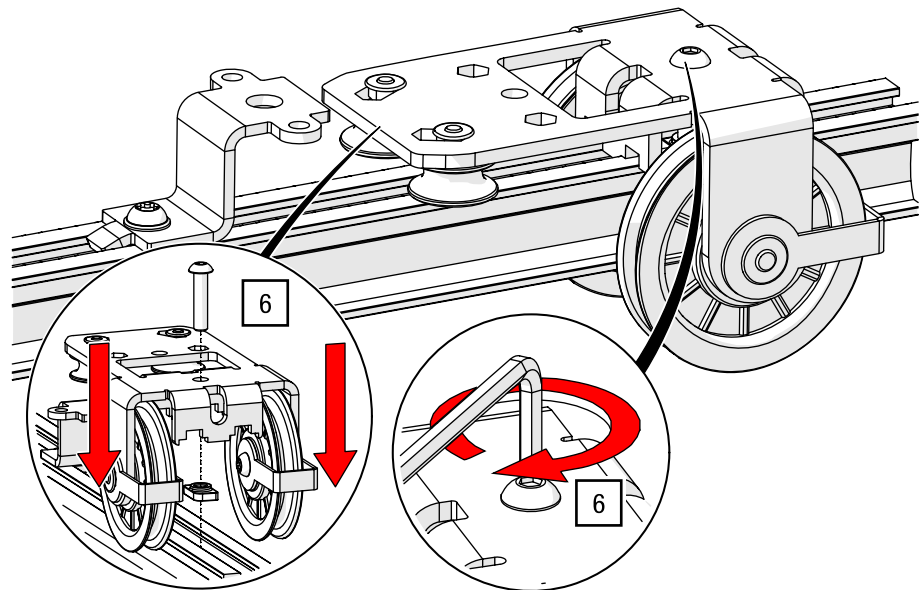

Fig. 78: Side cord operation – Mounting the side cord operation head pulley

Thread on the Runner and master runner and close the track

7. Close the track on one side with an end stop in accordance with *chapter 5.2.4 TRUMPF 95 end stop* [► p. 49].
8. Put the runner and master runner onto the track.
9. Close the second end of the track as described in *chapter 5.2.4 TRUMPF 95 end stop* [► p. 49].

Insert first cord end

10. In the case of a two-part curtain, push the runners and the master runner together as far as possible in the stowage area on each side (see Fig. 79).

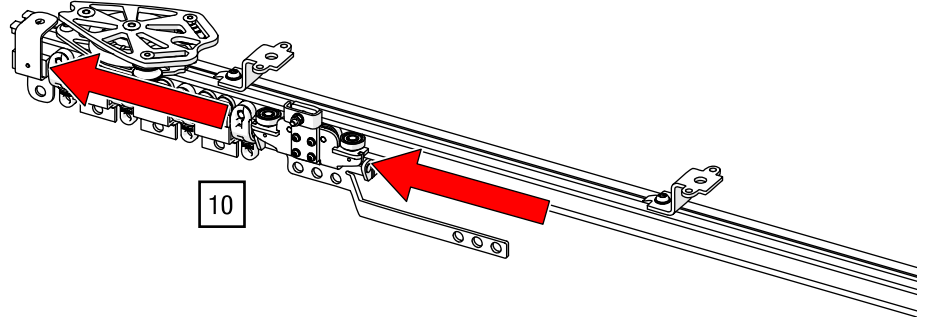

Fig. 79: Side cord operation – Push the trolleys together

11. Pass the cord upwards through the head pulley (see Fig. 80).

12. Guide the cord past the first master runner through the cord operation (see Fig. 80).

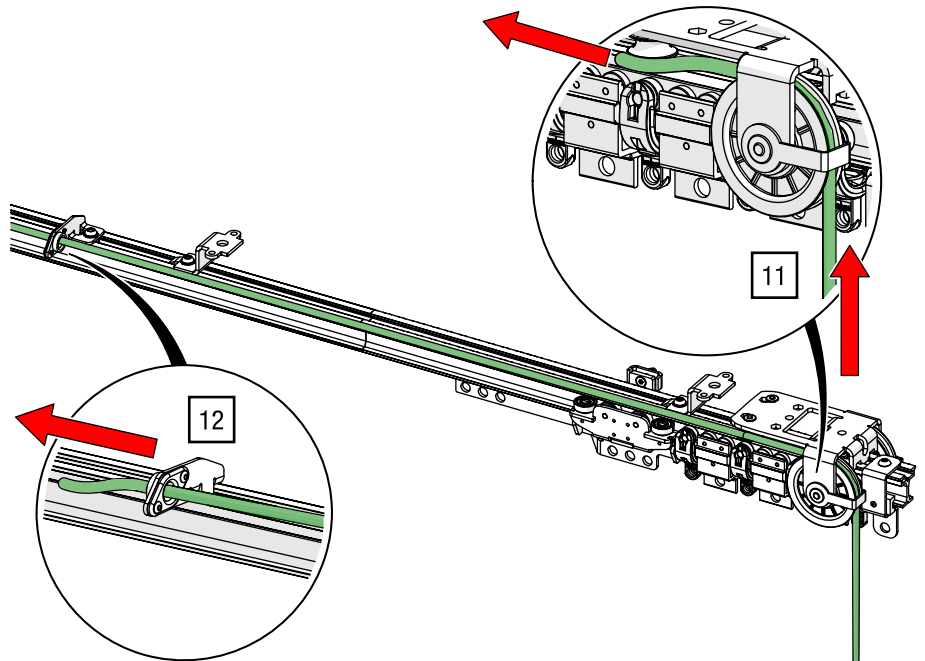

Fig. 80: Side cord operation – Guide the cord through the head pulley and cord guide

13. Guide the end of the cord through the return pulley (see Fig. 81).

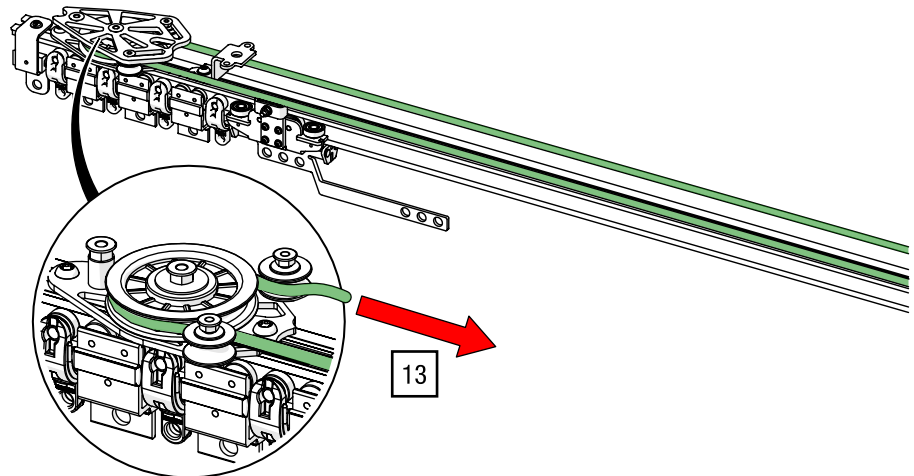

Fig. 81: Side cord operation – Guide the end of the cord through the return pulley

14. Guide the end of the cord through the straight cord guide and into the cord clamp of the master runner on the side of the head pulley (see Fig. 82).

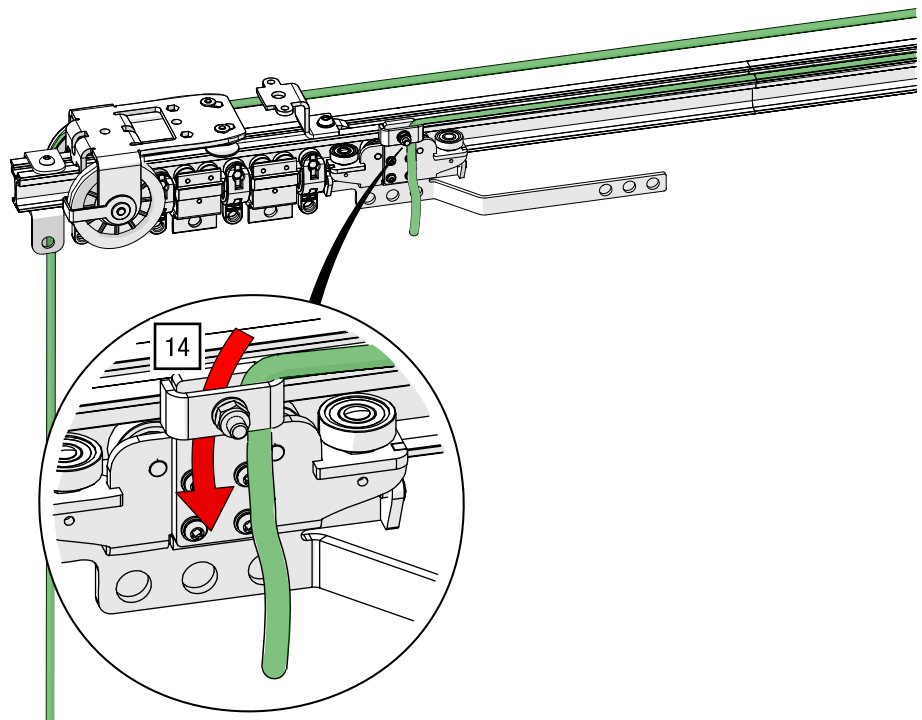

Fig. 82: Side cord operation – Guide the end of the cord through the return pulley into the master runner (view revolved)

Fastening of manual drive

15. Install the pulley / manual drive intended for your track system below the head pulley (see *Installing manual rope drives* [► p. 88]).

Insert second cord end

16. Guide the second cord end up through the head pulley and through the cord operation into the second master runner (see step 11 – Fig. 80 [► p. 69]).

17. Clamp both cord ends in the second master runner with an open-end wrench AF 10 at 11 Nm and tie them together with two tie wraps (see Fig. 83).



After the clamp there should be still enough length for the cord-end to readjust the cord operation system, if necessary.

18. Cut off the ends of the cord with a wire cutter and burn the cut surface, so that the rope does not unravel (see Fig. 83).

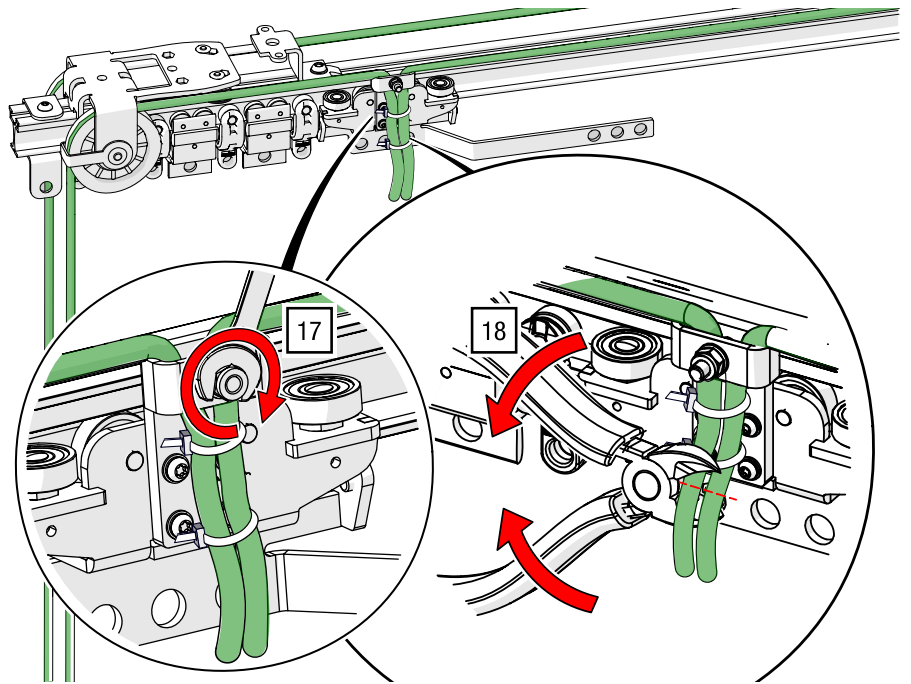

Fig. 83: Side cord operation – Fasten, trim, and burn the ends of the cord

19. Clamp the cord in the first master runner at the return pulley and tighten the nut with a 10 mm open-end wrench (see Fig. 84).

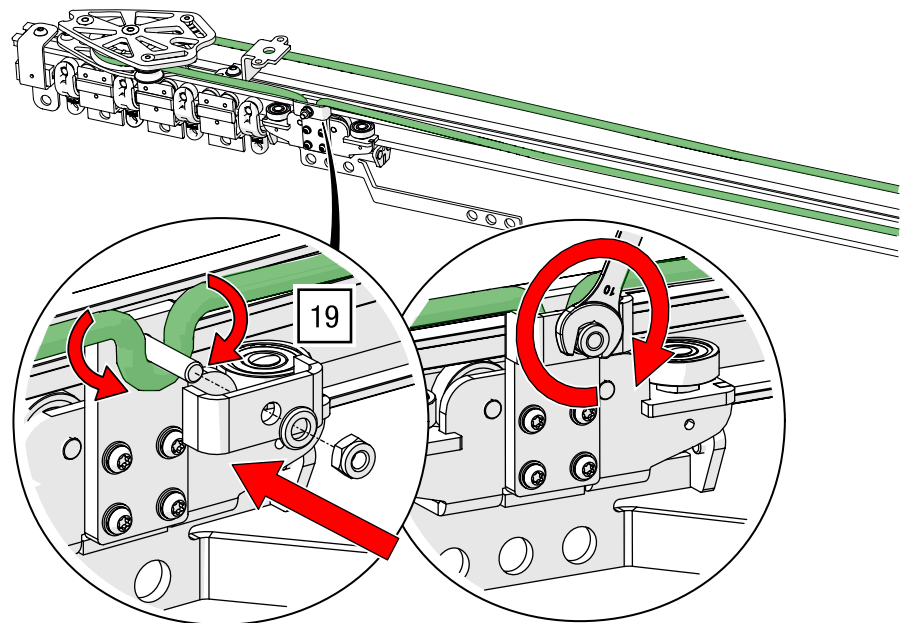

Fig. 84: Side cord operation – Clamp the cord to the second master runner

5.4.2 Top cord operation

The installation steps or track layouts may differ from the illustrations depending on the product purchased.

Materials / tools required

Quantity	Materials / Tools
1	TR95 return pulley – Item no. 31150 00831
1	TR95/JOKER 95 universal head pulley block Item no. 31150 00811
Number of corresponding orders	TRUMPF 95 top cord guide for curved track sections – Item no. 31150 03875
Number of corresponding orders	TR95 top cord guide; straight Item no. 31150 03871
Length according to order	Polyester cord Ø 8 mm – Item no. 41040 0118X
1	TORX®-key T40 (not included)
1	TORX®-key T30 (not included)
1	Allen key AF 5 (not included)
1	Open-end wrench AF 16 (not included)
1	Open-end wrench AF 10 (not included)

Tab. 21: Materials / tools required for assembly of the top cord operation

Assembly information:
Final cord positioning and head pulley adjustment

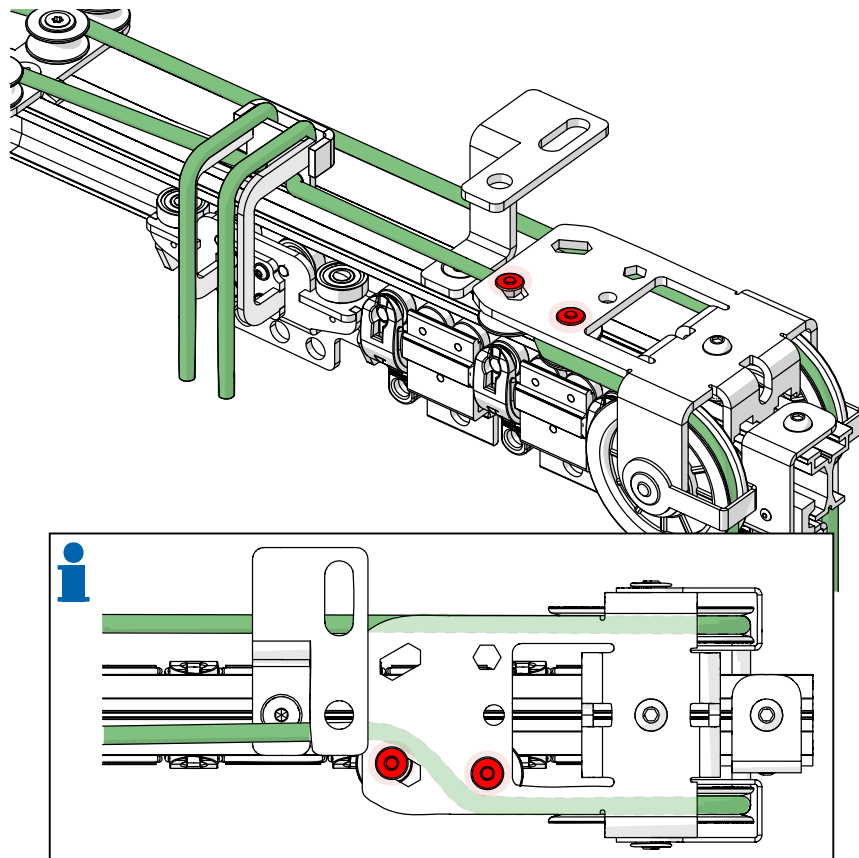

Fig. 85: Top cord operation – Final cord positioning at the head pulley

Assembly information:
Final cord positioning and return pulley adjustment

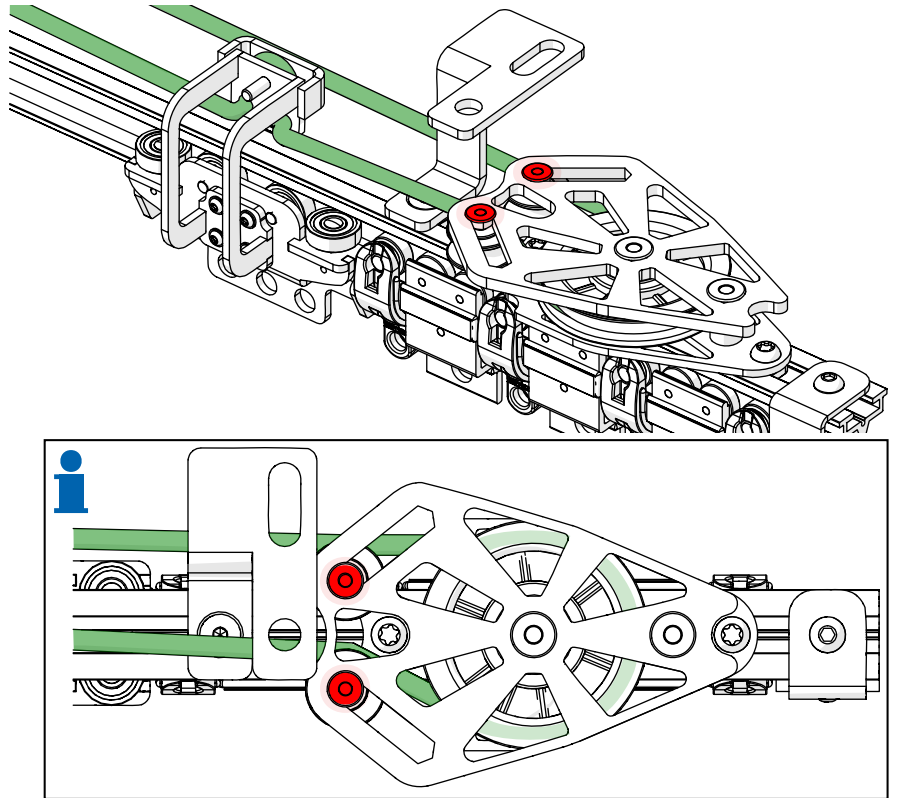

Fig. 86: Top cord operation – Final cord positioning at the return pulley

Assembly cord operation

1. Install the track with suspensions and track splices and double suspension brackets as described in *chapter 5.2 Installing the track system* [► p 42] and *chapter 5.3 Installing suspensions* [► p. 50].
2. Loosen the cord guides on the return pulley, slide them to the outer position, and tighten the screws again using a TORX®-key T30 and 11 Nm (see Fig. 87).

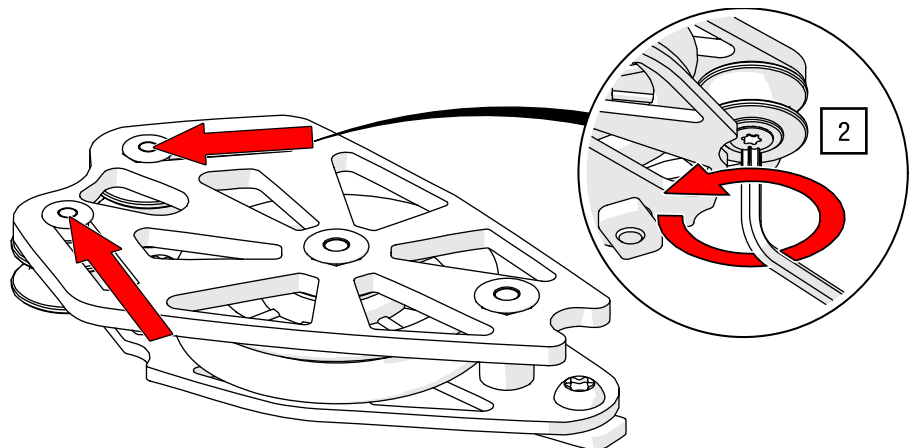

Fig. 87: Top cord operation – Adjusting the return pulley



Depending on the available assembly space, it may make sense to adjust the return pulley before assembling the track.

3. Position the pre-assembled return pulley (top cord operation) at one end of the track and tighten the screws with the slot nuts positioned in the track profile using a TORX®-key T40 and 27 Nm (see Fig. 88).

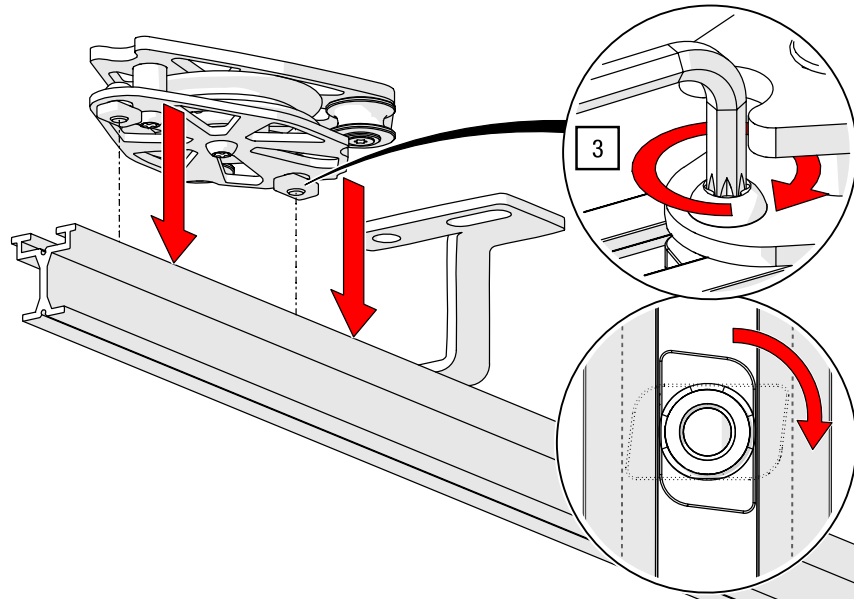

Fig. 88: Top cord operation – Fitting the return pulley

4. Position one of the supplied cord guides in each of the curves close to the suspensions and attach the rest to the track bend (double pulley on the opposite side of the cord clamp) using a TORX®-key T40 and 27 Nm (see Fig. 89).

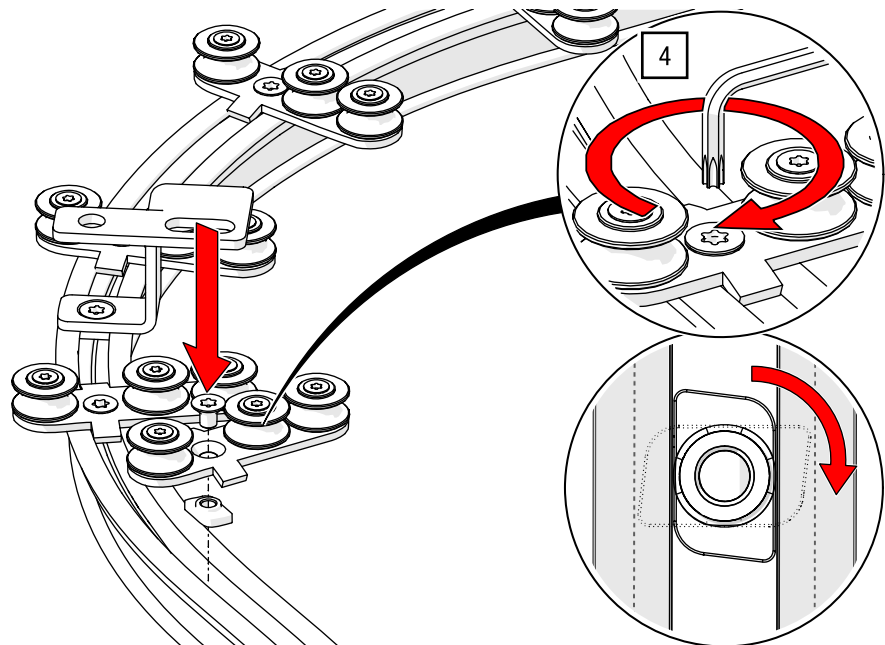

Fig. 89: Top cord operation – Install cord guide for curve

Deviation for track change depending on rail system:

Double-track system:

Position the rope guide on the additional track run (see Fig. 90).

Single-track system:

Position the rope guide within the track run (see Fig. 91).

5. Install additional rope guides to set up a track change and route the rope to the opposite side (example illustrations for positioning the rope guides).

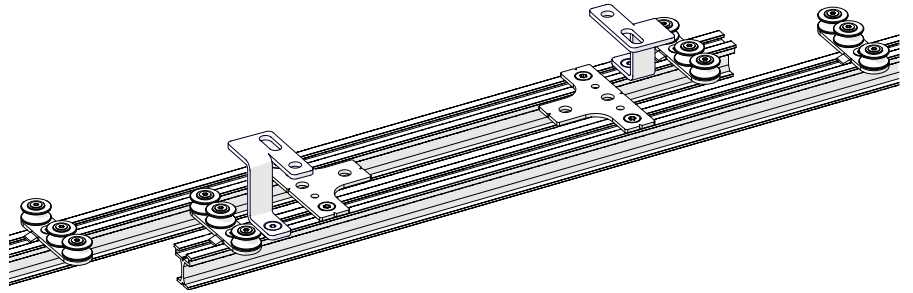

Fig. 90: Top cord operation – Track change on double track system

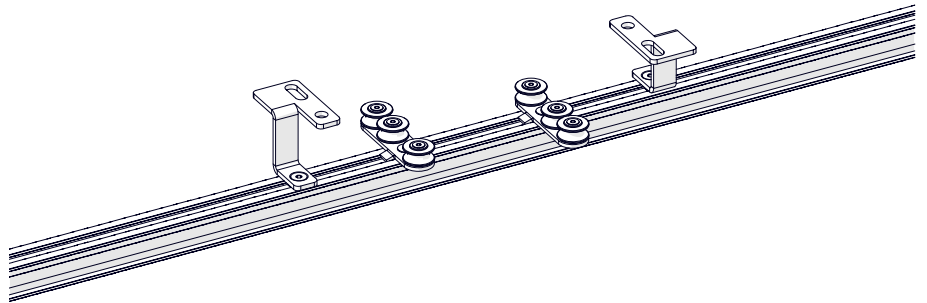

Fig. 91: Top cord operation – Track change on single-track system



A small deflection angle reduces lateral forces and wear in the rope run. A practical guideline value is approximately 30° , even though this angle cannot be achieved in all installation situations due to design-related constraints of individual products, such as deflection and return pulleys as well as track layouts.

Therefore, position the rope guides so that the deflection angle is kept as small as possible within the technical constraints.

6. Position one of the straight cord guides near each of the suspensions, distribute the rest along the remaining straight track section (protruding side on the opposite side of the cord clamp) and screw it on with a TORX® T40 key and 27 Nm (see Fig. 92).

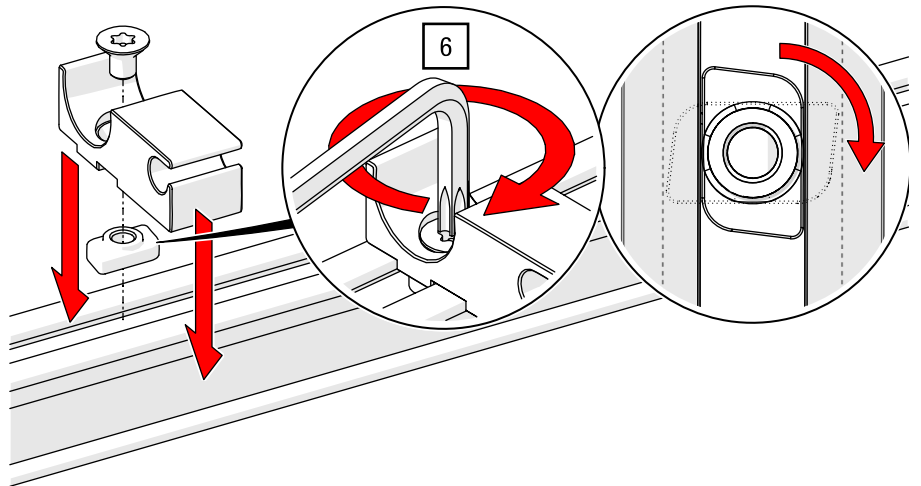

Fig. 92: Top cord operation – Mount the cord operation straight

Attach head pulley



7. Position the cord guides on the head pulley with a TORX®-key T30 in position for the top cord operation (see Fig. 93).

The position of the cord guides on the head pulley is based on the cord clamping of the adjacent master runner. The cord guide on the slotted hole is screwed further to the end to guide the cord towards the centre of the track (see infographic at the beginning of the chapter — Fig. 85 [► p. 72]).

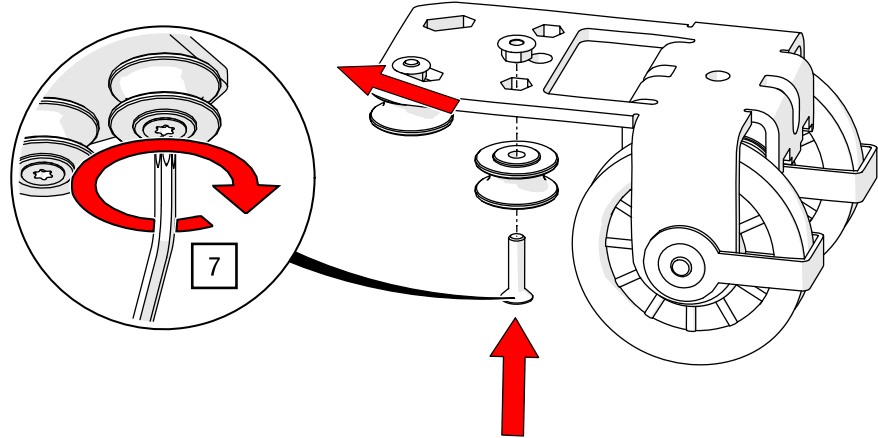

Fig. 93: Top cord operation – Adjusting the head pulley

8. Position the head pulley in the desired position and screw it tight using an Allen key AF 5 and 27 Nm (see Fig. 94).

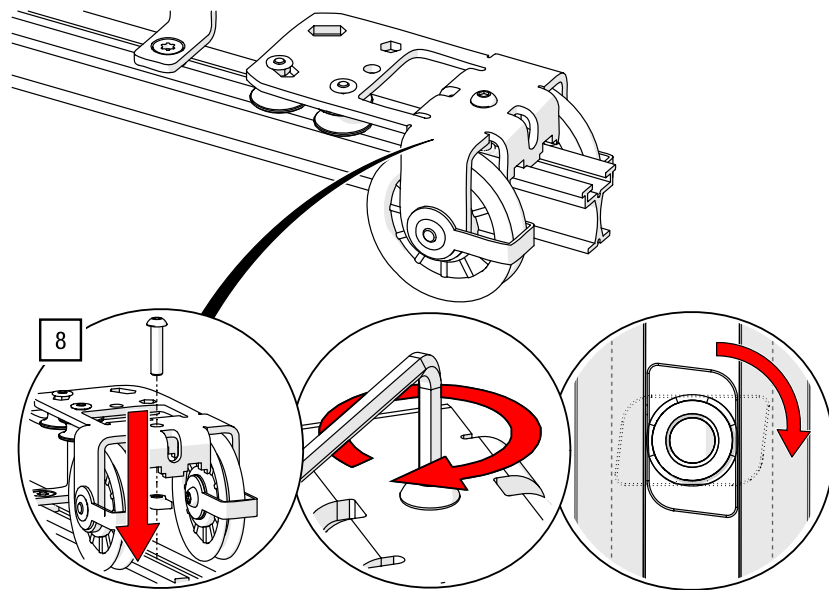

Fig. 94: Top cord operation – Mounting the head pulley

Thread on the runners and master runner and close the track

9. Close the track on one side with an end stop in accordance with *chapter 5.2.4 TRUMPF 95 end stop* [► p. 49].
10. Slide the runner and master runner onto the track.
11. Close the second end of the track as described in *chapter 5.2.4 TRUMPF 95 end stop* [► p. 49].

Insert first cord end

12. In the case of a two-part curtain, push the runner and master runner together as far as possible in the stowage area on each side (see Fig. 95).

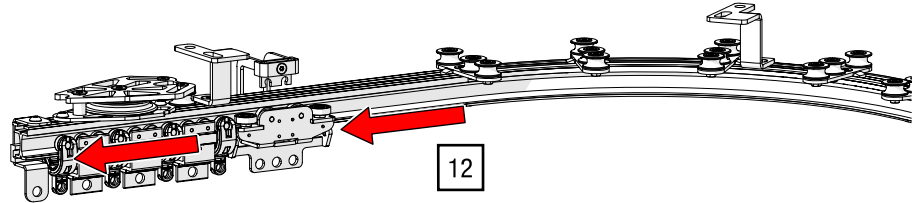

Fig. 95: Top cord operation – Push the trolleys together

13. Pass the cord upwards through the head pulley (see Fig. 96).



Inserting of the cord into the cord operation system begins on the opposite side of the cord clamp (cord ends). The cord ends are always clamped to the master runner that is at the track end of the head pulley (see infographic at the beginning of the chapter -Fig. 85 [► p. 72]).

14. Guide the rope past the first carrier through the rope guides (see Fig. 96).

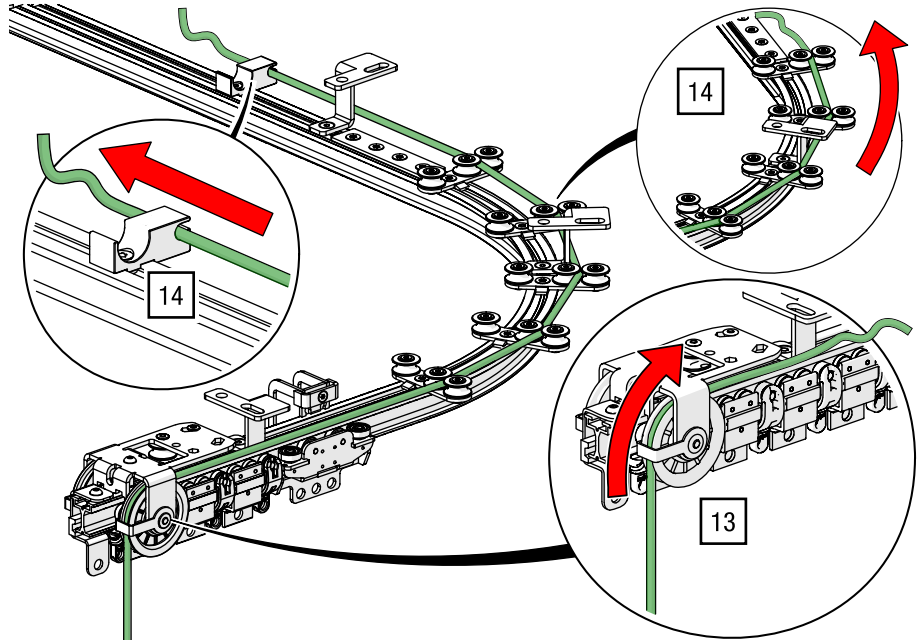

Fig. 96: Top cord operation – Guide the cord through the head pulley and cord operation

Note:

For single-track systems, the rope routing differs; see Fig. 104

[► S. 81]

15. Guide the end of the cord through the two return pulleys onto the second track (see Fig. 97).

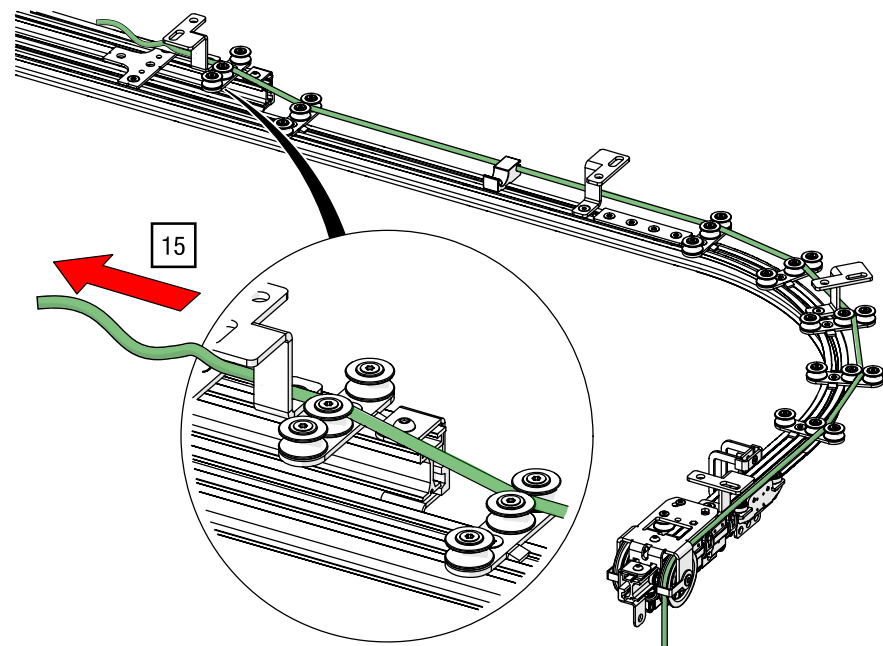

Fig. 97: Top cord operation – Guiding the cord to the second track run

16. Guide the end of the cord through the following cord operations (see Fig. 98).

17. Guide the end of the cord on the inside of the guide pulleys through the return pulley (see Fig. 98).

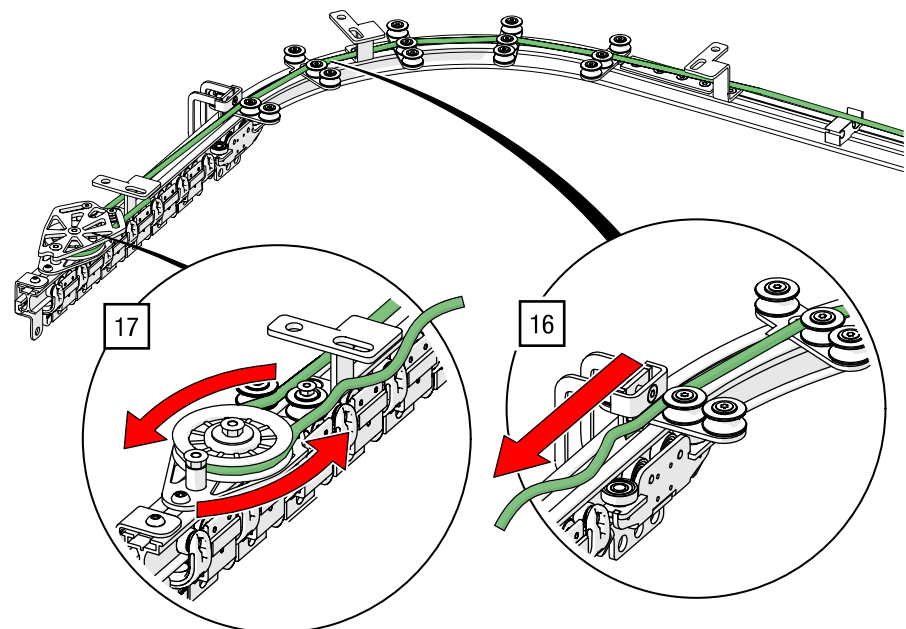

Fig. 98: Top cord operation – Guide the end of the cord through the return pulley into the master runner (return pulley exemplary shown without cover plate)

18. Only for double track systems: guide the cord end through the cord guides back onto the first track section (see Fig. 99).

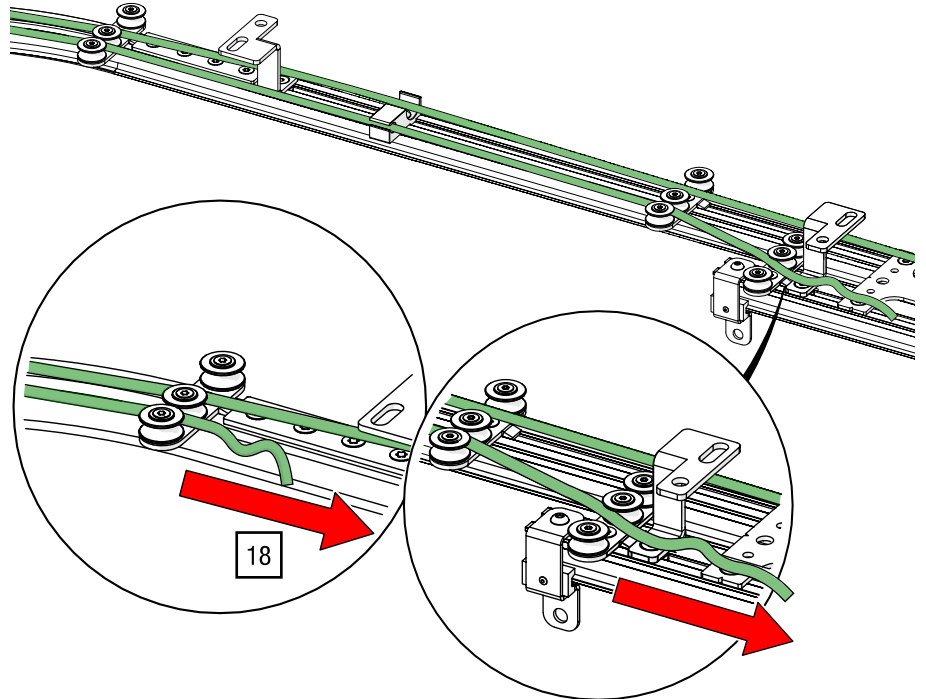

Fig. 99: Top cord operation – Guide the end of the cord back onto the first track section using return pulleys

19. Guide the end of the cord into the clamping unit on the master runner on one side and secure it to the sheet metal at several positions with four tie wraps (see Fig. 100).

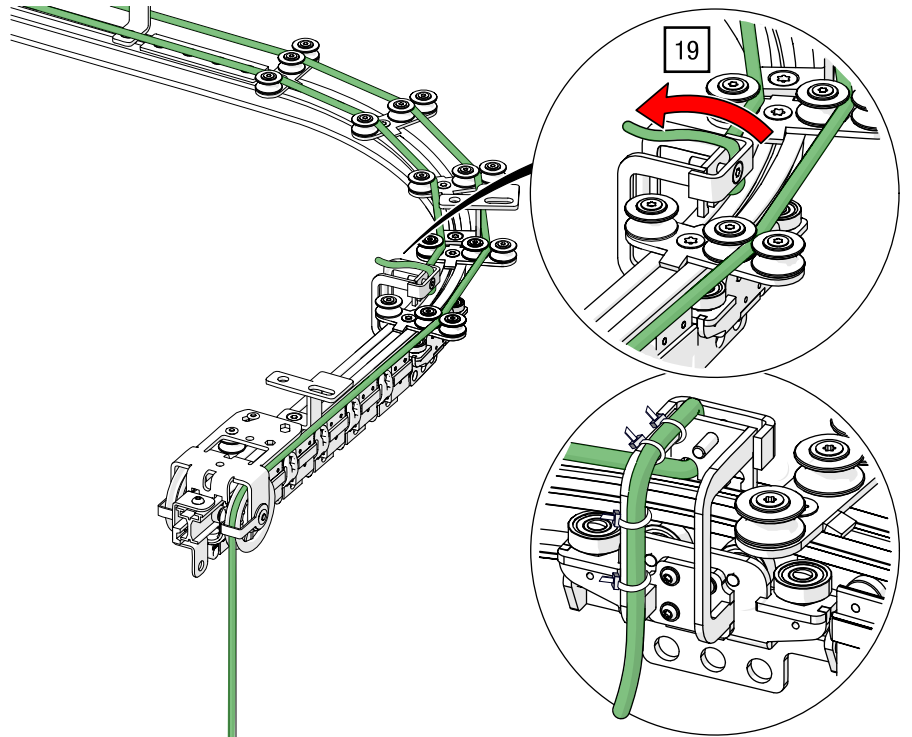

Fig. 100 Top cord operation – Insert cord end into master runner on one side

Insert second cord end

20. Attach a drive designated for your track system below the head pulley in accordance with *chapter 5.5 Installing manual rope drives* [► p. 88].
21. Pass the second end of the cord upwards through the head pulley to the first master runner and tie it to the master runner at several positions with tie wraps (see Fig. 101).

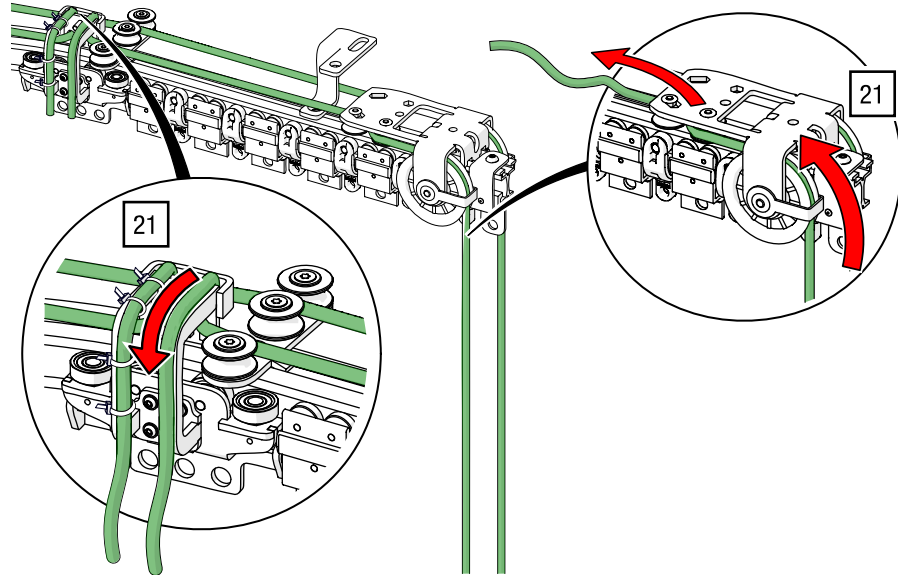

Fig. 101: Top cord operation – Guide cord ends into master runner via head pulley

22. Clamp both cord ends in the second master runner using a TORX®-key T30 and 11 Nm and (see Fig. 102).



After the clamp there should be still enough length for the cord-end to readjust the cord operation system, if necessary.

23. Cut off the ends and burn them, so that the rope does not unravel (see Fig. 102).

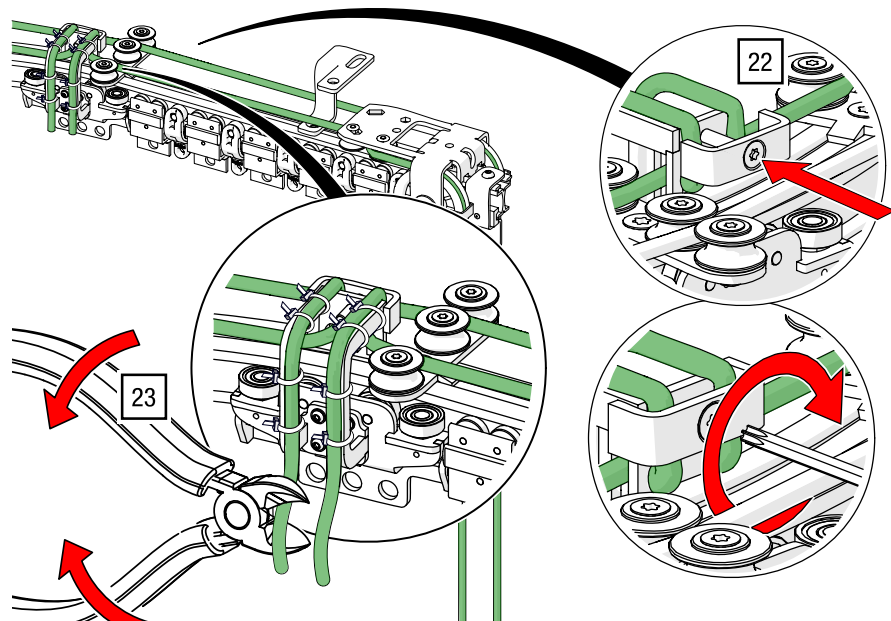

Fig. 102: Top cord operation – Fasten, cut, and burn the ends of the cord

24. Clamp the cord in the second master runner by tightening the screw with a TORX®-key T30 (see Fig. 103).

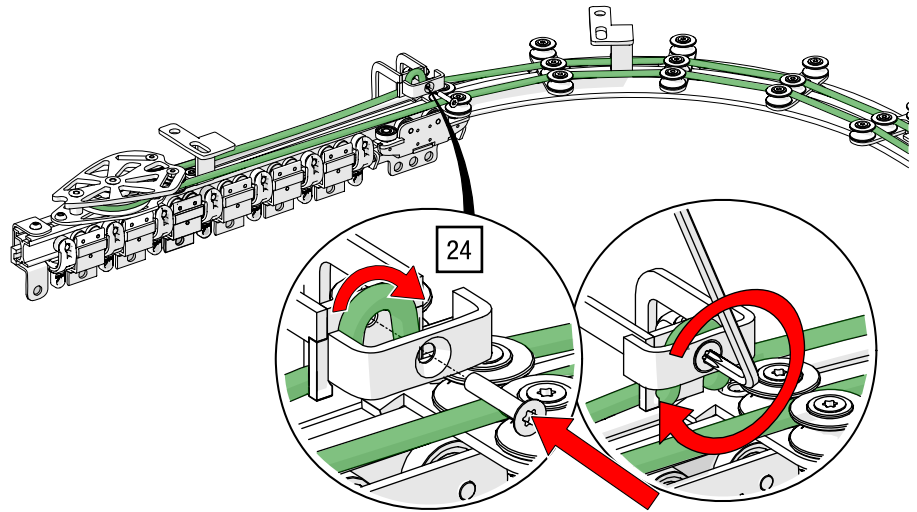

Fig. 103: Top cord operation – Clamp the cord to the second master runner

Deviation: Final rope routing during track change in a single-track rail system

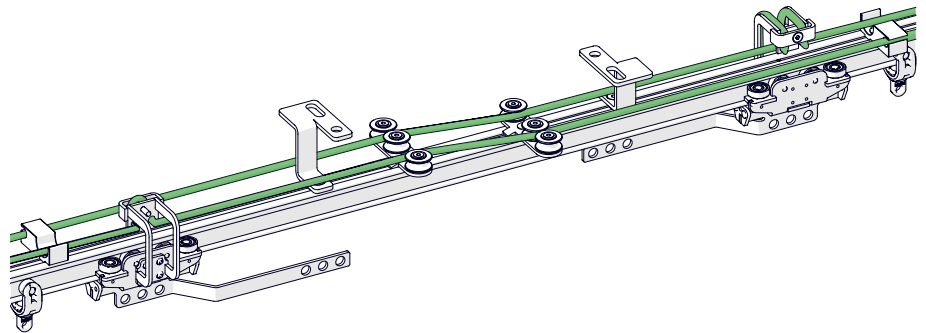

Fig. 104: Top cord operation – Track change in a single-track rail layout

5.4.3 Double top cord operation

The following shows the assembly of a single-track layout with two curtain sections running on the same track. The installation steps or track layouts may differ from the illustrations depending on the product purchased.

Materials / tools required

Quantity	Materials / Tools
1	TRUMPF 95 head pulley for double top cord operation Item no. 31150 05811
1	TRUMPF 95 return pulley for double top cord operation Item no. 31150 05831
Quantity according to order	TRUMPF 95 double top cord guide, straight Item no. 31150 05871
Quantity according to order	TRUMPF 95 double top cord guide Item no. 31150 05875
Length according to order	Polyester cord 8 mm – Item no. 41040 0118X
1	TORX®-key T40 (not included)
1	TORX®-key T30 (not included)

Tab. 22: Materials / tools required for assembly of the double top cord operation

Assembly cord operation

1. Install the track with suspensions and track splices and double suspension brackets as described in *chapter 5.2 Installing the track system* [► p. 42] and *chapter 5.3 Installing suspensions* [► p. 50].
2. Mount the return pulley at one end of the track and tighten the screws with the slot nut positioned in the track profile using a TORX®-key T40 and 27 Nm (see Fig. 105).

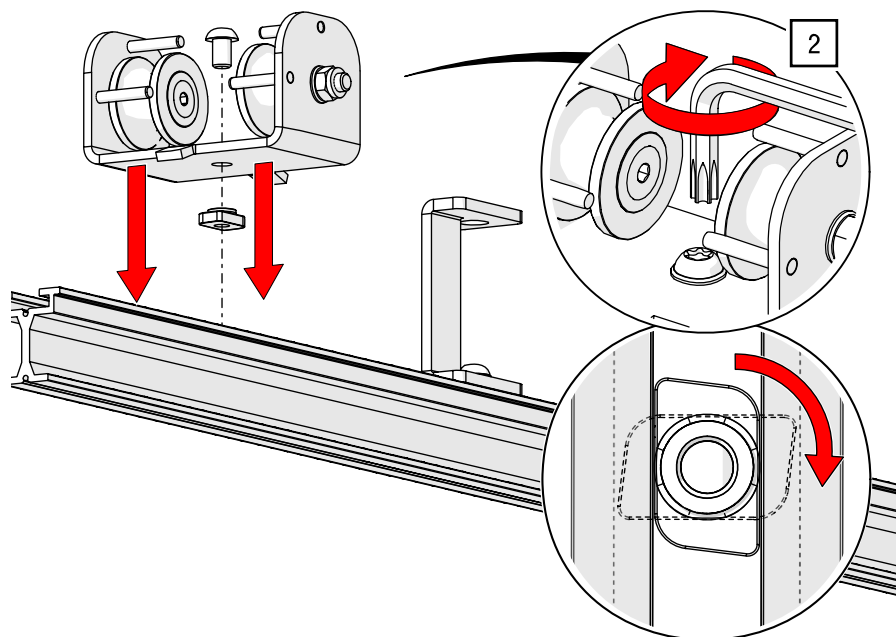

Fig. 105: Double top cord operation – Mounting the return pulley

3. Position one of the straight cord guides close to the suspensions, distribute the rest on the remaining straight track section and tighten the screw with a TORX®-key T40 and 27 Nm (see Fig. 106).

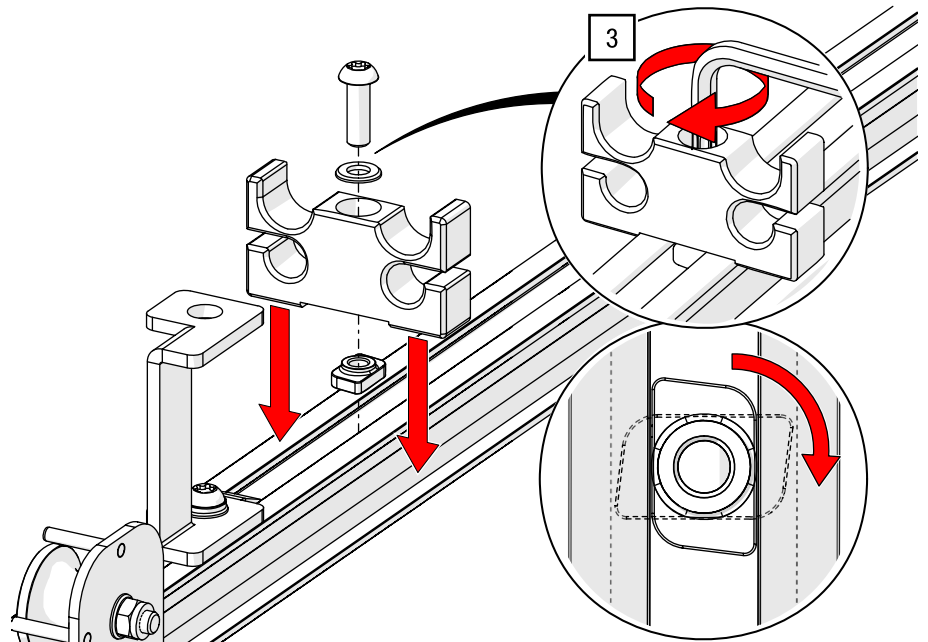

Fig. 106: Double top cord operation – Mount the cord operation straight

4. Position one of the supplied cord guides for curved sections in each of the curves close to the suspension, distribute the rest at the track curve (positioning of the double pulley in opposite to the cord clamp on the master runner) and tighten the screw with a TORX®-key T40 and 27 Nm (see Fig. 107).



Make sure to attach the cord guides in the track curve as close as possible to the suspensions to prevent the operational cord from dragging.

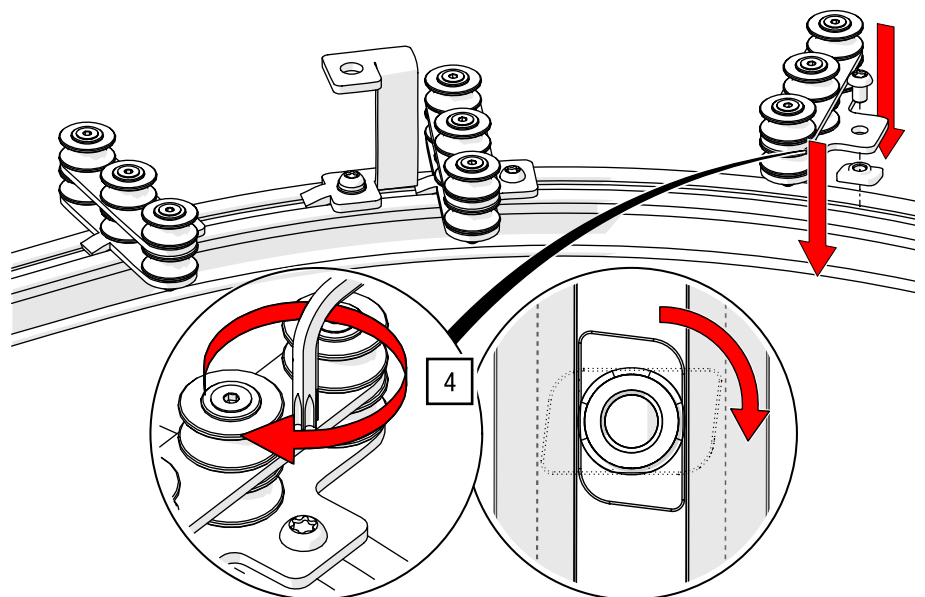

Fig. 107: Double top cord operation – Installing the cord guide for curves

Attach head pulley

5. Position the head pulley in the desired position and fit it using a TORX®-key T40 and 27 Nm (see Fig. 94).

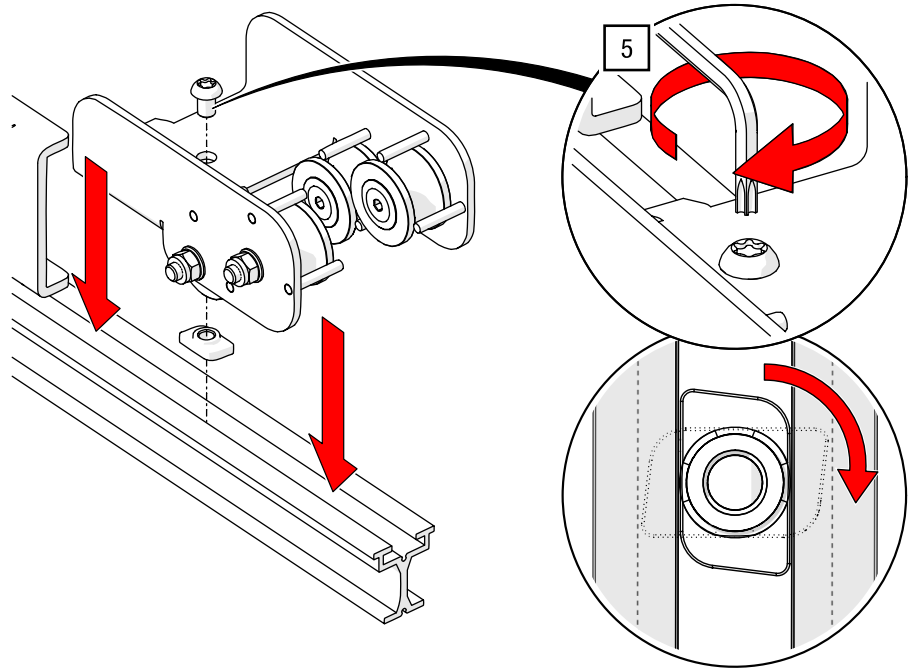

Fig. 108: Double top cord operation – Mounting the double top cord operation head pulley

Thread on the Runner and master runner and close the track

6. Close the track on one side with an end stop in accordance with *chapter 5.2.4 TRUMPF 95 end stop* [► p. 49].
7. Push the runners and master runner onto the track in the order corresponding to the project.
8. Close the second end of the track as described in *chapter 5.2.4 TRUMPF 95 end stop* [► p. 49].
9. In the case of a two-part curtain, push the runner and master runner together as far as possible in the stowage area on each side (see Fig. 109).

Insert the first side of the cord

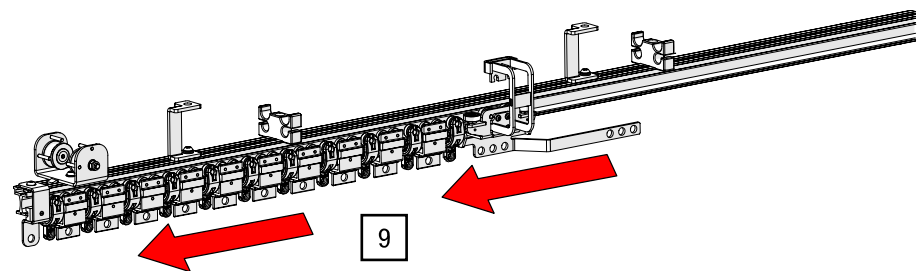

Fig. 109: Double top cord operation – Push the trolleys together

10. Pass the cord upwards on the left-hand side through the head pulley (see Fig. 110).
11. Guide the cord past the first master runner through the upper rollers of the cord guides (see Fig. 110).

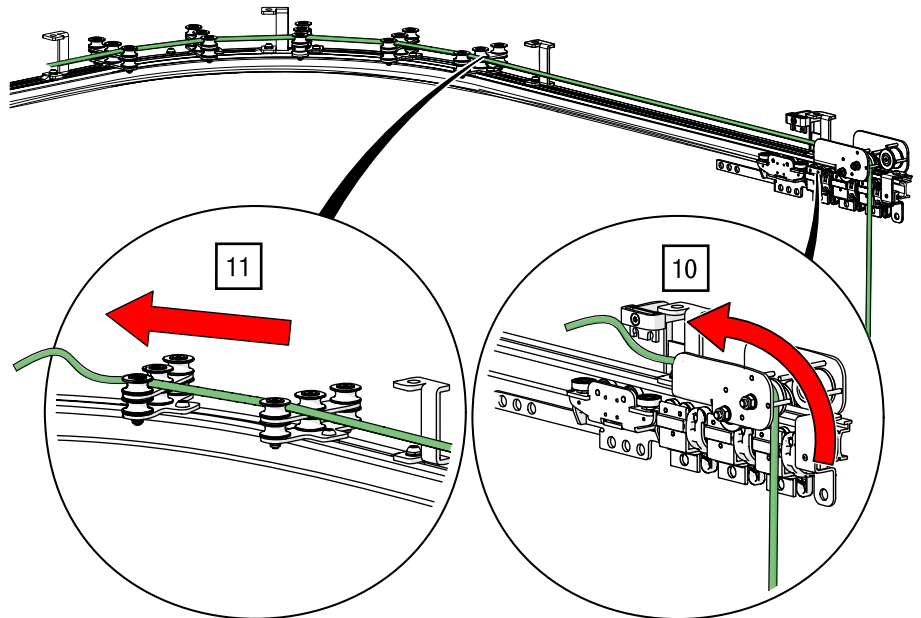

Fig. 110: Double top cord operation – Guide cord through head pulley and cord operation

12. Guide the end of the cord through the following cord guides and into the clamping unit on the master runner on one side and secure it with four tie wraps (see Fig. 111).

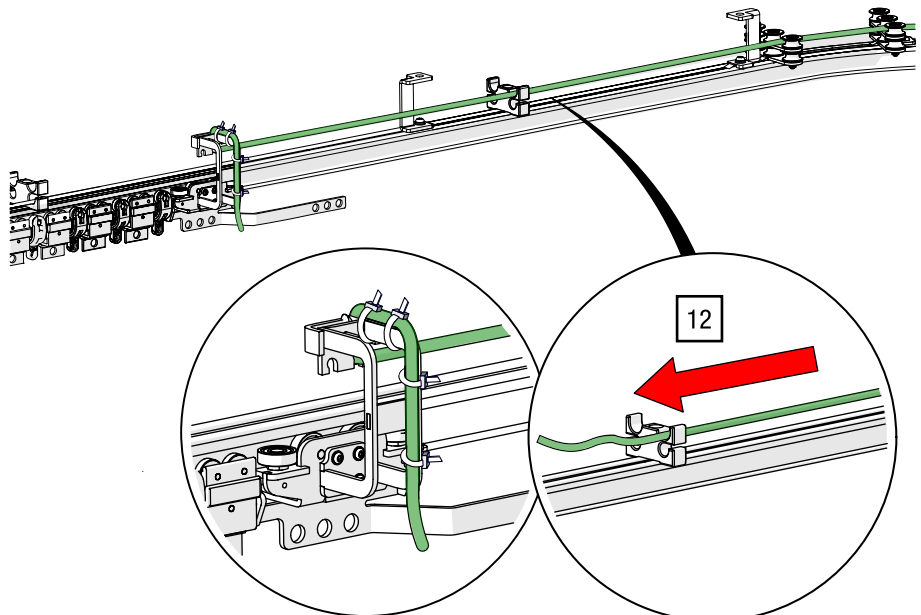

Fig. 111: Double top cord operation – Cord guide on one side in master runner

Insert second cord end

13. Attach a cord drive designated for your track system below the head pulley in accordance with *chapter 5.5 Installing manual rope drives* [► p. 88].
14. Pass the cord on the left-hand side through the head pulley upwards through the cord operations (see Fig. 112).

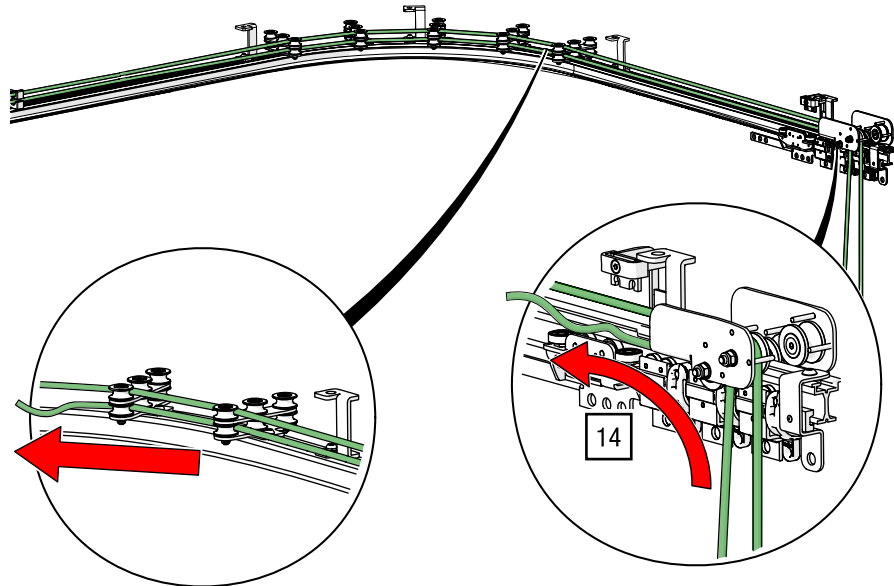

Fig. 112: Double top cord operation – Guide the second end of the cord through the head pulley and guides

15. Guide the second end of the cord through the return pulley into the master runner (see Fig. 113).

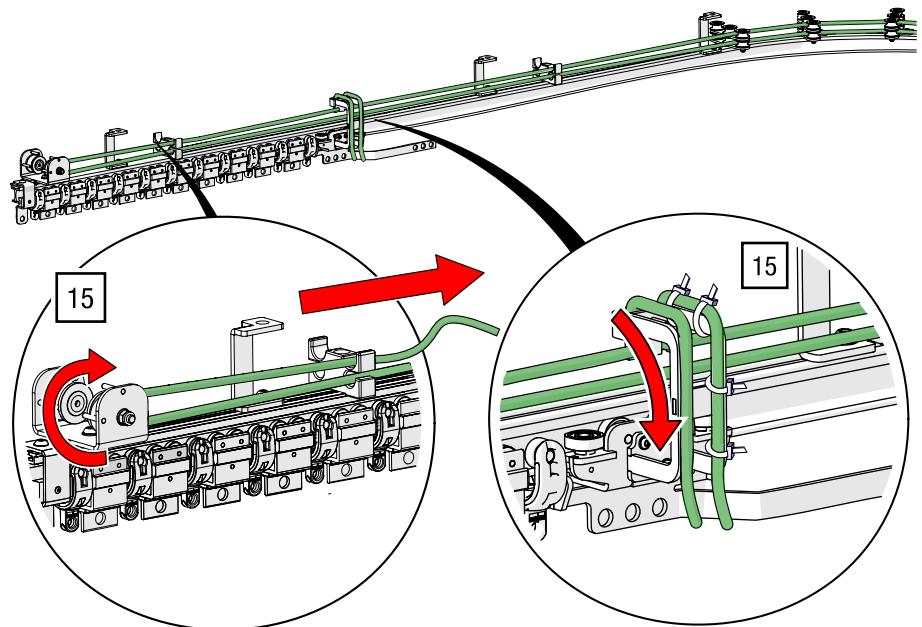

Fig. 113: Double top cord operation – Guide the end of the cord through the return pulley into the master runner

16. Clamp both cord ends in the second master runner using a TORX®-key T30 and 11 Nm and tie them tightly at several points on the master runner using four tie wraps in the same way as for the top cord operation at Fig. 102 [► p. 80].



Make sure there is enough length left after cutting the rope ends to readjust the cord operation system, if necessary.

17. Cut off the ends with a wire cutter (tool) and trim them as described for the top cord operation at Fig. 102 [► p. 80].

For installation of second cord course

- ➔ Activate steps 9 to 17 on the opposite side.

5.5 Installing manual rope drives

5.5.1 HAND-DRIVE

Materials / tools required

Quantity	Materials / Tools
1	HAND-DRIVE Item no. 31000 07091
Corresponding number of suspensions	Mounting material suitable for the substrate: <ul style="list-style-type: none"> E.g. drive-in anchor E M10 × 40 If in doubt, contact Gerriets GmbH (see <i>chapter 13.1 Contact us</i> [▶ p 122]).
1	TORX®-key T30 (not included)

Tab. 23: Manual drive HAND-DRIVE – Materials and tools required

Assembly

1. Screw the cord drive to the wall using the appropriate mounting material for the surface (assembly according to the manufacturer's instructions; example concrete wall – see Fig.114).

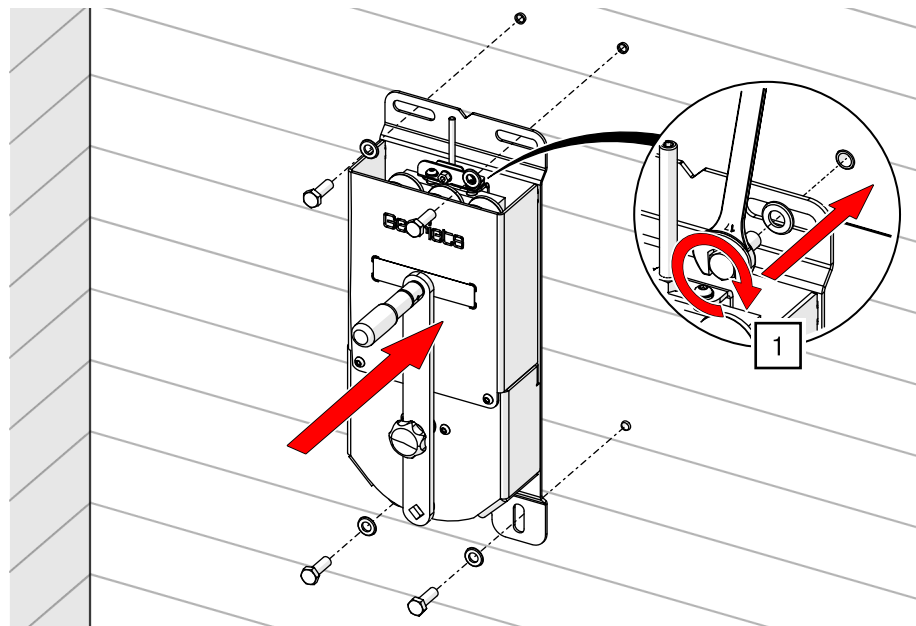

Fig.114: Screwing the HAND-DRIVE to the wall



The notch on the top of the housing can be used for alignment. Ensure that the cord course is as straight and direct as possible.

2. Loosen the housing screws on the top cover plate using a TORX®-key T30 and lift it out of its anchoring (see Fig. 115).

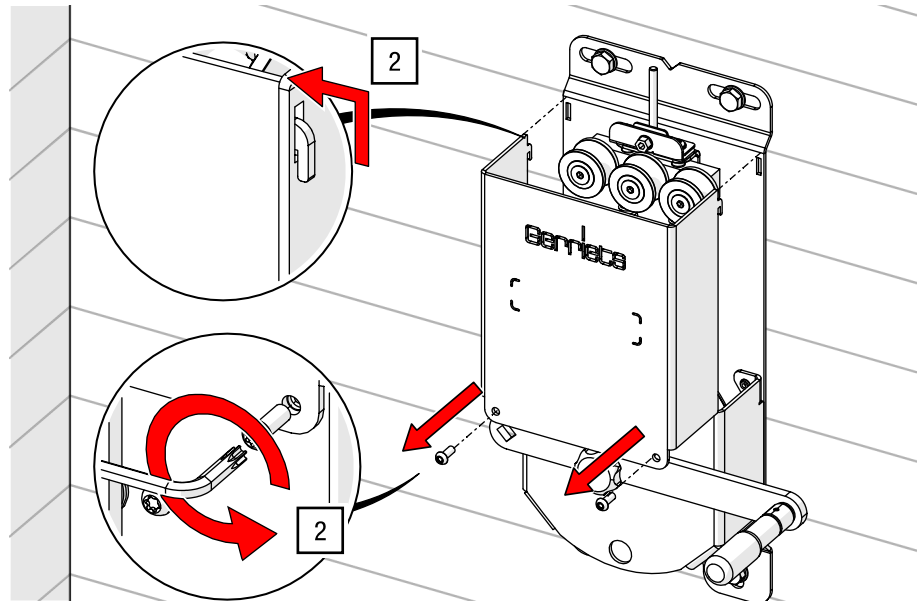

Fig. 115: Loosen the housing screws and open the housing

Assembly of the operating cord

3. Insert the 8 mm operating cord in the same way as described in *chapter 5.5.3 Traction cord installation on double-groove traction disc* [► p. 97].

Close housing

4. Close the housing in reverse order to step 2 (reverse to Fig. 115).

5.5.2 ROPE-DRIVE

Materials / tools required

Quantity	Materials / Tools
1	ROPE-DRIVE Item no. 31000 07101
1	Hemp rope floor pulley 350 Item no. 31000 07051
1 (alternative)	Hemp rope pulley for weighting sandbag Item no. 31000 07067
1	Mounting material suitable for the floor: <ul style="list-style-type: none"> E.g. concrete/screed: M6 drive-in anchor
1	TORX®-key T40 (not included)
1	Open-end wrench AF 19 (not included)

Tab. 24: ROPE-DRIVE manual drive – Materials and tools required

Assembly of ROPE-DRIVE on track

Assembly material for step 1:

- 2 × hexagon head screw M8
- 2 × spring washer D8.1
- 2 × washer D8
- 1 × mounting plate
- 1 × heavy-duty slot nut

1. Loosely pre-assemble the mounting plate with two M8 hexagon head screws and the appropriate washers and spring washers and slide it onto the track profile directly upstage of the head pulley (see Fig. 116).

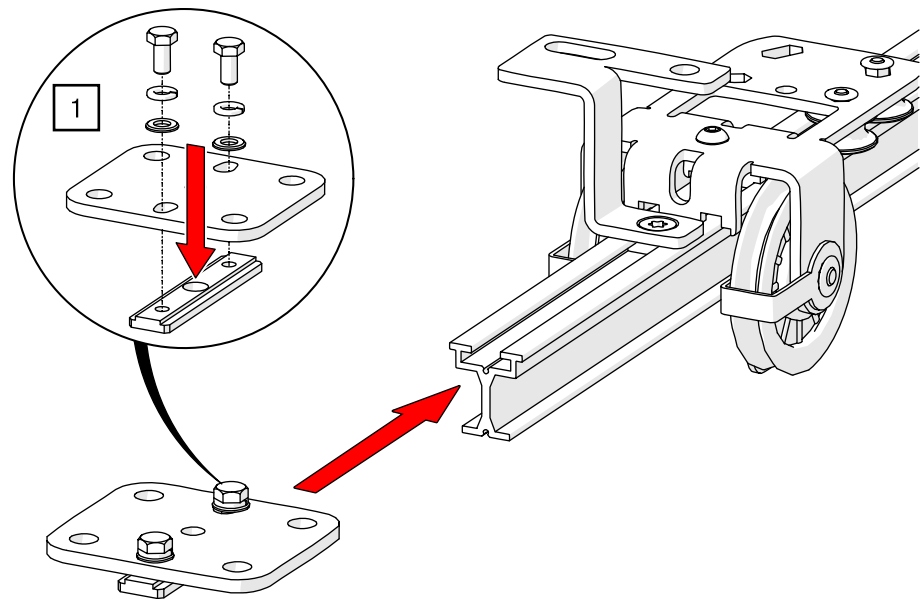

Fig. 116: Manual drive ROPE-DRIVE – Pre-assemble mounting plate

Assembly material for step 2:
 4 × hexagon head screw M12
 4 × spring washer D12.2
 4 × washer D12
 4 × nut M12

2. Screw the ROPE-DRIVE to the mounting plate and the mounting material using an open-end wrench AF 19 and 93 Nm (see Fig. 117).

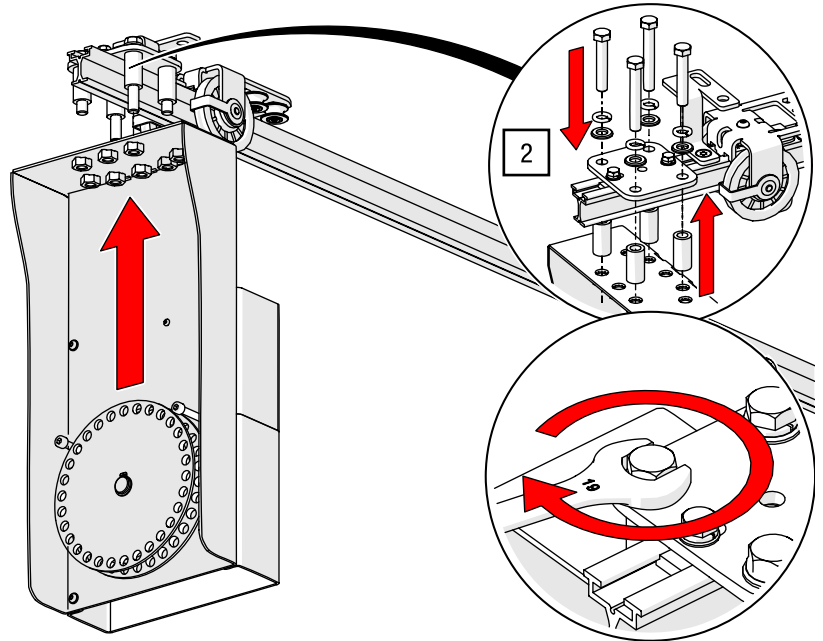

Fig. 117: Manual drive ROPE-DRIVE – Screw to mounting plate

3. Lock the screw connection from the inside with two M12 nuts and a 19 mm open-end wrench to 93 Nm (see Fig. 118).

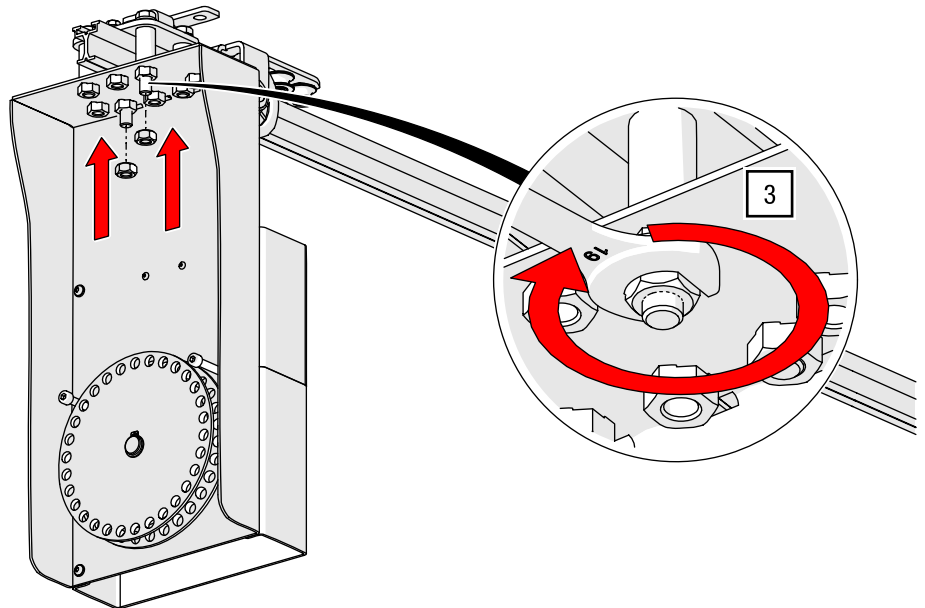

Fig. 118: Manual drive ROPE-DRIVE – Lock connection with mounting plate

Hemp rope floor pulley

4. Screw the hemp rope counter-tension pulley to the floor using mounting material suitable for the substrate (assembly according to manufacturer's instructions; example concrete floor / screed – see Fig. 119).

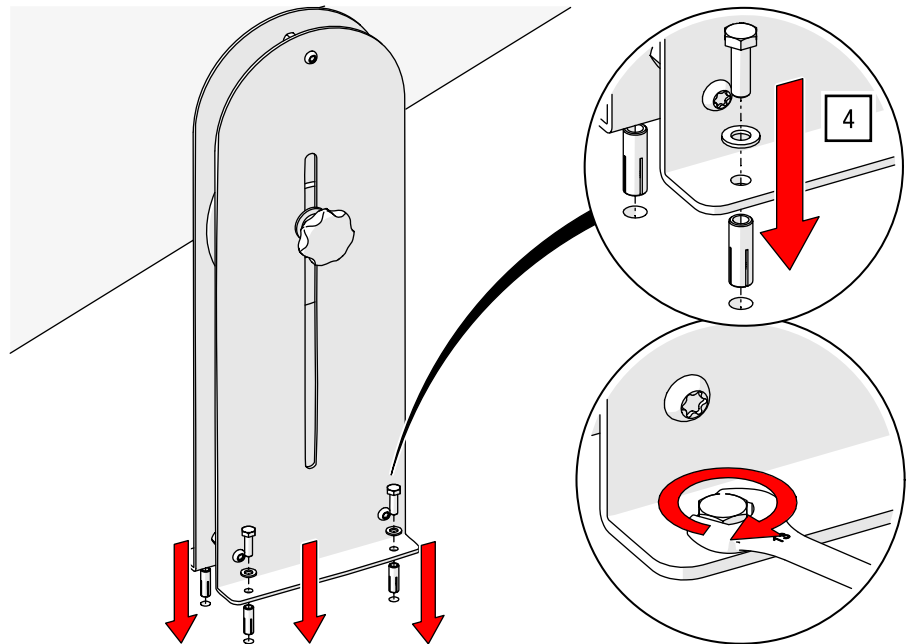

Fig. 119: Manual drive ROPE-DRIVE – Fitting the hemp rope floor pulley

5. Position the ROPE-DRIVE at the end of the track until the rope can be diverted as straight as possible from the head pulley to the tensioning unit of the ROPE-DRIVE and tighten the screws of the mounting plate with the open-end wrench AF 13 and 27 Nm.
6. Insert the 8 mm operating cord on the tensioning unit of the ROPE-DRIVE as described in *chapter 5.5.3* Traction cord installation on double-groove traction disc [► p. 97].

Assembly of the operating cord
(track side)

Assembly of the hemp rope (floor pulley or sandbag)

7. On the ROPE-DRIVE, loosen the two cylinder head screws adjacent to the hemp rope drive wheel using an Allen key AF 6 (see Fig. 120).
8. Place the hemp rope around the pulley located in the higher part of the ROPE-DRIVE housing (see Fig. 120).



This pulley sits on the same shaft as the traction disc for the operating cord.

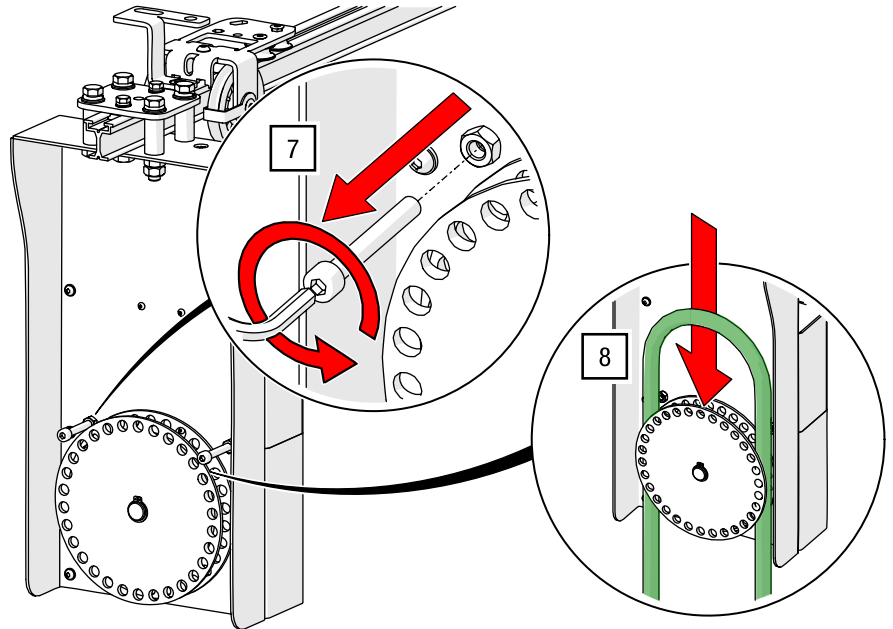

Fig. 120: Manual drive ROPE-DRIVE – Remove the rope lock and insert the hemp rope

9. Screw the cylinder head screws back in.

Hemp rope floor pulley

10. Revolve the screw connection of the hemp rope floor pulley on the star handles, pull out the axle screw, and remove the pulley (see Fig. 121).
11. Remove the long nut above the roller by loosening the two screws with a TORX®-key T40 (see Fig. 121).

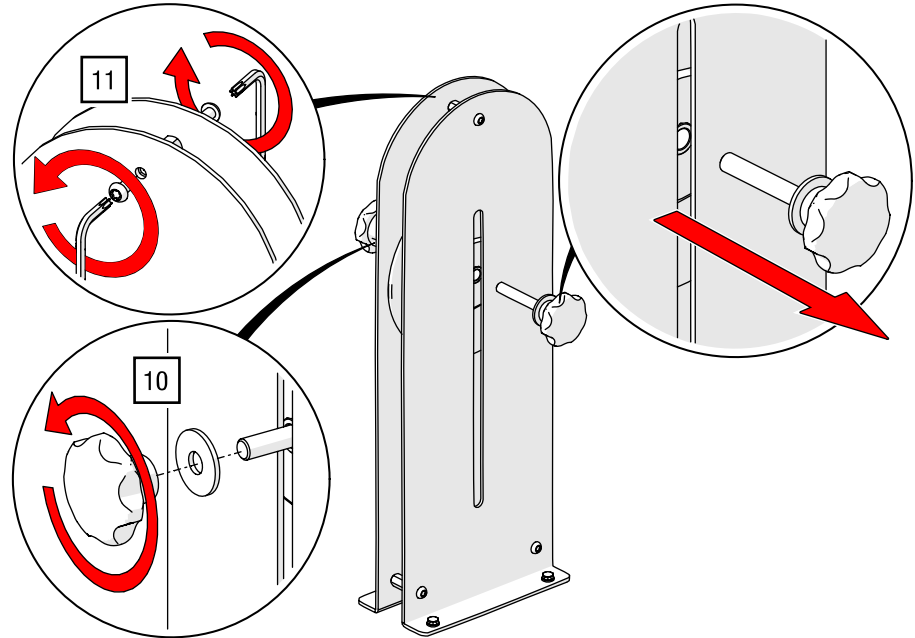

Fig. 121: Manual drive ROPE-DRIVE – Remove pulley from hemp rope floor pulley

12. Place the hemp rope around the pulley, insert the pulley into the housing, and loosely re-collect the axle with the star grips (see Fig. 122).

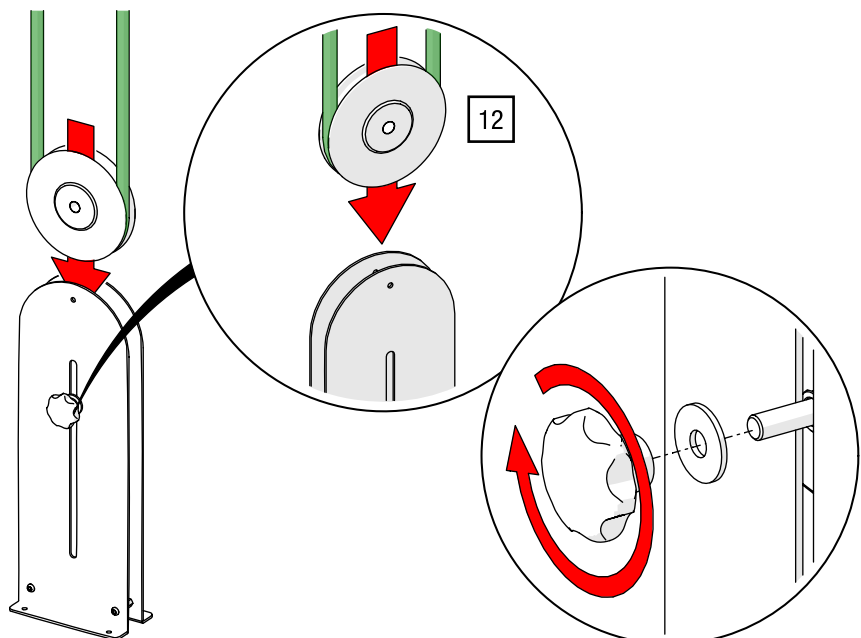

Fig. 122: Manual drive ROPE-DRIVE – Insert hemp rope and mount pulley

13. Refit the spacer above the roller by tightening the two screws with a TORX®-key T40 and 27 Nm (see Fig. 123).
14. Pull the star grips down until the desired cord tensioning is achieved and fix the star grips (see Fig. 123).

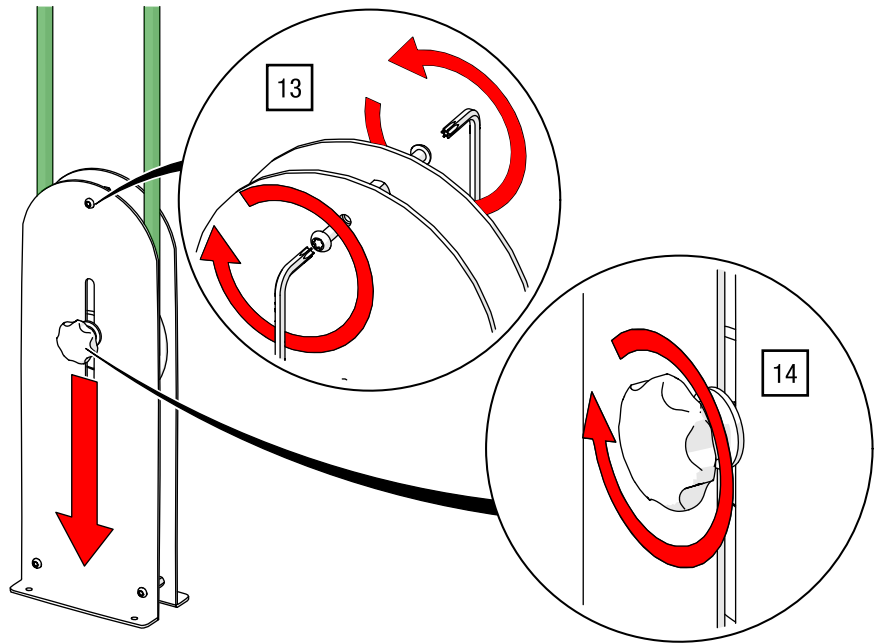

Fig. 123: Manual drive ROPE-DRIVE – Fit hemp rope pulley and tighten until tensioned

Alternative to the floor pulley:
hemp rope sandbag pulley

1. Loosen the roller from the housing by unscrewing the hexagon head screws with two open-end wrenches AF 19 and pull out the axle bolt (see Fig. 124).

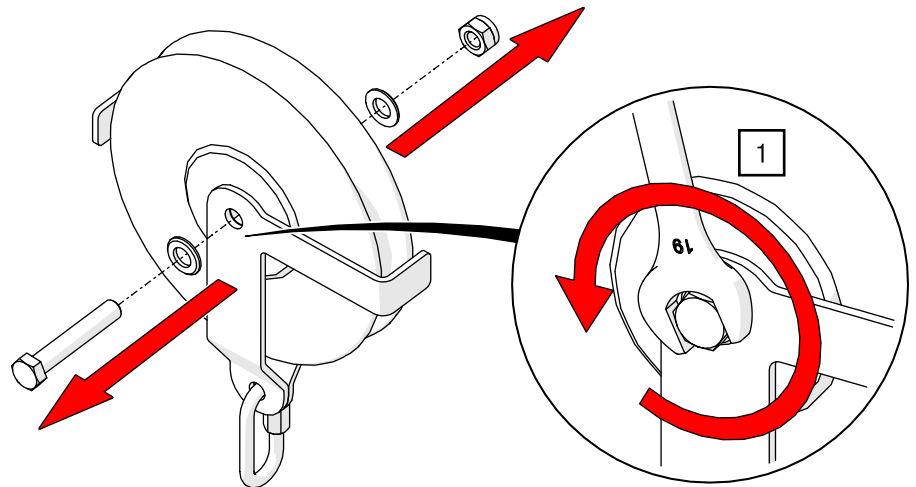

Fig. 124: Manual drive ROPE-DRIVE – Unscrew hemp rope sandbag pulley from housing

2. Place the hemp rope on the pulley and refit it (see Fig. 125).

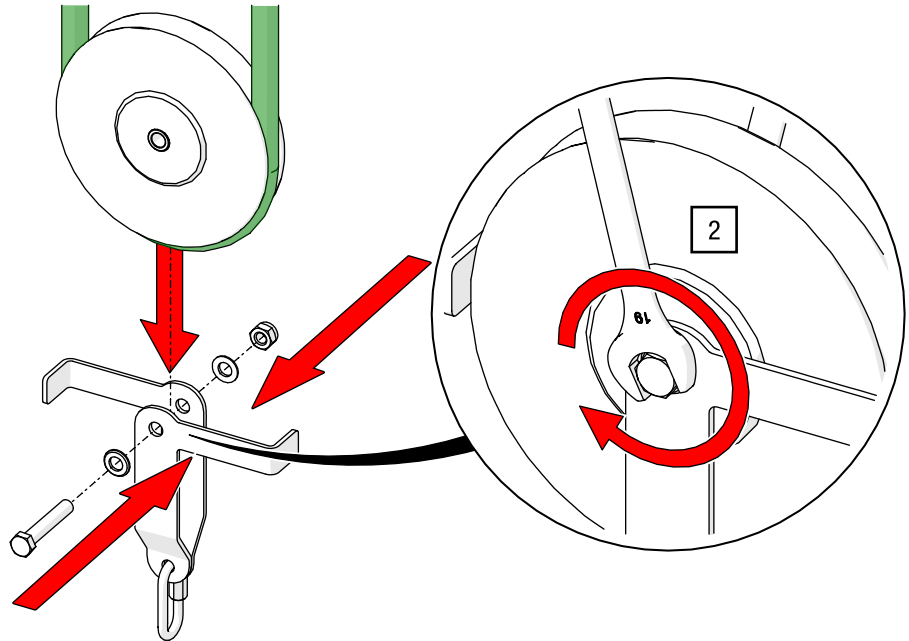

Fig. 125: Manual drive ROPE-DRIVE – For hemp rope sandbag pulley, insert rope and refit pulley

3. Hang a sandbag with sufficient counterweight to tighten the hemp rope on the chain quick-release fastener.

5.5.3 Traction cord installation on double-groove traction disc

Use threaded screws to move the cord guides into the cord installation position

1. Adjust the tensioning unit of the manual drive to its lowest position against the spring pressure. To do this, carefully turn the threaded rod located in the centre above the cord guides using an Allen key AF 5 (low torque with a cordless screwdriver) (see Fig. 126).

NOTICE: Damage to the plastic wheel due to incorrect setting on the cordless screwdriver.

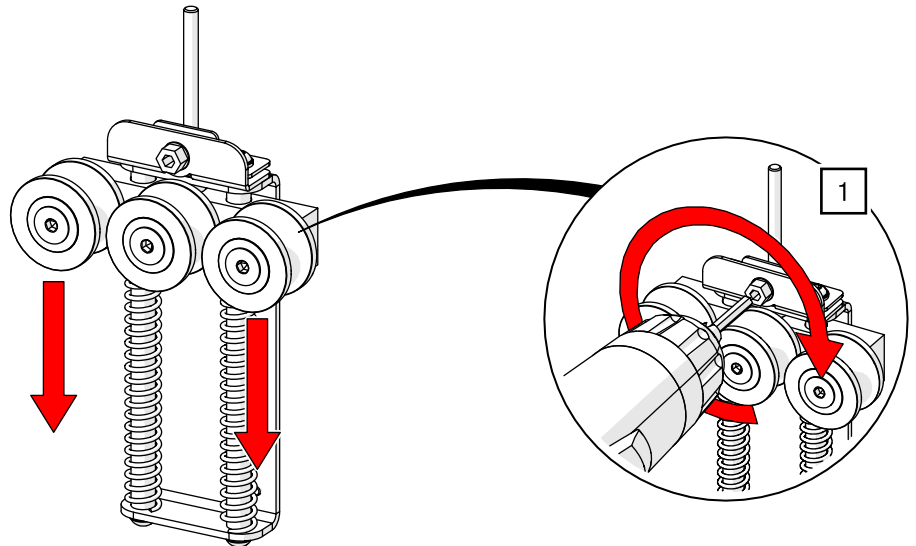

Fig. 126: Lower the cord guides

Insert the cord

2. Guide the operating cord, which is coming out of the operating cord system, over the inner side of the right tensioning unit guide onto the inner groove of the traction disc (see Fig. 127).
3. Guide the operating cord further around the central tensioning unit guide back to the traction disc (see Fig. 127).

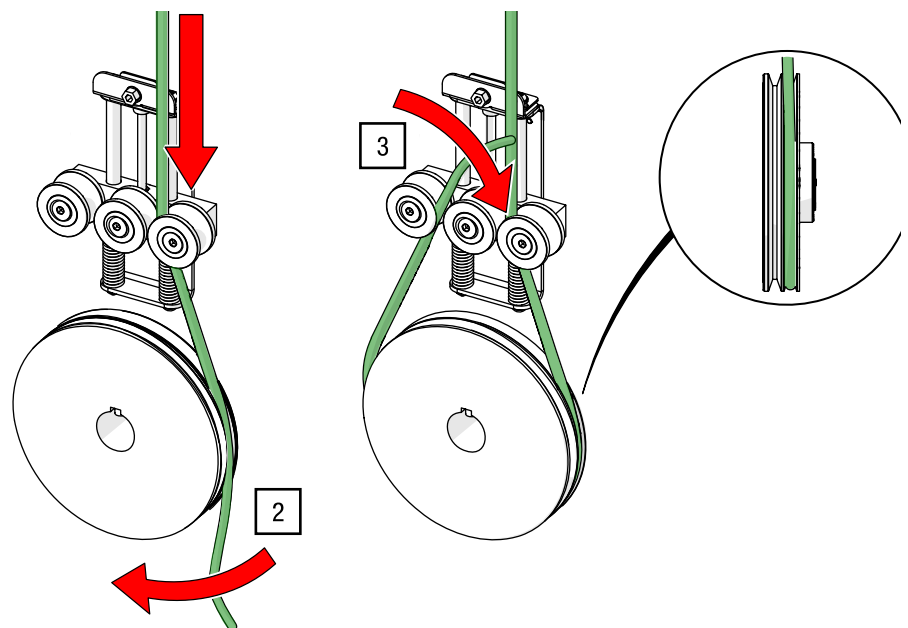

Fig. 127: Guide the cord around the inner groove of the traction disc

4. Guide the operating cord up over the outer groove of the traction disc (see Fig. 128).
5. Guide the operating cord up passing the left guide of the tensioning unit and over the head pulley back into the operating cord system and attach it on your master runner (see Fig. 128).

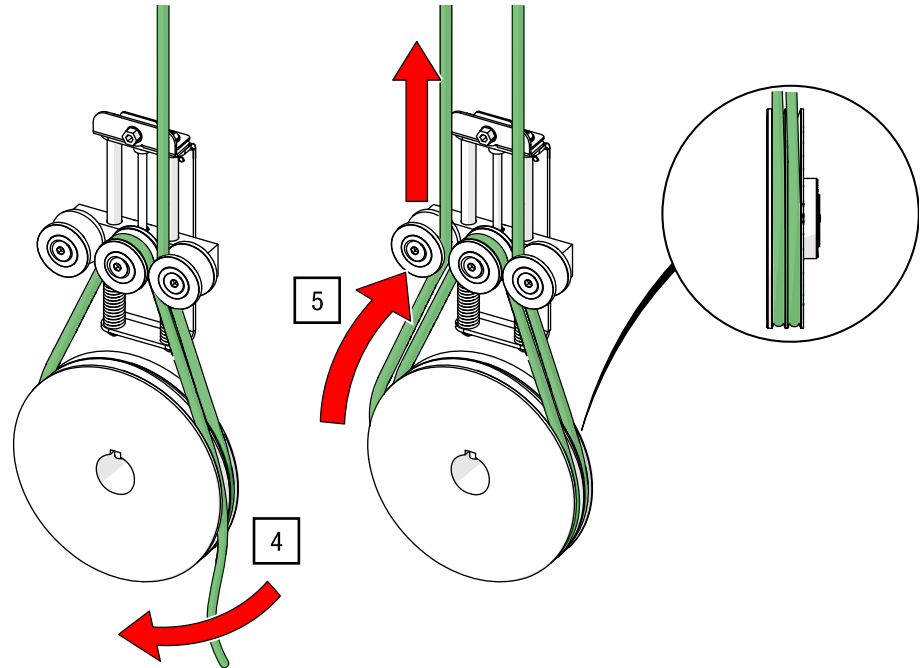

Fig. 128: Guide the cord around the outer groove of the traction disc

6. Carefully loosen the threaded rod with an Allen key AF 5 (low torque with a cordless screwdriver) until it can be revolved loosely (reverse to step 1; see also Fig. 126).

NOTICE: Damage to the plastic wheel due to incorrect setting on the cordless screwdriver.



By unscrewing the threaded rod, the spring pushes the guide rollers upwards and tensions the operating cord.

Loosening the cord tensioning to remove the operating cord

- ➔ Revolve the threaded rod until the spring no longer holds the cord under tension.

5.5.4 Floor pulley (polyester cord)

Materials / tools required

Quantity	Materials / Tools
1	Adjustable floor pulley 180/350 <ul style="list-style-type: none"> • 180 – Item no. 31000 07071 • 350 – Item no. 31000 07081
1	Mounting material suitable for the floor: <ul style="list-style-type: none"> • E.g. concrete/screed: Drive-in anchor E M6
1	Tool e.g. open-end wrench (not included)

Tab. 25: Adjustable floor pulley – Materials and tools required

Assembly

1. Screw the floor pulley to the position exactly vertically below the cord outlet of the track on the floor using assembly material suitable for the substrate (assembly according to manufacturer's instructions; example concrete / screed – see Fig. 129).

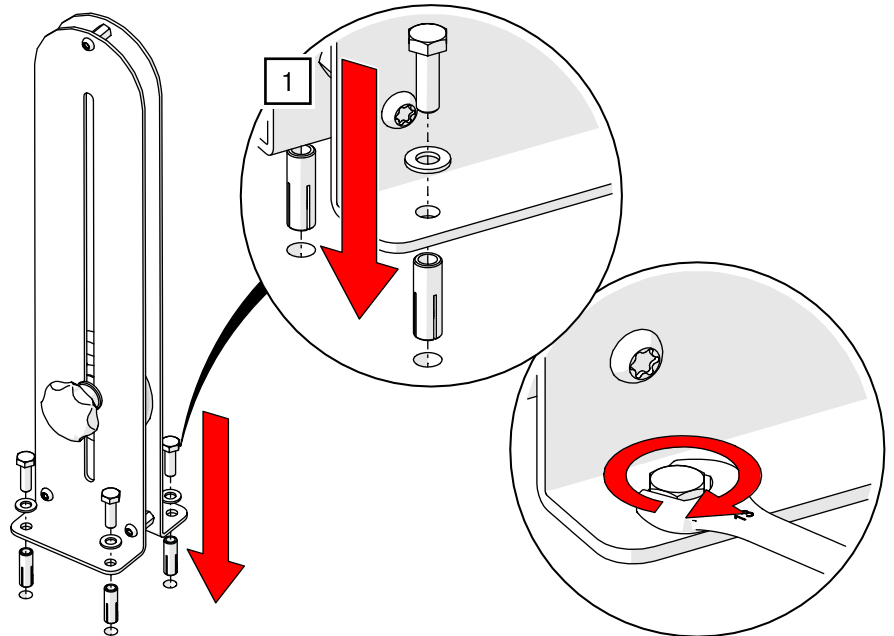

Fig. 129: Manual drive – Fitting the floor pulley

2. Position the roller by loosening the two star screws and tightening them at the uppermost point.
3. Guide the cord through the pulley and completely through the track layout according to the cord guide variant (see *chapter 5.4 Installing the cord operation system* [▶ p. 65]).
4. Loosen the star screws, press the pulley down on the star screws until the desired cord tensioning is achieved and tighten them hand tight.

5.5.5 Hemp rope pulley for weighting sandbag

Materials / tools required

Quantity	Materials / Tools
1	Hemp rope pulley for sandbag weighting Item no. 31000 07067
1	Sandbag (not included)
1	Hemp rope (max. Ø 22 mm rope; according to order)

Tab. 26: Hemp rope pulley for weighting sandbag – Materials and tools required

Assembly

1. Guide the rope through the hemp rope pulley for sandbag weighting.
2. Hang the chain quick-release fastener in the mounting hole of the floor pulley.
3. Take the load off the rope by positioning the floor pulley on a raised work surface that corresponds to the working height.
4. Guide the hemp rope upwards completely through the track system (see *chapter 5.4 Installing the cord operation system* [► p. 65]).
5. Hang the sandbag freely and with sufficient weight to tension the hemp rope in the chain quick-release fastener and close the chain fastener securely.

5.5.6 Stirrup floor pulley with foot stirrup

Materials / tools required

Quantity	Materials / Tools
1	Stirrup floor pulley with foot stirrup Item no. 31000 07061
1	Polyester cord (according to order)
1	Raised shelf (not included)

Tab. 27: Stirrup floor pulley with foot stirrup – Materials and tools required

Assembly

1. Guide the cord through the floor pulley.
2. Take the load off the cord by positioning the pulley on a raised work surface that corresponds to the working height.
3. Guide the cord upwards through the track system (see *chapter 5.4 Installing the cord operation system* [► S. 65]).

5.5.7 Self-tensioning floor pulley with counterweight

The self-tensioning floor pulley with guide sleeve is used for automatic tensioning of the manual rope drives.

The guide sleeve ensures safe, linear guidance of the weight body.

Materials / tools required

Quantity	Materials / Tools
1	Self-tensioning floor pulley with counterweight Item no. 31000 07011
1	Mounting material suitable for the floor: <ul style="list-style-type: none"> E.g. concrete/screed: Drive-in anchor E M6
1	Tool e.g. open-end wrench (not included)

Tab. 28: Self-tensioning floor pulley with counterweight – Materials and tools required

Assembly of the guide cage

1. Fasten the guide sleeve of the self-tensioning floor pulley vertically below the downward guide pulley using mounting hardware suitable for the supporting structure (installation according to the manufacturer's instructions; example: concrete/screed – see Fig. 130).

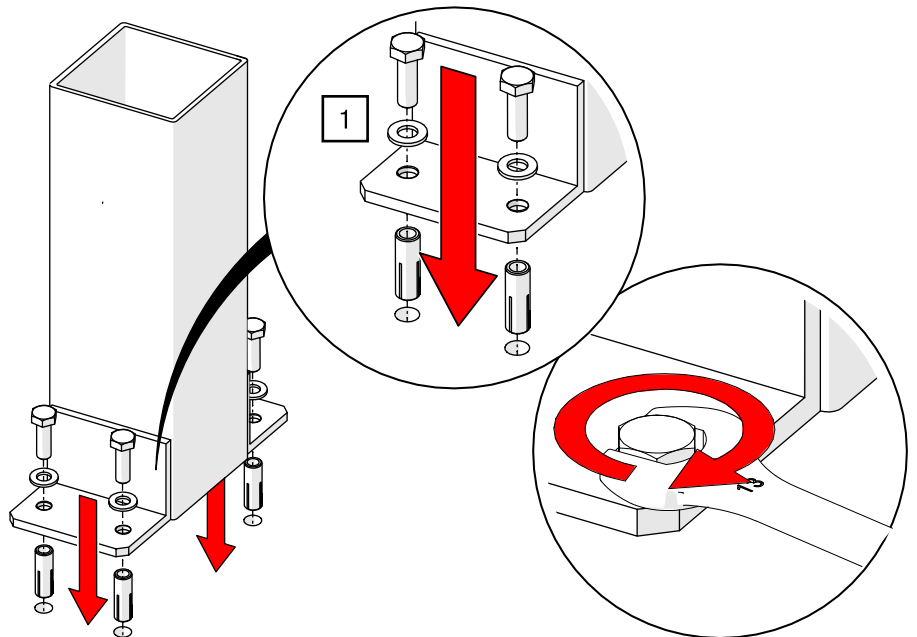

Fig. 130: Self-tensioning floor pulley with counterweight – Fastening the guide sleeve

2. Place the self-tensioning floor pulley on a raised work surface that is at least the height of the guide basket.
3. Feed one end of the cord coming from the downward guide pulley towards the tension pulley bracket.

Insert the cord

4. Route the cord through the pulley and guide it back up into the downward guide pulley, then along the track according to the selected cord-routing variant (see Fig. 131 and *chapter 5.4 Installing the cord operation system* [► p. 65]).
5. Insert the counterweight into the guide sleeve (see Fig. 131).

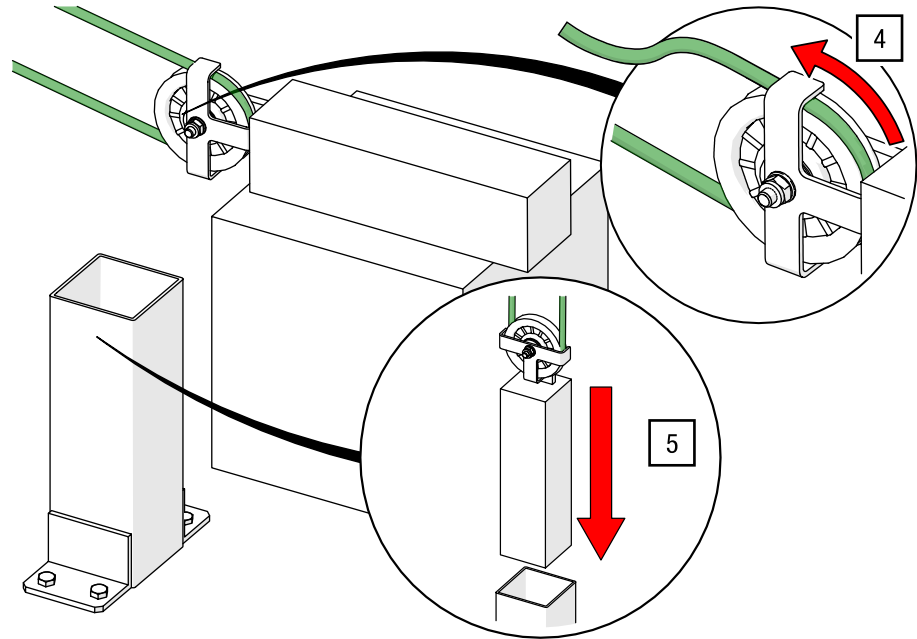

Fig. 131: Self-tensioning floor pulley with counterweight – Routing the cord and inserting the counterweight into the guide sleeve

5.6 Installing the track switch



Four \varnothing 10.5 mm holes are provided in the stile of the track switch for suspension from the ceiling or a substructure.

All four suspension points must be used to ensure a stable position of the track switch in any operating state.

5.6.1 Ceiling mounting (manual/electrical)

Different mounting methods can be used depending on the ceiling construction and suspension. The direct assembly of the track switch with drop-in anchor to the concrete ceiling is shown below.

Materials / tools required

Quantity	Materials / Tools
1	Manual track switch: <ul style="list-style-type: none"> • 1 on 2 – Item no. 31150 01101 • 1 on 3 – Item no. 31150 01111 • 2 on 3 – Item no. 31150 01131 Electrical track switch: <ul style="list-style-type: none"> • 1 on 2 – Item no. 31150 01141 • 1 to 3 – Item no. 31150 01151 • 2 on 3 – Item no. 31150 01171
Number of track sections to be connected accordingly	TRUMPF 95 track splice <ul style="list-style-type: none"> • Item no. 31150 00061
1	Mounting material suitable for the ceiling and suspension: <ul style="list-style-type: none"> • E.g. concrete/screed: Drive-in anchor E M10
1	TORX®-key T20 (not included)

Tab. 29: Track switch – Materials and tools required



A drilling template can simplify the screwing process (see step 1).

Track switch assembly

1. Screw the track switch to the ceiling using the appropriate mounting material for the substrate (assembly according to the manufacturer's instructions; for example, concrete – see Fig. 132).

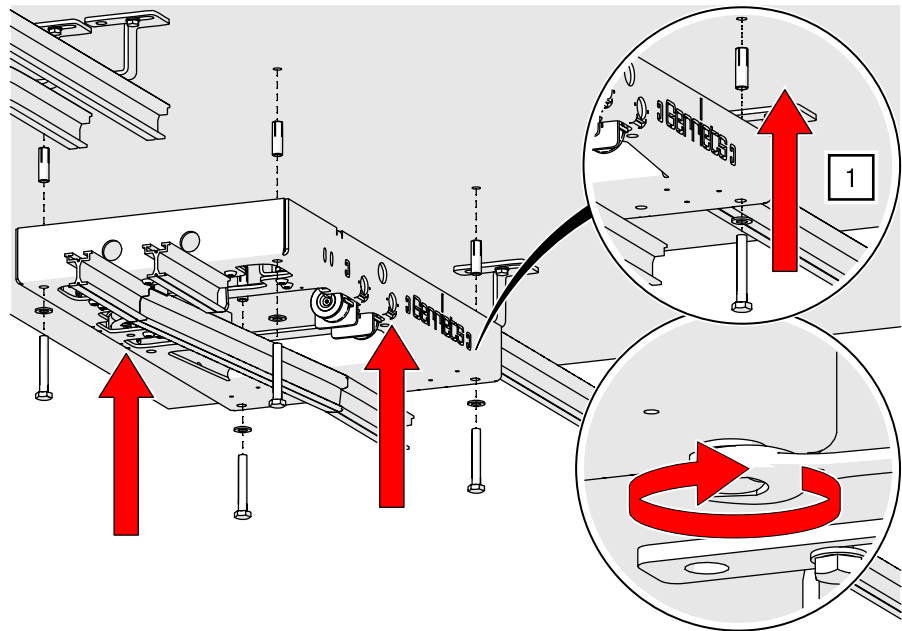

Fig. 132: Track switch – Ceiling mounting

2. Fit the first track section to the track switch using the track splice supplied in accordance with *chapter 5.2.1 Track splice* [► p. 42] (see also Fig. 133).
3. Align the other track ends one after the other so that they are aligned with the corresponding track end of the track switch (see also Fig. 133).
4. Install the other track splices one after the other as described in step 2.

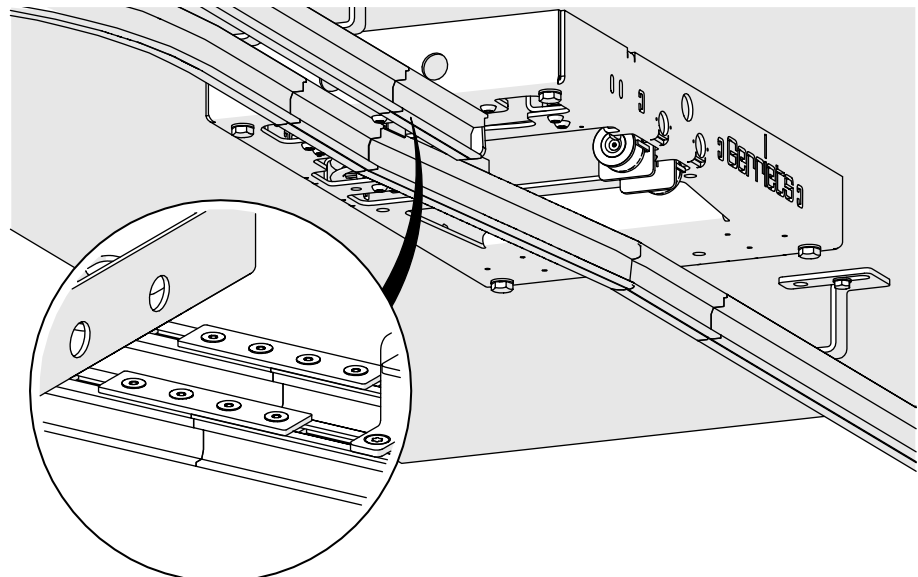

Fig. 133: Track switch – Connect track switch to track system

Only manual track switch:
operating cord assembly

5. Loosen the clamping plate on the cord plate of the switch finger using a TORX®-key T20 (see Fig. 134).

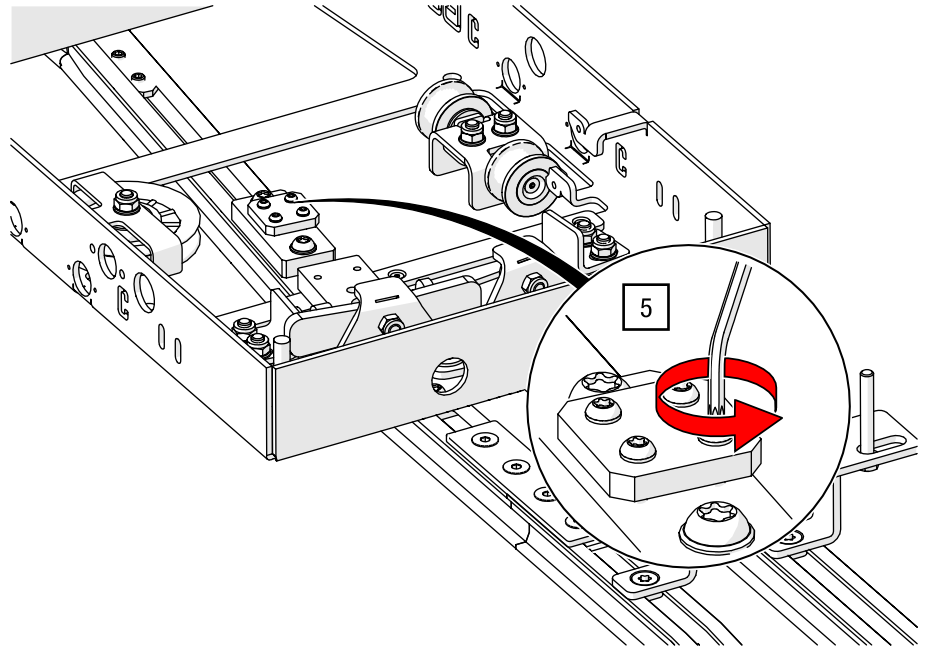

Fig. 134: Track switch – Release clamping plate

6. Guide the polyester cord upwards (1) over the head pulley, through the loosened clamping plate and through the return pulley (2; see Fig. 135).

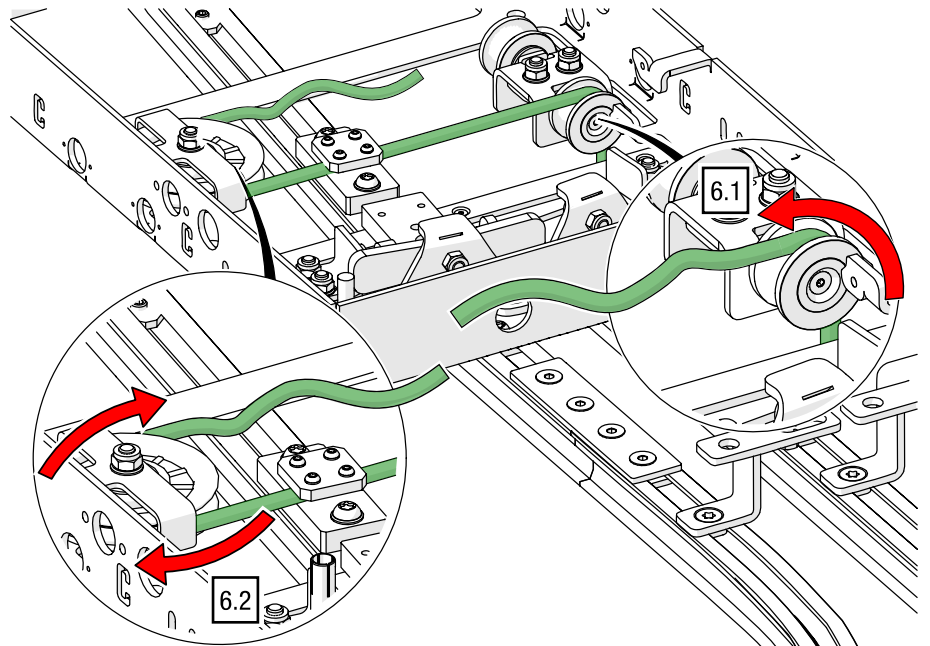

Fig. 135: Track switch – Guide the cord upwards and through the return pulley

7. Guide the cord down through the head pulley (see Fig. 136).
8. Cut off the ends at a comfortable working height (approx. 1.1 m) using a wire cutter (tool) and burn the freshly cut surfaces, so that the rope does not unravel (see Fig. 136).

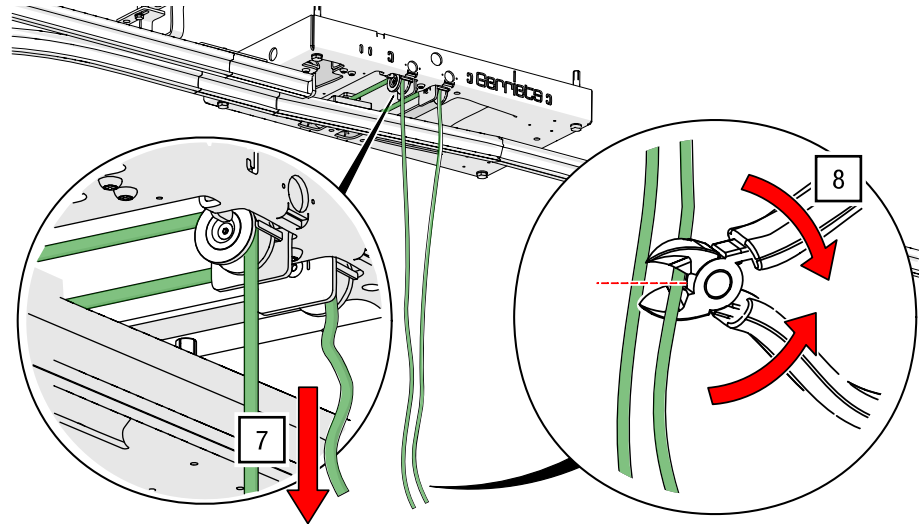

Fig. 136: Track switch – Guide cord down and cut off

Knots or wooden handles

9. Fix the cord to the clamping plate with a TORX®-key T20 and 3 Nm.
 - ➔ If desired, the end of the cord can be made into a knot or fitted with wooden handles for better handling.

5.6.2 Electrical connection

Notes on
safety



DANGER

Danger to life due to electrical voltage

There is a danger to life from high voltages when working on the electrical installation.

- The electrical installation (connection of the control system to the power supply) may only be conducted by a qualified electrician. It must be conducted in accordance with the wiring diagram.
 - Ensure that the system is de-energised before working on and in the terminal box.
 - Only have work on the electrical installation conducted by qualified specialists.
 - If the power supply is damaged, disconnect it immediately and have it repaired in accordance with the wiring diagram.
 - Keep moisture away from live parts.
 - Never bypass the fuses or put them out of operation.
-

Mechanical assembly

- Install the electrical track switch according to *chapter 5.6.1 Ceiling mounting* [► p. 103] on the concrete ceiling or according to the ceiling construction.
-

Electrical assembly



The track switches are completely pre-wired at the factory. You only need to connect the plugs. If no plug connection is provided on the control side, lead the cable into the control housing and connect it according to the wiring diagram.

- The track switch and control system are connected by a qualified electrician in accordance with the enclosed wiring diagram.
- After completing the electrical installation, evaluate the functions of the track switch. Assess all intended positions.

6 Operation

6.1 HAND-DRIVE

Movement of the operating cord and the suspended load

1. Fold the handle into the horizontal position (see Fig. 137).
2. Revolve the crank handle to move the attached loads via the operating cord (see Fig. 137).
3. Change the direction of rotation of the crank to move the load in the opposite direction.

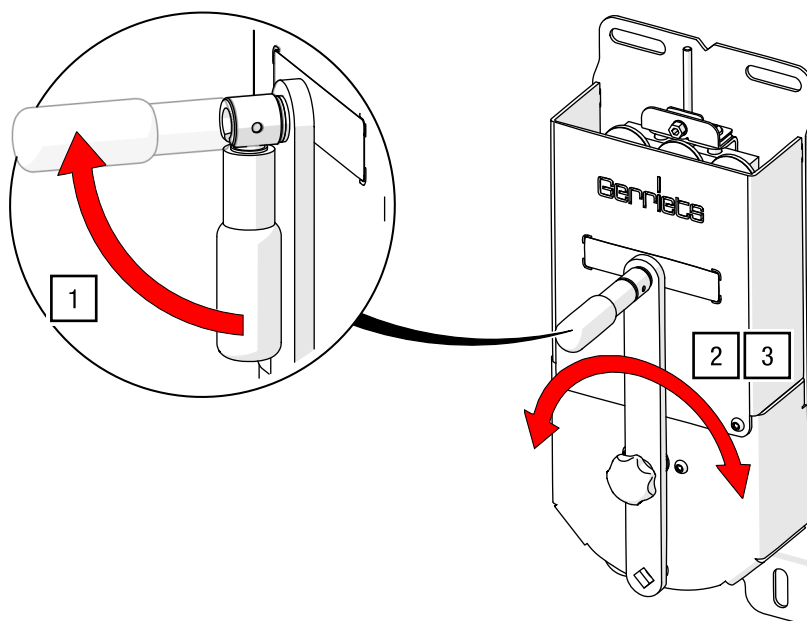

Fig. 137: HAND-DRIVE – Folding and operating the handle



Turn clockwise to open the curtain. Turning anticlockwise closes the curtain.

Changing the crank ratio

1. Unscrew the star screw of the crank handle from the inner holder (item 1) of the crank arm and remove the crank arm from the fixing point (see Fig. 138).
2. Guide the outer holder of the crank arm over the fastening point (item 2) and re-tighten the fastening screw hand-tight (see Fig. 138).



Position 1 of the crank arm (short lever) enables faster movements of an attached load.

Position 2 of the crank arm (long lever) allows for easier power transmission and is therefore used for heavier loads.

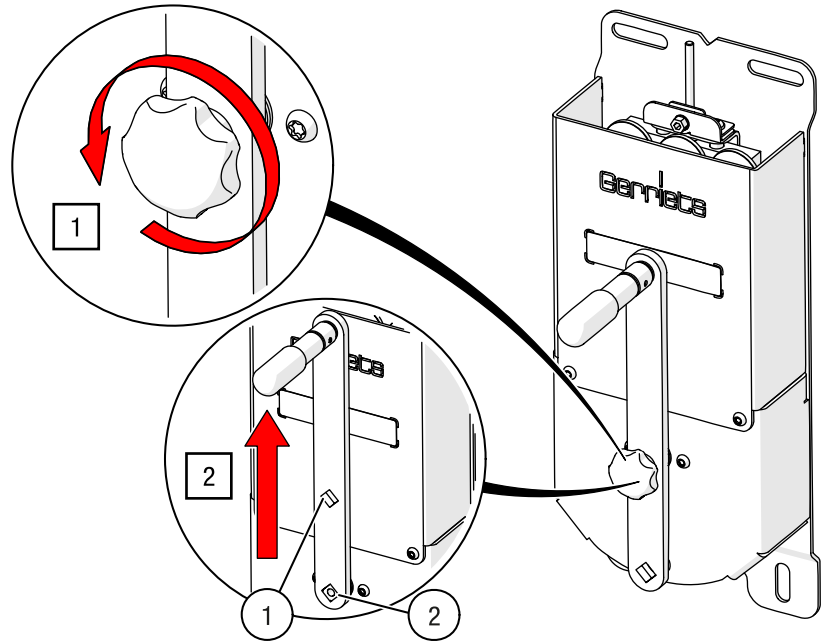

Fig. 138: HAND-DRIVE – Changing the crank ratio

6.2 ROPE-DRIVE

1. Depending on the desired direction of travel of the attached load, pull the hemp rope down on the left or right side (see Fig. 139).

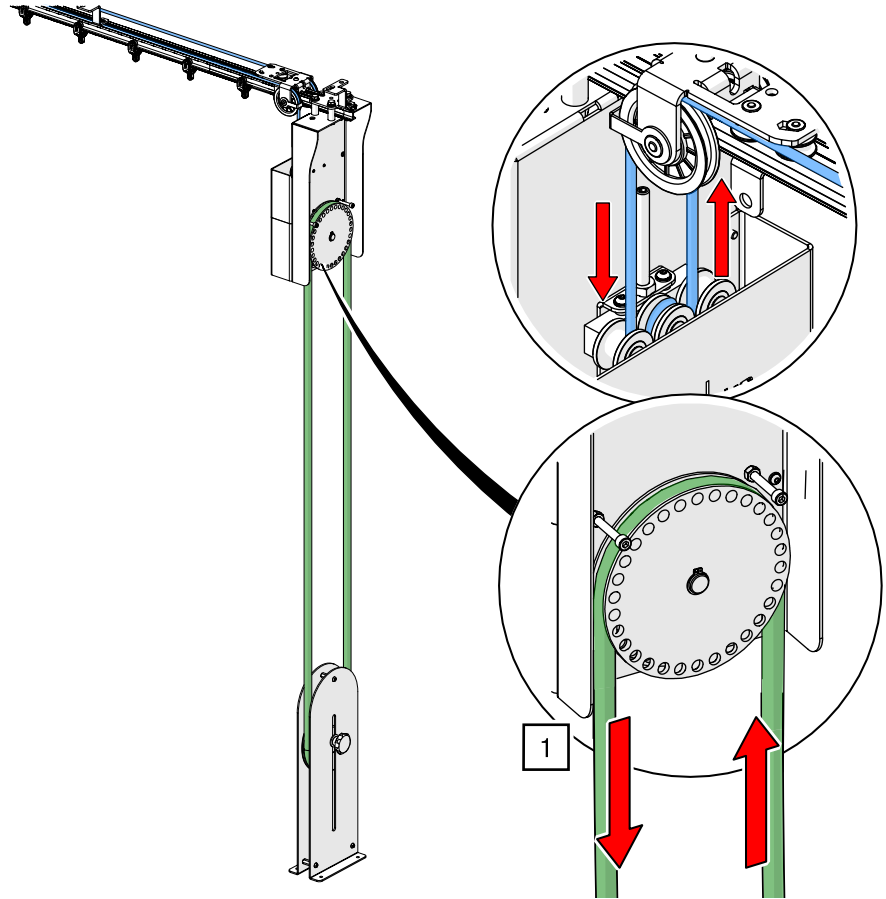

Fig. 139: ROPE-DRIVE – Operation

6.3 Track switch

6.3.1 Manual operation

1. Make sure that there is no load on the switch finger under any circumstances when the track switch is in operation.
⚠ WARNING: If the track switch is set to an intermediate position, the load can run off the track and cause severe injury.
2. Pull the track switch finger with the cord ends to the desired end position of the track.
3. Pull the curtain or backdrop material over the track switch onto the corresponding track section.

6.3.2 Electric operation

1. Unlock the emergency stop button if it was previously pressed.
2. Press the “Main circuit breaker” or “On / Off” button.
If your system has a key switch, turn the key to the “On” position.
3. Make sure that there is no load on the track switch finger.
Press the button for the position you want to move to.
⇒ The track switch moves to this position until the limit switch / position switch activates.
4. To cancel an initiated movement, press the “Stop” button.
5. By pressing a position button, you can continue the initiated movement or move to a different position.



By switching off the control system and, if necessary, removing the key, you can prevent the track switch from being set in motion unintentionally or without authorisation.



The motor's self-locking gear holds the track finger in the approached position.

7 Maintenance and servicing

7.1 Proper maintenance



Regular maintenance in accordance with the maintenance schedule is a prerequisite for efficient and safe use of the track system.

- ➔ Follow the maintenance instructions.
- ➔ Conduct maintenance and servicing work regularly to ensure trouble-free operation over the product's service life.
- ➔ Reinsert screw connections in accordance with the specific assembly instructions and locking elements (e.g. rings, pins, and clips) and check their effectiveness.

7.2 Maintenance schedule

Maintenance measure	Before each use	quarterly	half-yearly	yearly
Check all screw connections for tightness			●	
Visual inspection: suspensions				●
Check castors for damage				●
Clean the track system to remove dust				●
Visual inspection of the electrical track switch and switch control unit: Are the cables and plug connections undamaged?		●		
Visual check of the track switch control unit: Are all display elements illuminated?	●			
Switch control test: Electrical system and control system				●
Track switch: Status of the switch finger				●

Tab. 30: Maintenance table

Maintenance frequency
Varies according to use



Some work mentioned is highly dependent on usage and environmental conditions. The specified cycles are minimum values.
Different maintenance cycles are possible in individual cases.

- ➔ Correct deviating maintenance cycles.
- ➔ Instruct the operating personnel accordingly.

7.3 Storage

Short-term and medium-term storage (up to 2 years) is possible without extraordinary measures if the storage conditions correspond to the ambient conditions from *chapter 3.1 Ambient conditions* [► p. 32].

- ➔ For longer-term storage, take additional measures to protect against corrosion.
- ➔ Store the track system in a dry and dust-free place.
- ➔ Do not expose the track system to aggressive media.

8 Troubleshooting

8.1 Fundamentals



- In the event of interference whose cause you cannot determine and rectify yourself, shut down the system and contact Gerriets GmbH customer service (see *chapter 13.1 Contact us* [▶ p. 122]).
- Work on the electrical installation must be conducted by specialised personnel and, in particular, by Gerriets GmbH personnel during the warranty period.

NOTICE

Material damage due to improper modifications to the track system

The function and safety of the TRUMPF 95 track system may be impaired by improper additions or modifications.

- Do not make any changes or additions to the track system using non-original spare parts.
 - Always pay attention to the maximum load capacity (see load capacity tables in *chapter 3.2 Track system* [▶ p. 32]).
 - If in doubt, please contact us (see *chapter 13 Contact and warranty* [▶ p. 122]).
-

9 Decommissioning and disposal



If individual components of the track system are defective, we focus on sustainability and offer to repair them if this is possible.

We will be happy to check for you whether a repair makes sense. Contact us using the contact options in *the section 13 Contact and warranty* [► p. 122] or via the contact details for the locations on the back side.

9.1 Temporary shutdown

1. Secure the danger zone.
2. Start dismantling from the payload side and remove loads and load-bearing components in the power flow step by step.
3. Clean all components and store them in dry and dust-free containers or ideally in their original packaging.

9.2 Environmental protection, dismantling, and disposal

Environmental protection/WEEE



Dispose of the track system, components, and accessories at the end of their service life in an environmentally friendly manner in accordance with the applicable legal regulations.

Follow the national and international regulations. This applies primarily, but not exclusively, to metals, fibre composites, non-ferrous metals, and plastics. If in doubt, contact your local authority or a specialised waste disposal company to ensure proper disposal in accordance with environmental standards. They can provide you with information on the correct procedures and methods.

Packaging materials that are no longer required for storage or transport must be disposed of in an environmentally friendly manner.

Dismantling and disposal

1. Follow the steps from the previous *subchapter 9.1 Temporary shutdown* [► p. 115].
2. Dispose of all parts properly in accordance with local regulations.

10 Safety

10.1 Utilisation

10.1.1 Intended use

The TRUMPF 95 track system is designed for manual or motorised operation within its load-bearing capacity with medium-weight curtains and scenery for stage and studio applications, for complex track guides with track switches and for soundproof curtains (OFFICE).

To ensure that the TRUMPF 95 track system is assembled safely and as intended, it is essential to follow all the information and instructions in the installation manual.

- ➔ During assembly, reliably prevent unauthorised persons from entering the danger zone.

10.1.2 Foreseeable misuse

Any use other than that specified under the intended use is considered as improper use.

Consequences of non-compliance

Disregarding this operating manual may result in profound consequences of death, severe injury to persons and damage to the system or the property of third parties. These are not covered by the product warranty or liability.

- ➔ Please refer to *chapter 10.5 Disclaimer* [▶ p. 119].

Further examples of improper use

Examples of improper use include, but are not limited to

- Attaching attachments not approved by Gerriets and modifying the product.
- Unauthorised entry into the danger zone during assembly.
- Picking up and moving (“flying”) people.

10.2 General warnings

Fundamentals

The TRUMPF 95 track system complies with the latest technical standards and the applicable health and safety regulations.

Nevertheless, there is a risk of injury to the installer and third parties and of damage to property, particularly during assembly.

Mechanical dangers



DANGER

Risk of injury from falling objects and suspended loads

Falling objects can cause accidents resulting in death, severe injury or damage to property.

- Pay attention to the maximum load-bearing capacity of the overall system and individual components.
- Only install the system on a sufficiently load-bearing substrate or substructure.
- Avoid dynamic loads such as falls (“falling” of the load into the static system) or swinging movements.
- Do not do any changes, additions, or set changes to the track system unless these have been authorised in writing by Gerriets.
- Secure the danger zone.
- Secure loads to be fastened against falling during assembly (e.g. using suitable hoists).
- Always assemble the screw connections of the parts with the aid of the specific assembly instructions and tables for tightening torques.
- Always use securing elements such as rings, clips, and pins correctly and check their effectiveness.
- Check the mounting equipment for suitability and permissible load-bearing capacity before use.

10.3 Personnel and target group

10.3.1 Responsibility of the operator

Definition of the operator	The operator is a person who uses the system or the machine commercially or economically for their own purposes or leaves it to third parties. During operation, the operator bears legal product responsibility for the protection of personnel or third parties.
Obligations of the operator	<ul style="list-style-type: none"> ➔ Comply with the applicable health and safety guidelines and inform your staff accordingly. ➔ Ensure that your personnel are familiar with the regulations on occupational safety and accident prevention. ➔ Provide your personnel with the necessary protective equipment (see <i>chapter 10.3.3 Personal protective equipment</i> [▶ p. 118]). ➔ Prevent assembly by unauthorised and untrained persons. ➔ Only operate the track system under the operating parameters specified in <i>chapter 3 Technical data</i> [▶ p. 32].

10.3.2 Responsibility of the staff

All persons authorised to conduct assembly work on the TRUMPF 95 track system undertake to do so before starting work:

- Follow the basic regulations on occupational safety and accident prevention.
- Read and follow the installation manual including the safety chapter and the safety instructions.

10.3.3 Personal protective equipment

If necessary, the operator must provide the following personal protective equipment for assembly and maintenance personnel:

Symbol	Protective equipment
	Protective gloves
	Safety shoes
	Safety helmet

Tab. 31: Personal protective equipment

10.4 Guidelines and standards

EU/EC directives and standards

The track system complies with the guidelines:

- 2006/42/EC Machinery Directive (MRL)



This manual is based on the Machinery Directive 2006/42/EC that was in force at the time of its preparation.

Please note that this directive will be replaced by EU Regulation 2023/1230, which will be mandatory from 20 January 2027.

The track system complies with the standards:

- DIN EN 17206:2020 Event technology – Machines and other production areas – Safety requirements and tests
- EN 60204-1:2006/A1 Safety of machinery – Electrical equipment of machines – Part 1: General requirements

Harmonised standards

The following harmonised standards are also met:

- DIN EN 60204-1:2019-06 Safety of machinery – Electrical equipment of machines – Part 1: General requirements (IEC 60204-1:2016, modified); German version EN 60204-1:2018
- EN ISO 13849-1:2015 Safety of machinery – Safety-related parts of control systems – Part 1: General principles for design (ISO 13849-1:2015); German version EN ISO 13849-1:2015
- DIN EN ISO 12100:2011-03 Safety of machinery – General principles for design – Risk assessment and risk reduction (ISO 12100:2010); German version EN ISO 12100:2010
- EN 1037:1995 + A1 Safety of machinery – Prevention of unexpected start-up
- EN 62061:2005 Safety of machinery – Functional safety of electrical, electronic, and programmable electronic safety-related control systems

Declaration of Conformity

The TRUMPF 95 track system is a machine within the meaning of the EU Machinery Directive (2006/42/EC) if it is equipped with a motorised drive (drive motor and track switch).



If Gerriets GmbH has been commissioned to install a complete curtain moving system including an electric motorised drive, it will carry out a conformity test on the system.

Depending on the scope, Gerriets GmbH will issue a declaration of conformity or a declaration of incorporation in accordance with the Machinery Directive. If you only purchase the components of the system from Gerriets GmbH to install the system yourself, you are deemed to be the manufacturer within the meaning of the EU Machinery Directive (2006/42/EC). In this case, you are responsible for conducting the conformity testing procedure yourself.

10.5 Disclaimer

Gerriets GmbH accepts no liability or warranty for damage or interference caused by:

- Disregard of the operating manual.
- Non-intended use.
- Use of personnel who are not appropriately qualified.
- Use of spare parts, accessories, and materials that have not been authorised by Gerriets GmbH.
- Changes or set changes to the product not authorised by Gerriets GmbH

11 Abbreviations and explanation

11.1 Terms and explanation

ELL/R	Entertainment load limit at rest in accordance with DIN EN 17206:2020. This characterises the maximum possible load at rest and corresponds to half of the working load limit (WLL).
Nm	Nm (Newton metre) is a unit of measurement for torque, i.e. the force required to revolve (to) an object. It corresponds to a force of one Newton with a lever arm length of one metre.

12 Appendix

12.1 Screw tightening torques

To the torques

The tightening torques are stated in the specific instructions, but if further data is required, please refer to the following table.



Screws subject to high loads must be fastened with lower tightening torques, which is why a screw calculation is necessary. The tightening torques in the handling chapters have priority.

Tightening torque [Nm]			
Screw size	Screw strength class 8.8	Self-locking screw	hand-tight
	According to VDI 2230-1, Table A8	According to the manufacturer	According to DIN 3110
M4	3	—	3
M5	6	11	6
M6	11	19	11
M8	27	42	27
M10	54	85	42
M12	93	130	48
M16	230	330	53
M20	464	—	75

Tab. 32: Overview of screw tightening torques

13 Contact and warranty

13.1 Contact us

Business hours: Monday – Thursday 08:00 – 12:00
13:00 – 17:00

Friday 08:00 – 12:00
13:00 – 15:30

Telephone switchboard: Our switchboard is always available for you during business hours. Outside of business hours, you can leave your messages on our answering machine for an unlimited time or send us your request in the form of an e-mail.

Telephone: Centre / Switchboard +49 7665 – 960 0

Fax: Centre / Switchboard +49 7665 – 960 125

Addresses: Delivery address Gerriets GmbH
Stage equipment
Im Kirchenhürstle 5 – 7
D-79224 Umkirch

Postal address Gerriets GmbH
Stage equipment
PO Box 1154
D-79220 Umkirch

Commercial Register Freiburg HRB No. 2678
VAT number 142191543

Managing Director Hannes Gerriets

Further contact options Internet www.gerriets.com
E-mail info@gerriets.com

Contacts to our locations worldwide & QR code to the website with further international contact options can be found on the back side of the document.

13.2 Customer service and repair

Our product is supplied with a two-year warranty. This covers the replacement or repair of defective parts caused by material or manufacturing faults. The warranty does not cover damage caused by improper use, overload, or improper maintenance.

Please note that modifications or repairs by unauthorised personnel can lead to faults that are not covered by the warranty.

In the event of a defect, please contact our customer service team to check your warranty claim and discuss how we can best help you. With our high quality standards, your complete satisfaction is always our top priority, and we are available to you during our business hours.

Please also see our general terms and conditions at www.gerriets.com.

GERRIETS WORLDWIDE

Gerriets GmbH

HEADQUARTERS
gerriets.com

Gerriets S. A. R. L.

FRANCE
gerriets.fr

Gerriets International Inc.

USA
gerriets.us

Gerriets Great Britain Ltd.

gerriets.co.uk

Gerriets Austria CEE GmbH

gerriets.at

Gerriets Sp. z o.o.

POLAND
gerriets.pl

Gerriets España S. L.

gerriets.es

Gerriets Belgique

Gerriets SARL
gerriets.be

Gerriets Nederland

gerriets.nl

Gerriets Italia

gerriets.it

Gerriets Hellas

gerriets.gr

Gerriets Turkey

gerriets.com/tr

Gerriets Slovenija

gerriets.si

Gerriets Croatia

Gerriets Slovenija
gerriets.hr

Gerriets Hungária

gerriets.hu

Gerriets Bulgaria

gerriets.bg

Gerriets Korea Co. Ltd.

gerriets.com/kr

Gerriets South Africa

gerriets.co.za

Gerriets Brasil

gerriets.com/br

Gerriets

Czech Republic / Slovakia

gerriets.cz

Gerriets Taiwan

gerriets.com

