



Hydra Tattoo Table



Hydra Lift



Hydra Stationary

© Copyright 2024
Earthlite®

All rights reserved. This document or any portion thereof may not be reproduced in any way, including photocopying or translation to another language without the prior written permission from Earthlite.

Earthlite® is a registered trademark of Earthlite, LLC.

Legal Notice

The information provided in this document is intended for informational purposes only and is subject to change without notice. The information provided in this document should not be construed as a commitment by Earthlite®.

Earthlite® assumes no responsibility for the accuracy or suitability of the information contained in this document. This document may contain technical inaccuracies or errors. Earthlite® makes no expressed or implied warranties of any kind concerning the information contained in this document, including, but not limited to, the implied warranties of merchantability and fitness for purpose.

Earthlite® shall not be liable for incidental or consequential damages in connection with or arising out of the product, performance, or use of this document and the information and material it describes.

Introduction

Congratulations on your purchase of the Hydra tattoo table. Blending comfort, durability, and ease-of-use, Hydra tattoo tables provide a luxurious experience for both artist and client

Hydra tables are designed for licensed tattoo professionals and are intended to be used in a professional tattoo studio or other similar commercial environment. While no special training is needed to operate the table, for safety reasons it is important that the instructions contained in this manual are reviewed in detail before the first use. This manual should be read in its entirety by each professional who will be operating the table to ensure the safety of both operator and client. This manual should be saved for future reference.

The Hydra table should not be used in any other manner than described in this manual. Please read, understand, and follow all safety warnings, labels, and instructions. Misuse, use of unnecessary force, or using the product for unintended or unauthorized procedures can result in injury to operator, client, and/or equipment.

Detailed instructions for use and maintenance can be found in this user manual. If you have further questions, please contact us at (800) 872-0560 for US customers, or (760) 599-1112 for international customers. We can also be reached via e-mail at info@earthlite.com.

Table of Contents

Section 1: Safety Information	
Safety Symbols	2
Warnings	2-3
Section 2: Product Overview	
Product Photos	4
Product Specifications	5
Section 3: Installation	
Hydra Stationary Setup/Installation	6-7
Hydra Lift Setup/Installation	8-9
Section 4: Operating Instructions	
Important Safety Notes	10
Electrical Specifications	11
Weight/Lift Capacity	11
Height/Tilt Adjustment	12-13
Section 5: Care & Maintenance	
Care Instructions	14
Troubleshooting	15-16
Warranty Information	17
Contact Us	back cover

SECTION 1: SAFETY INFORMATION

Safety Symbols

Familiarize yourself with the following Safety & Warning symbols. They are designed to prevent damage and injury to you, your clients, and your new Earthlite product.

IMPORTANT: The important safety instructions and warnings in this manual cannot cover all possible problems and conditions that can occur. Use common sense and caution when installing, operating, or maintaining this appliance.



Indicates an imminently hazardous situation which could result in serious or fatal injury.



Indicates a potentially hazardous situation which could result in serious injury.



Indicates a potentially hazardous situation which could result in equipment damage and/or injury.



RISK OF ELECTRIC SHOCK, FIRE, AND EXPLOSION

- 1) Always unplug this furnishing from the electrical outlet before servicing.
- 2) Never use this furnishing if it has a damaged cord or plug, if it is not working properly, if it has been dropped or damaged, or dropped into water. Return the furnishing to a service center for examination and repair.
- 3) Keep the cord away from heated surfaces.
- 4) Do not use outdoors.
- 5) Do not operate where aerosol (spray) projects are being used or where oxygen is being administered.
- 6) To disconnect, turn all controls to the off position, then remove plug from outlet.
- 7) Connect this furnishing to a properly grounded outlet only. See Grounding Instructions.

GROUNDING INSTRUCTIONS:

POWER SUPPLY: (120V AC grounded) Electrical limitations: Do not use extension cord with this product, plug directly into grounded outlet. **This product must be grounded.** If it should malfunction or breakdown, grounding provides a path of least resistance for electric current to reduce the risk of electric shock. This product is equipped with a cord having an equipment-grounding conductor and a grounding plug. This three prong grounded plug will only fit into wall outlet one way. If the plug does not fit fully in the outlet, contact a qualified electrician to install the proper outlet. Do not change the plug in any way.

NORTH AMERICA ONLY

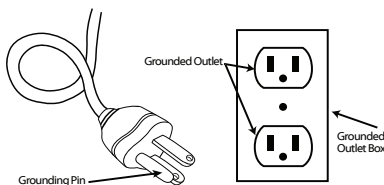

INTERNATIONAL VERSIONS ONLY

This product is for use on a nominal 220V-240V circuit and has a grounding plug (plug type varies by country). Make sure that the product is connected to an outlet having the same configuration as the plug. No adapter should be used with this product.

SECTION 1: SAFETY INFORMATION

WARNING

To reduce the risk of burns, fire, electric shock, or injury to persons:

- 1) Use this furnishing only for its intended use as described in these instructions. Do not use attachments not recommended by the manufacturer.
- 2) Do not operate this equipment unless properly trained.
- 3) Install this furnishing in treatment area not accessible to the public.
- 4) Close supervision is necessary when this furnishing is used by, or near children, invalids, or disabled persons.
- 5) This product does not have “pinch point” protection. Only operate when no possibility of any portion of the body could be caught and injured while moving the table top upward/downward, or activating the back/foot tilt.
- 6) Do not use this furnishing to support video equipment such as televisions or computer monitors.
- 7) Never attempt to use the Head or Leg lift section to support concentrated weight such as sitting or standing

CAUTION

- 1) When lowering any section of the table, make sure that no supplies or any part of yours or your client's body is between the top of your table and its base. This could result in injury, or could damage your table as well as the item. It is recommended that you always return your table top to the lowest flat position to avoid leaving the base exposed.
- 2) When lowering the table height, be sure there are no foreign obstacles underneath your table that could obstruct it from lowering completely. This could damage your table.
- 3) Never set anything under the table frame to avoid collision if lowered.
- 4) Never operate your table on an uneven surface. Adjust the leveling feet so that your table is stable.
- 5) Never raise the head or leg section with a client in the prone position (face down.)
- 6) Never use or store your table in a wet or very humid environment. Water and excessive moisture can damage the wood cabinet and electrical components. Evidence of exposure to water or moisture will void your warranty.
- 7) If you have purchased the Flexible Armrest Option, never use the Armrests as handholds or body support mechanisms, especially when setting clients on or off the table.
- 8) Never drop or insert any object into any opening.

SECTION 2: PRODUCT OVERVIEW

Hydra Stationary

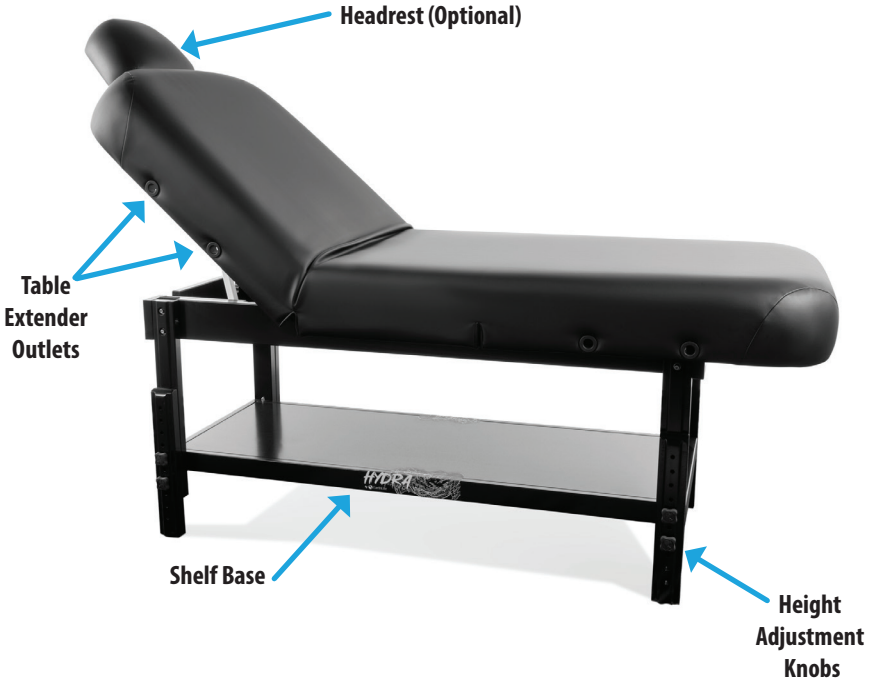

Hydra Lift



SECTION 2: PRODUCT OVERVIEW

Product Specifications

Specification	Hydra Stationary	Hydra Lift
Top Length	73" (185 cm)	73" (185 cm)
Top Width	30" (76 cm)	30" (76 cm)
Height Range	24.5" - 33.25" (62 cm - 84.5 cm)	18" - 37" (46 cm - 94 cm)
Weight Limit	Static weight: 3,200 lbs Max working weight: 800 lbs	600 lbs

**Measurements may vary due to natural material variations.*

Included Features

Feature	Hydra Stationary	Hydra Lift
Frame	Attractive hardwood	Heavy duty steel
Tilt	Manual dual tilt	Manual dual tilt
Height Adjustment	Manual height adjustment	Electric height adjustment with hands-free foot control
Upholstery	Nature's Touch®	Nature's Touch®
Cushioning	Deluxe replaceable 4-layer 4" cushioning system	Deluxe replaceable 4-layer 4" cushioning system
ADA Compliant	No	Yes
Face Cradle	Optional	Optional
Headrest	Optional	Optional
Table extender	Optional	Optional
Tattoo Pillows (3 sizes) 15.5" x 17.5" 15.5" x 20.5" 15.5" x 23.5"	Optional	Optional

SECTION 3: INSTALLATION

Assembling Your Table (Hydra Stationary)



Always use caution when moving your table - always use proper safety procedures/equipment.

Included Hardware



Long Bolt (x8)

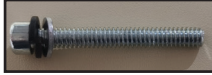

Short Bolt (x8)



Allen Wrench

Instructions:



Step 1 - Lay the base/legs flat on the floor as shown



Step 2 - Place base on its side and swing legs out



Step 3 - Using 2 people, lift by the shelf base and place so legs sit flush against the top as shown above

SECTION 3: INSTALLATION

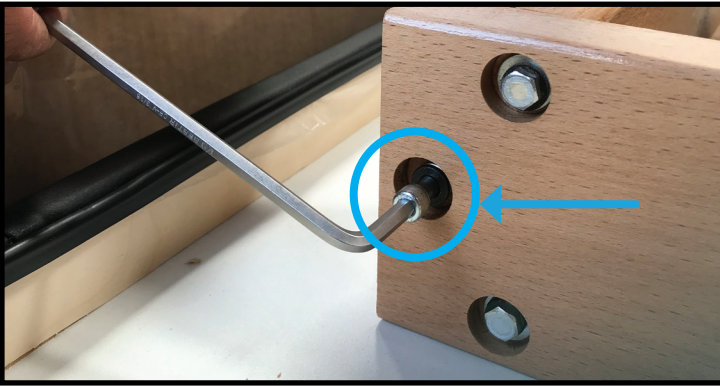

Step 4 - Using allen wrench, secure the long bolts at the head and foot end of the table (1 bolt per leg, 4 total) NOTE: Do not overtighten bolts

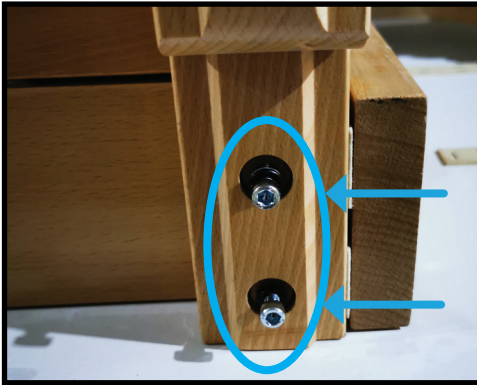

Step 5 - Using allen wrench, secure the short bolts on the sides of the table (2 bolts per leg, 8 total) NOTE: Do not overtighten bolts

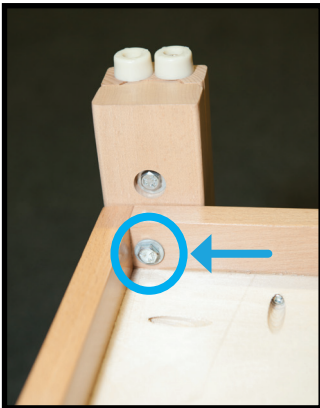

Step 6 - Tighten the bolt shown above on each leg



Step 7 - Tighten the height adjustment knobs on each leg

Step 8 - Tighten the bolts shown in steps 4 and 5

SECTION 3: INSTALLATION

Unpacking Your Table (Hydra Lift)

All Hydra Lift table models come completely assembled and ready to use.

CAUTION

If you did not have your table shipped with 'white glove' service, you may be required to remove your table from its shipping crate. We highly recommend that at least two people conduct the following steps to uncrate the table.

Recommended Tools Needed

Work Gloves



Phillips #1 Screw Driver

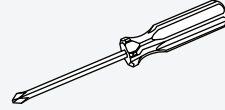

Unpacking your Hydra Lift Table

The following steps will guide you through carefully removing your stationary table from the shipping crate. We recommend wearing work gloves during these steps.

Remove the rectangular cardboard lid from the top of the table. Once you have removed the cardboard lid and surrounding cardboard walls from shipping crate, you will find the wheels and foot glide levelers are seated tightly within wood brackets which have been screwed into the plywood base of the shipping crate.

Step 1

With a Phillips #1 screwdriver (or a powered screwdriver), carefully unscrew and remove the two (2) Front facing wood brackets from the plywood base. **(Diagram A)**

We recommend removing only the two (2) front facing wood brackets **(Diagram A)** that enclose the foot glide levelers. Do not remove the rear brackets which enclose the rear wheels **(Diagram B)**. These brackets are twice as thick as the front brackets, and will be more difficult to remove.

Step 2

Once the front brackets are removed, carefully pull the table straight away from the rear brackets and slide the table onto the floor. We recommend at least two (2) people conduct this step together. **(Diagram C)**

CAUTION

It is possible to lift the table directly out of the shipping crate without removing any of the wood brackets, but this is not recommended because the weight of the table is at least 180 lbs.

Step 3

Once the table is pulled safely away from the shipping crate, make sure the path from the table to your preferred destination is clear of any obstacles or tripping hazards. **(Diagram D)**

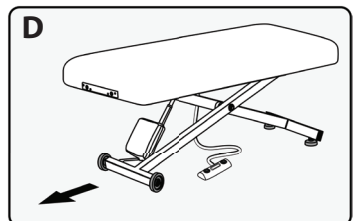
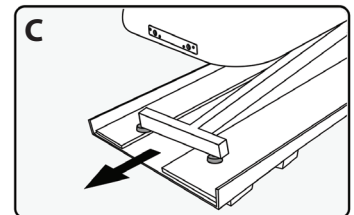
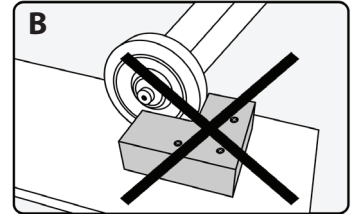
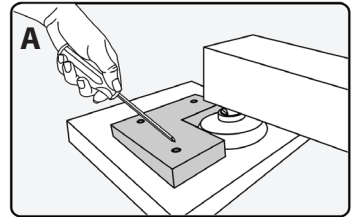

SECTION 3: INSTALLATION

Table Setup (Hydra Lift)

Once your table is placed safely on the floor, temporarily plug the table into a power outlet and using the foot control, raise the table to waist height, which will make it easier for moving. Once the table is at the desired height, unplug the power cable from the outlet and place the power cable along with the foot control on top of the table to prevent a tripping hazard. For ease of movement and flexibility, your table was built with two (2) rear wheels and two (2) front foot glide levers.

The following steps will guide you through safely moving your table to the desired location. We recommend that at least two (2) people conduct the following steps:

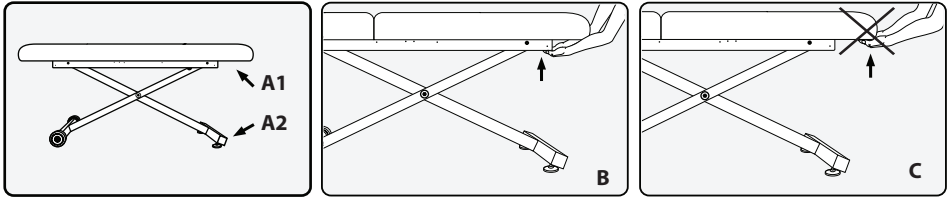

Step 1

Locate the front and rear sections of the table frame underneath the upholstered top as designated by the black arrows above. These are the recommended locations to hold when guiding your table to the desired location (**Diagram A1**).

Note Regarding Step 1:

Locate the front crossbar of the table frame where the foot glide levelers are located (**Diagram A2**). This is a secondary recommended section of the frame to hold if you prefer, but may be more difficult. If you choose this location, properly bend at your knees prior to lifting or pulling the table.

Step 2

Ensure there are no obstacles or tripping hazards in the way and carefully pull the table by the frame into the desired location (**Diagram B**). A second person's assistance is recommended to help push the table from the opposite end.



Do NOT pull or push the table from the upholstered top. Moving the table in this fashion can damage the table and put too much pressure on hinges or other components of the table. Damage made to the table by pulling or pushing on the upholstered top may void the warranty (**Diagram C**).



Install this furnishing in treatment area not accessible to the public.

SAFETY ZONE: The treatment area must have 3-ft minimum unobstructed clearance around entire table. Posting a notice is recommended to maintain "Safety Zone Clearance". The designated work area around the table should be clearly marked off.

Leveling Your Table (Hydra Lift)

Not all commercial and residential floors are perfectly level. The Hydra Lift has foot glide levers that swivel into place against the floor. If your table is not already level when you remove it from the shipping crate, follow these easy steps to level your table:

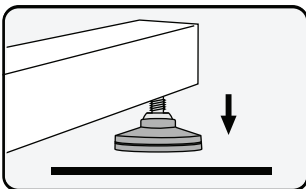

Step 1

Locate which foot glide lever is not even with the floor.

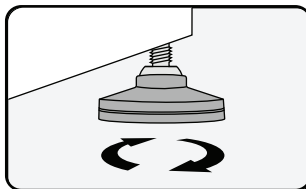

Step 2

Rotate the foot glide lever clockwise or counter clockwise to bring it to ground level.

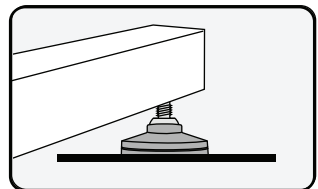

Step 3

Once the foot glide lever is tight with the floor, apply pressure on top of the table to confirm stability.

SECTION 4: OPERATING INSTRUCTIONS

IMPORTANT SAFETY NOTES (Hydra Stationary & Hydra Lift)

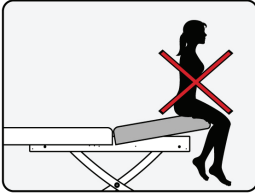

Do not sit or put unnecessary amounts of pressure on the back section of the table when it is in tilt position of any level. This can damage or destroy the tilt mechanism and cause harm or bodily injury to persons. The tilt mechanism is intended solely to be used when a client is properly seated or laying on the table top. Damage caused in this manner may void the warranty.

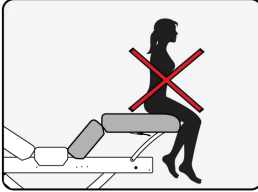

Do not sit or put unnecessary amounts of pressure on the leg section of the table when it is in tilt position of any level. This can damage or destroy the tilt mechanism and cause harm or bodily injury to persons. The tilt mechanism is intended solely to be used when a client is properly seated or laying on the table top. Damage caused in this manner may void the warranty.

SEE BELOW PHOTO FOR Hydra Lift PINCH POINT ZONES, and read the following warnings carefully regarding safe use of your table. The Pinch Point Zones must be kept clear at all times.

NOTE: This table does not have pinch point protection, safety shutoff, or crush sensor.



Always use extreme caution when making any position adjustments to your table. Ensure all body parts and objects are clear from all moving parts and pinch points.







DO NOT store or place anything under the backrest or footrest - this can damage the top and/or tilting mechanism and will void your warranty. This area is not designed for storage or as an area to hold accessories and/or massage supplies while performing any type of service.

DO NOT store or place anything between the frame and the floor - the area underneath the table is not designed for storage or as an area to hold accessories, including foot pedal. This can damage the table, frame, and/or accessories, and will void your warranty.



SECTION 4: OPERATING INSTRUCTIONS

Electrical Specifications (Hydra Lift)

China			
PLUG DESCRIPTION			
NORTH AMERICA	UK / MIDDLE EAST	ASIA	EUROPE
 120V AC	 220V AC	 220V AC	 220V AC

*Other plugs also available for various countries

Spec	North America	Europe
Input Voltage	120 VAC	220 VAC
Input Frequency	60 Hz	50 Hz
Max Amperage	2.5A	1.5A
Max Consumption	287.5 Watts	287.5 Watts

Weight & Lift Capacities (Hydra Lift)

600 lbs.

The Hydra Lift table is powered by a heavy duty lift actuator. The recommended lift capacity is 600 lbs.

50 lbs.

The back and leg sections have a maximum weight capacity of 50 lbs. These sections are not meant to hold full body weight.

Weight & Lift Capacities (Hydra Stationary)

800 lbs.

The Hydra Stationary table max weight capacity is 800 lbs.

50 lbs.

The back and leg sections have a maximum weight capacity of 50 lbs. These sections are not meant to hold full body weight.

SECTION 4: OPERATING INSTRUCTIONS

Height Adjustment (Hydra Stationary)

Note: You will need to either turn your table on its side or have a second person to hold the table in a tilted position while you adjust the legs.



Step 1: Locate the adjustment knobs and turn counterclockwise to loosen.



Step 2: Remove knobs to expose the screws.



Step 3: Remove the outer part of the leg and move up or down to adjust table height. by turning clockwise.



Step 4: When leg is at the desired position, replace knobs and tighten securely

SECTION 4: OPERATING INSTRUCTIONS

Tilt Adjustment (Hydra Stationary & Hydra Lift)

Your Hydra table is equipped with a tilt mechanism which allows you to tilt the back section of the table in 6 increment levels to accommodate your clients.

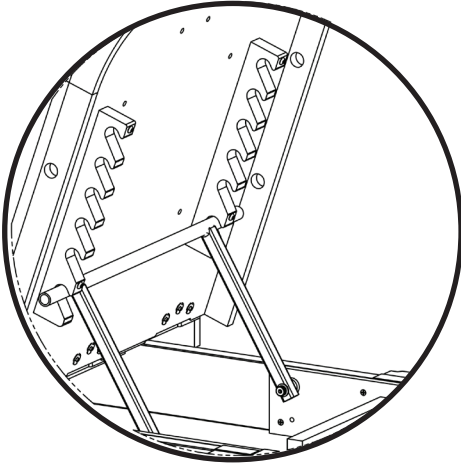

To Tilt the Back Section:

1. With one hand, carefully lift the head end of the table to a little bit higher than the desired level.
2. With the other hand, lift the crossbar and insert the bar into the notch corresponding with the desired height level.
3. Ensure the bar is securely fitted into the notch on both sides, as shown in the image to the left, before taking your hand off of the head end of the table.

Foot Control Operation (Hydra Lift)

Your Hydra Lift foot control is already connected and ready for use. The foot control allows you to simply raise and lower the table, allowing convenient hands-free adjustments.



There is no on/off switch on the foot control, so even while the table is not in use, the foot control is still operable. There is a potential for harm or bodily injury when the foot control is being depressed. We recommend unplugging the table from the power outlet when not in use.



SECTION 5: CARE & MAINTENANCE

Cleaning & Ongoing Maintenance



DO NOT USE acetone, “Armor All” type cleaners, citrus-based cleaners, or industrial cleaners. These can seriously damage the upholstery. Such damage would not be covered under warranty.

With proper maintenance, your table is designed to give you years of trouble-free operation. To ensure your table will continue to function properly and keep its appearance, we recommend the following.

Category	Care Recommendation
Upholstery	Remove day-to-day dirt and smudges with a mild soap and water solution. For tough stains and to disinfect, use a (100 to 1) water to bleach solution. Spray a damp cloth with the solution to clean. After each cleaning, gently wipe the upholstery with a damp cloth and clean water, then allow upholstery to air dry before using or storing. For more difficult stains, please contact your dealer or please call us directly for guidance. For best results, use only the products suggested above.
Steel Table Frame	The powder coated steel frame can be kept clean with a mild detergent and warm water mix. Periodically remove dust from frame with a dry, soft cloth.
Electronic Components	Anti-static electronic aerosol dusters can be used to keep the surfaces of electronic components, power cables, and plugs free of dust.
Lubrication & Mechanical	If necessary, lubricate wheel joints, casters, foot glide levelers, ball joints, and other mechanical parts with a light machine oil. Periodically check table and ensure all bolts remain tightened.
Wood	To maintain the wood finish and retouch scratches, use a high quality furniture wax.

Common lubrication points

For center bolt and shoulder bolt locations (1 & 2), use of a bearing grease, such as GreaseCo Heavy Duty, is recommended.

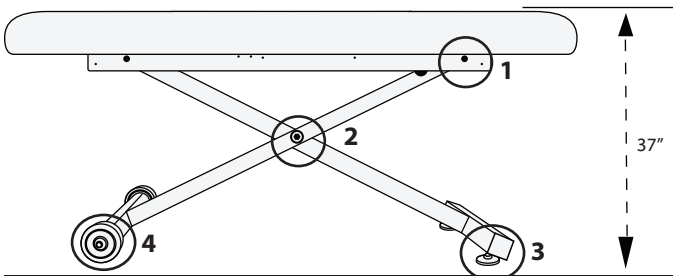

SECTION 5: CARE & MAINTENANCE

Troubleshooting

This helpful troubleshooting guide will provide you with information about how to recognize a problem with your product, determine possible causes, and find a solution.

In the event your specific situation is not covered in this guide, please contact Earthlite so our technical support department can assist you. Beyond the troubleshooting guide below, do not attempt to repair the issue yourself. This can void your warranty.

Unauthorized service will not be covered. Please be sure to contact Earthlite Customer Service first at (800) 872-0560, (760) 599-1112 Int'l.

Issue	Solution
My table is wobbling and moving from side to side.	Hydra Lift - Adjust one or both of the foot glide levers until the table becomes level with the floor and is stable. Hydra Stationary - Ensure legs are all set at the same position and the bolts are tightened securely.
My table is making noise when going up and down. (Hydra Lift)	The center bolt that connects the legs together may be too tight. Remove the plastic cap covering the center bolt and loosen the bolt one half to one full turn.
My table is making a clicking noise and it's not going up or down. (Hydra Lift)	The control box may need to be replaced. Contact Earthlite customer service.
My table is not going up or down and it's not making any sound. (Hydra Lift)	The foot pedal may need to be replaced. Contact Earthlite customer service.
Where can I find my table number?	The table number is located on underside of the table, near head section on a white label. It will read 'SNT' followed by a 6 digit number.

SECTION 5: CARE & MAINTENANCE

Foot Glide Leveler Replacement

If a foot glide leveler becomes damaged or is in need of replacement, carefully follow these next steps.



We recommend at least two (2) people lay the table on its side before conducting step 1 & 5. Lay a towel or blanket down under the table, before resting the table on its side to protect the upholstery.

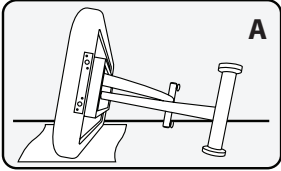

Step 1
Unplug the table and carefully lean the table on its side opposite the foot glide leveler in need of replacement (**Diagram A**).

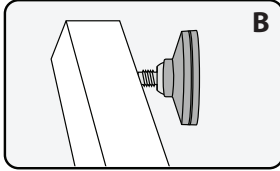

Step 2
Locate the damaged foot glide leveler in need of replacing which is attached to its metal ball joint (**Diagram B**).

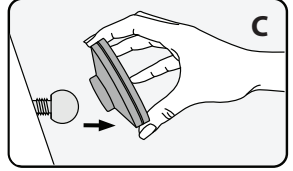

Step 3
Remove the damaged foot glide leveler by pulling it directly off the metal ball joint (**Diagram C**).

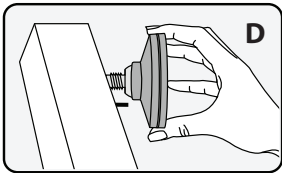

Step 4
Attach the new foot glide leveler to the metal ball joint and push. The Foot glide leveler will snap into place (**Diagram D**).

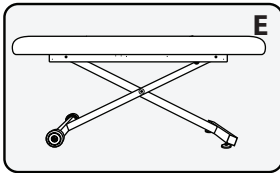

Step 5
Carefully return the table back to its upright position (**Diagram E**).

SECTION 5: CARE & MAINTENANCE

Absolute Satisfaction Return Policy

If you are not completely satisfied with your Earthlite portable table, chair, or accessory, you may return it within thirty (30) days for a full refund (excluding shipping & handling charges on the original order). Standard stationary and lift tables may be returned within thirty (30) days for a refund (excluding shipping & handling charges on the original order) less a 20% restocking fee. Custom or upgraded products are non-returnable and non-refundable. Proof of purchase is required to obtain RMA (Return Material Authorization) and all returns must be in like-new condition and in the original packaging. Customers will be responsible for all shipping charges.

Warranty Information

Earthlite offers an industry best warranty against defects in materials, design, and workmanship, to the original owner, as follows:

- Frame - lifetime warranty
- Foam and upholstery covering - warranted for three (3) years
- Lift motors, controls, electronics - warranted for two (2) years from the original date of purchase*
- Accessories and options - warranted for one (1) year from the original date of purchase

This warranty does not cover damage caused by normal wear and tear, misuse, accidents, or neglect, which includes tears in the upholstery and damage caused by cleaners. All warranties are limited to repair or replacement at Earthlite's discretion, shipping not included. Proof of purchase is required to obtain RMA (Return Material Authorization) and customers may be required to return defective items. International customers are responsible for all associated return costs (inbound and outbound), as well as any applicable duties and taxes.

*If within these two (2) years, there is a defect, malfunction, or failure of the lift motor or controls, Earthlite will replace or repair the defective component at our discretion; shipping not included. Parts are warranted for 90 days after replacement or 2 years from the original date of table purchase, whichever comes later.



EarthLite®

WORLD'S #1 BRAND IN MASSAGE™

Contact Us

Earthlite
990 Joshua Way
Vista, CA. 92081
(800) 872-0560
(760) 599-1112 Int'l
(760) 477-6071 fax
info@earthlite.com

Hours of operation:

Monday - Friday
8:00 a.m. to 5 p.m. PST

Saturday - Sunday
Closed

Visit us online at: earthlite.com



Join us on
Facebook



Follow us
on X



Follow us on
Instagram



Connect with us
on Linked In